



Providing sustainable energy solutions worldwide

Installation- and maintenance instruction

**BG 300**

LME11.230C2E

MB-DLE 407



**-sv**

**1. Manualer på övriga språk**

2. [www.bentone.com](http://www.bentone.com)\  
nedladdning eller scanna  
QR-koden.

3. Skriv in brännarens  
artikelnummer som finns på  
din typskylt (se bild) och välj  
ditt språk.

Detaljerad ecodesign  
information kan laddas ner  
på: [www.bentone.com/  
ecodesign](http://www.bentone.com/ecodesign).

**-fr**

**1. Manuels dans d'autres  
langues**

2. [www.bentone.com](http://www.bentone.com)\  
download ou scannez le  
code QR.

3. Saisir le numéro d'article  
du brûleur sur votre plaque  
signalétique (consultez  
l'illustration) et sélectionnez  
la langue.

Des informations détaillées  
sur l'écodesign peuvent être  
téléchargées à l'adresse:  
[www.bentone.com/  
ecodesign](http://www.bentone.com/ecodesign).



**-en**

**1. Manuals in other  
languages**

2. [www.bentone.com](http://www.bentone.com)\  
download or scan QR-code.

3. Enter the burner`s article  
number on your data plate  
(see picture) and select  
language.

Detailed ecodesign  
information can be  
downloaded at:  
[www.bentone.com/  
ecodesign](http://www.bentone.com/ecodesign).

**-de**

**1. Gebrauchsanweisungen  
in anderen Sprachen**

2. [www.bentone.com](http://www.bentone.com)\  
download oder scannen Sie  
den QR-Code.

3. Geben Sie die  
Artikelnummer des Brenners  
auf Ihrem Typenschild ein,  
(siehe Bild) und wählen Sie  
die Sprache aus.

Detaillierte Informationen  
zum Ecodesign können unter  
[www.bentone.com/ecodesign](http://www.bentone.com/ecodesign)  
heruntergeladen werden.

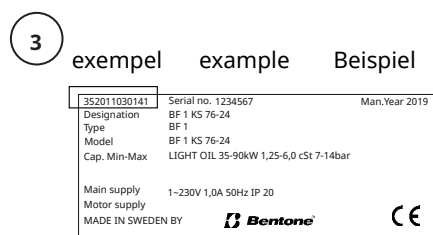

**-da**

**1. Manualer på andre sprog**

2. [www.bentone.com](http://www.bentone.com)\  
download eller scan  
QR-koden.

3. Indtast brænderens  
artikelnummer, der findes  
på typeskiltet (se billede), og  
vælg dit sprog.

Detaljerede oplysninger om  
ecodesign kan downloades  
på: [www.bentone.com/  
ecodesign](http://www.bentone.com/ecodesign).

# Table of contents

<b>1. General Information.....</b>	<b>4</b>	<b>6. Settings .....</b>	<b>20</b>
1.1 Delivery inspection.....	4	6.1 Air adjustment .....	20
1.2 Safety .....	4	6.2 Brake plate adjustment .....	20
1.3 What to do if you smell gas.....	5	6.3 Control of burner head.....	20
<b>2. Technical data.....</b>	<b>6</b>	6.4 Startup.....	21
2.1 Dimensions BG 300 .....	6	6.5 Control of combustion .....	21
2.2 Capacity range .....	7	6.6 Setting the air pressure switch .....	22
2.3 Gas categories, approved gases.....	7	6.7 Setting the gas pressure switch min.....	23
2.4 Technical specification .....	7	<b>7. Gas valve MultiBloc DLE 405 - 412.....</b>	<b>24</b>
2.5 Working field .....	8	<b>8. Service .....</b>	<b>27</b>
2.6 Components.....	9	8.1 Burner Service Schedule, Gas .....	27
2.7 Skeleton diagrams, 1-stage burner .....	10	8.2 Component replacement intervals.....	27
<b>3. Electric equipment.....</b>	<b>11</b>	8.3 Combustion device .....	28
3.1 Safety system .....	11	8.4 Replacement, Damper motor air .....	29
3.2 Wiring diagram.....	11	8.5 Fan .....	30
3.3 Function LME.....	12	8.6 Replacement of electrical components.....	31
<b>4. Installation.....</b>	<b>15</b>	8.7 Vibrations.....	32
4.1 General instructions.....	15	8.8 Control of flame monitoring and ionization current .....	33
4.2 Instructions .....	15	<b>9. Handing over of the installation .....</b>	<b>35</b>
4.3 Inspection and maintenance.....	15	<b>10. Troubleshooting.....</b>	<b>36</b>
4.4 Preparation for assembly .....	15	<b>11. Service- and inspection protocol .....</b>	<b>38</b>
4.5 Gas supply .....	15		
4.6 Electric connection .....	15		
<b>5. Mounting .....</b>	<b>16</b>		
5.1 Gas nozzle.....	17		
5.3 Tightness control .....	18		
5.2 De-aerating.....	18		
5.4 Calculation of gas flow .....	19		

# 1. General Information

The burner may only be used for its intended purpose in accordance with the product's technical data.

We reserve the right to make design changes and cannot be held liable for any misprints or typographical errors.

Modifying the design or using accessories or components that have not been approved by Enertech in writing is strictly prohibited.

This Installation and Maintenance manual:

- is to be regarded as part of the burner and must always be kept near the installation site.
- must be read prior to installation.
- is intended for use by authorised personnel.

## 1.1 Delivery inspection

- Make sure everything is delivered and the goods have not been damaged during transit. Transport damage should be reported to the shipping company.
- If something is wrong with a delivery, report it to the supplier.

## 1.2 Safety

### - before installation:

- Installation and work on the burner and associated system components may only be carried out by persons who have undergone relevant training.
- The product is packaged to prevent damage from occurring when handled – Handle the product with care! Lifting equipment must be used to lift larger packages.
- The products must be transported/stored on a level surface in a dry environment, max. 80% relative humidity, no condensation. Temperature -20 to +60 °C.



### - installation:

- The burner must be installed in accordance with local regulations for fire safety, electrical safety, and fuel distribution.
- The premises must comply with local regulations pertaining to use of the burner and must have adequate air supply.
- The installation site must be free of chemicals.
- Fire extinguisher with Class BE recommended.
- Make sure when installing the burner that there is enough space to service the burner.
- The electrical installation must be professionally carried out in accordance with current mains electricity regulations and in a professional manner.
- Make sure that the burner is suitable for the application (see Technical Data).
- All components must be installed without being bent, twisted or subjected to mechanical or thermal forces that affect components.

- Care must be taken by the installer to ensure that no electrical cables or fuel lines are pinched or otherwise damaged during installation or service.
- Sharp edges can occur on, for example: flame tube, fan wheel and air damper.
- The gas outlet from the pressure regulator must be configured in accordance with applicable regulations and lead to a safe area.

#### **- before first start:**

- The burner must not be put into operation without proper safety and protection devices.
- Permitted ambient temperature during operation -10 to +60 °C. Max. 80% relative humidity, no condensation.
- The surface temperature of the burner's components may exceed 60 °C.
- Handle with caution – the burner has moving parts, and there is risk of crushing injuries.
- Seal inspections must be performed during installation and servicing to prevent leakage.
- Fitting and installation work has been completed and approved.
- Electrical installation has been correctly performed.
- Flue gas ducts and combustion air ducts are not blocked.
- All actuators and control and safety devices are in working order and correctly set.
- If the boiler is equipped with an access hatch, this must be equipped with a hatch opening switch connected to the burner's safety system.
- When in operation, the burner's noise level can exceed 85 dBA – use hearing protection!

#### **- Operation:**

- Carry out all stipulated settings, service and inspection work within the set time.

### **1.3 What to do if you smell gas**

- Turn off the fuel supply.
- Turn off the device and remove the boiler from operation.
- Open windows and doors.
- Prevent open flames or sparking, e.g. do not turn lights on or off, do not use any electrical appliances or mobile phones.
- Evacuate the building.
- Notify the installer or gas supplier of the problem so that it can be rectified.



## 2. Technical data

### The burner is intended for:

- Operation in installations according to EN 303 and EN 676.

### Fuels:

- Natural gas H, E, L, LL.
- LPG, Butane and Propane.

### 2.1 Dimensions BG 300

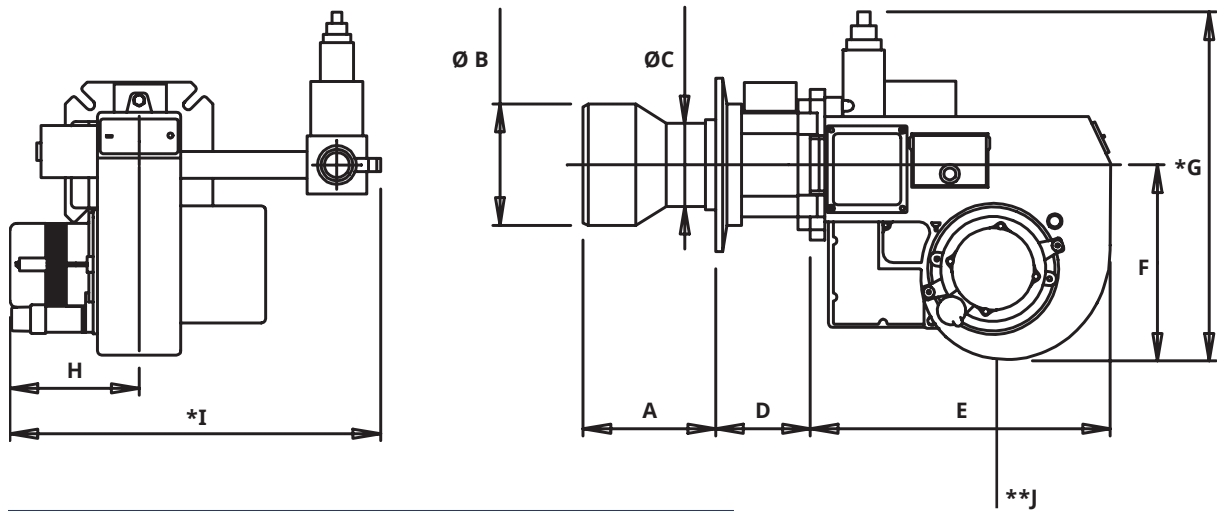

Length of burner tube	Burner tube measure A	Burner tube measure B	Burner tube measure C
145	125	ø120	ø110
245	225	ø120	ø110

D	E	F	G	H	I	J
100	372	220	*475	185	*470	**200

\* The above dimensions are max. measurements. Depending on the components used, the measurements may vary.

\*\* Min. recommended distance to floor.

#### 2.1.1 Measurements for connection to the boiler

K	L	M
12	ø175-240	ø125 (**115)

\*\*\*Dimensions when installing flame tube from the inside of the boiler.

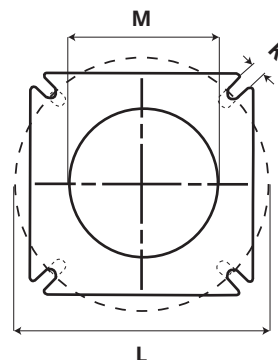

## 2.2 Capacity range

Capacity kW	Gas quantity at min. power Nm <sup>3</sup> /h	Gas quantity at max. power Nm <sup>3</sup> /h	Max. connection pressure mbar	Min connection pressure mbar
<b>BG 300</b>				
G20 50 - 200	5.3	21.2	360	See data plate.
G25 50 - 170	6.2	20.9	360	
G30 65 - 200	2.0	6.2	360	
G31 50 - 200	2.0	8.2	360	

160302-179-2

Gas quantity and capacity vary according to grade of gas and connection pressure.

## 2.3 Gas categories, approved gases

Only dry gas is permitted for use.

Category	Country of destination	Supply pressure
II <sub>2R3R</sub>	AT, BE, BG, CH, CY, CZ, DE, DK, EE, ES, FI, FR, GB, GR, HR, HU, IE, IS, IT, LT, LU, LV, MK, MT, NL, NO, PL, PT, RO, RS, SE, SI, SK, TR	20 mbar
II <sub>2H3B/P</sub>	AT, CH, CY, DK, FI, LT, RO, SE, SK	20 mbar
II <sub>2H3P</sub>	GB, IE	20 mbar
II <sub>2L3B/P</sub>	NL, RO	20 mbar
II <sub>2E3B/P</sub>	PL	20 mbar
I <sub>2E(R)B</sub>	BE	20 mbar
I <sub>3P</sub>	BE	20 mbar

160302-180-3

## 2.4 Technical specification

<b>BG 300</b>	
Main supply <sup>1)</sup>	230V, 1~, 2.1/3.0A, 50Hz, IP20
Max fuse rating	6.3A
NO <sub>x</sub> -class	2 G20, G25 / 3 G30, G31
Noise level	82dBA

<sup>1)</sup> Max operating current, see data plate.

Measurements according to EN 15036-1:2006

Alt.1 The noise level of the burner can be reduced by equipping the burner with silencer. Installation must be done so it does not prevent air supply to the burner.

Alt.2 The burner's noise level can be reduced by connecting the burner's air intake to the air duct that opens into an appropriate location. Installation must be done so it does not prevent air supply to the burner.

## 2.5 Working field

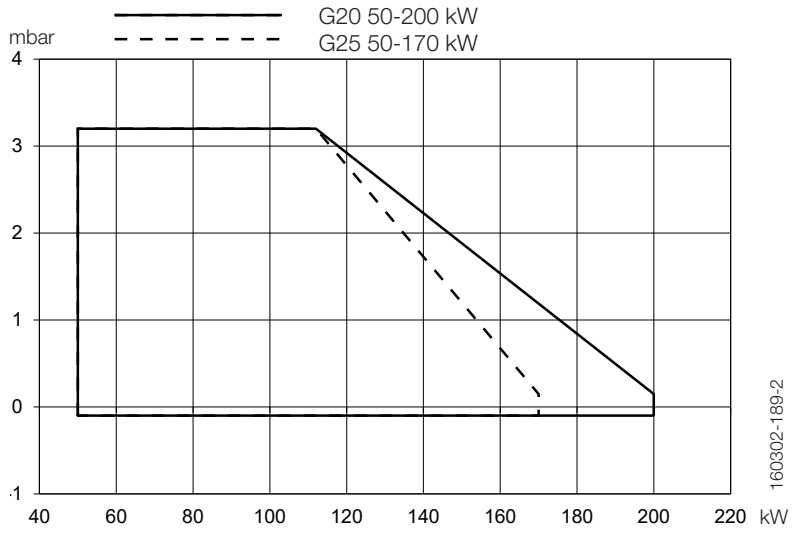

**!** Do not exceed working field.

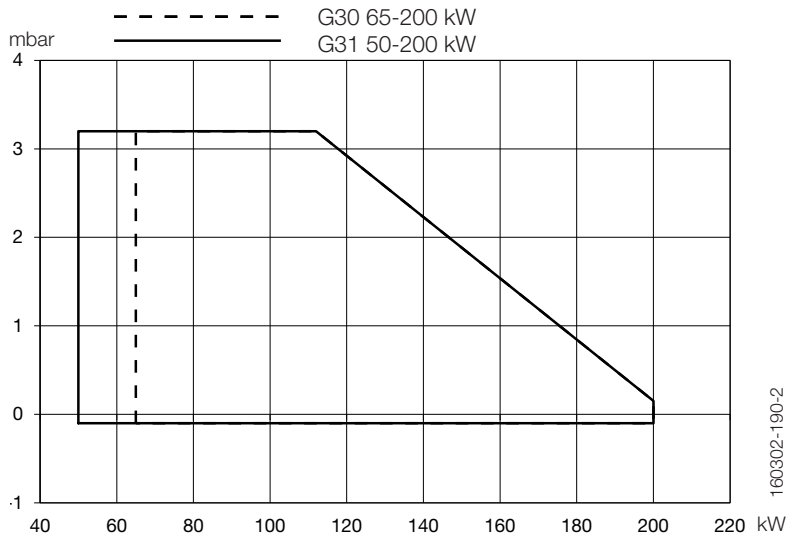



## 2.6 Components

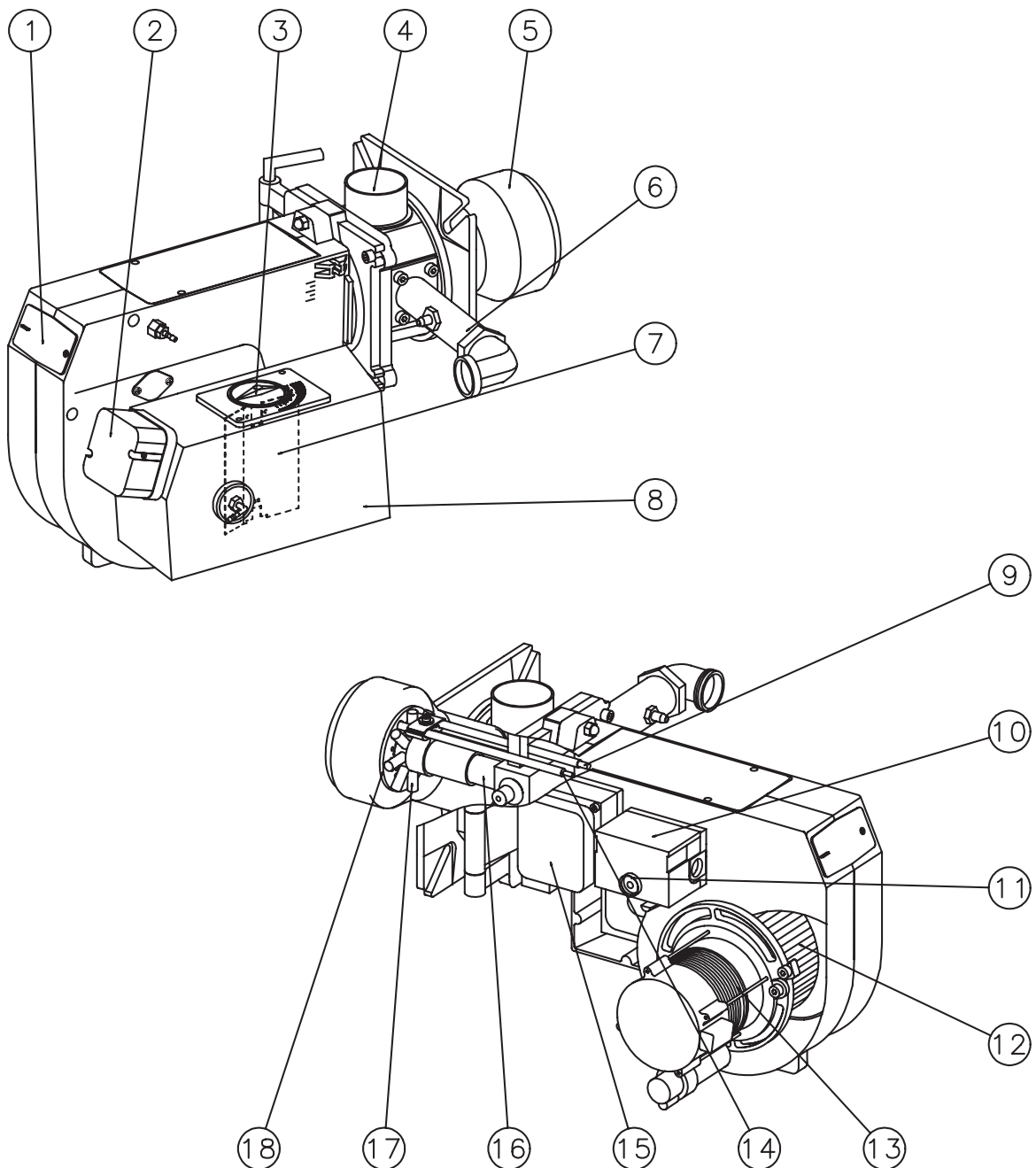

- |                              |                       |                          |
|------------------------------|-----------------------|--------------------------|
| 1. Cover, inspection glass   | 7. Air damper         | 13. Motor                |
| 2. Air pressure switch       | 8. Air intake         | 14. Ionization electrode |
| 3. Air adjustment            | 9. Ignition electrode | 15. Transformer          |
| 4. Inner assembly adjustment | 10. Burner control    | 16. Inner assembly       |
| 5. Flame tube                | 11. Reset button      | 17. Nozzle               |
| 6. Connecting pipe           | 12. Fan wheel         | 18. Brake plate          |

## 2.7 Skeleton diagrams, 1-stage burner

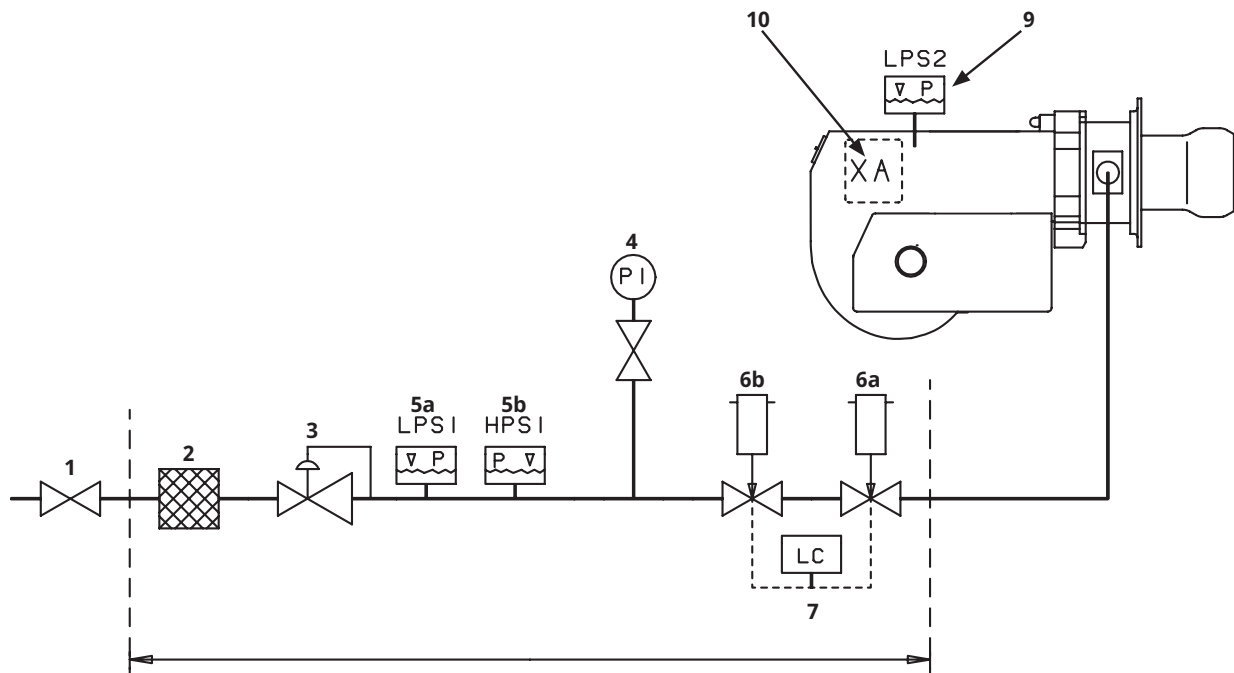

- 1 Ball valve
- 2 Filter
- 3 Pressure regulator
- 4 Pressure gauge with shut-off cock
- 5a Gas pressure switch, Min.
- 5b Gas pressure switch, Max.
- 6a Main valve
- 6b Safety valve
- 7<sup>1)</sup> Leakage control
- 9 Air pressure switch
- 10 Burner control

Pos. 5b, 7: Components not required according to EN 676.

<sup>1)</sup> Required over 1200 kW according to EN 676.

# 3. Electric equipment

## 3.1 Safety system

The safety system (safety switch for hatches, doors, water level, pressure, temperature and other safety devices) must be installed in the safety circuit in accordance with current regulations for the system.

The cables of the safety system must be separated so that the outgoing signal is not placed in the same cable as the incoming signal.

## 3.2 Wiring diagram

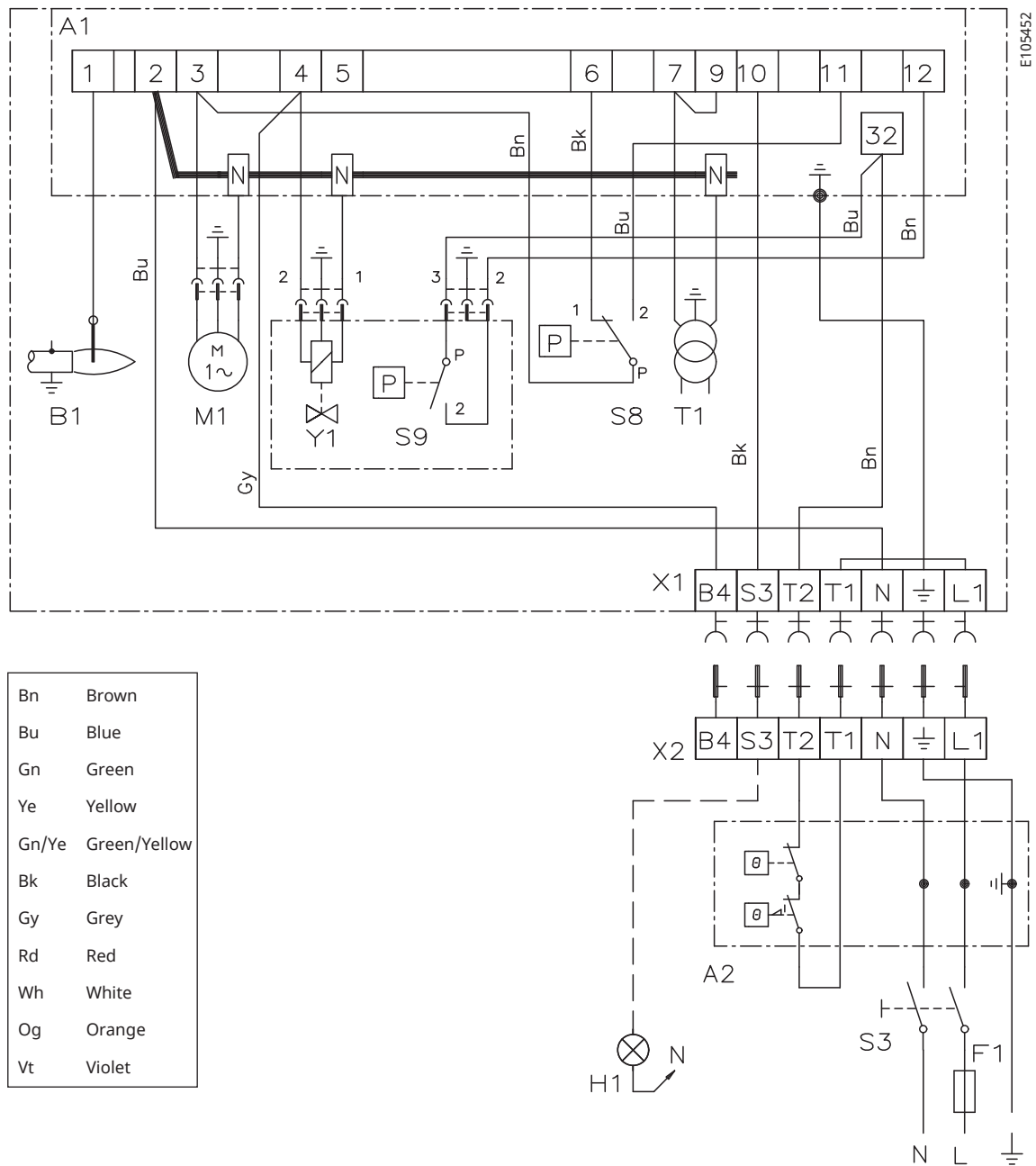

### 3.2.1 Components

A1	Burner control	S8	Air pressure switch
A2	Power control	S9	Gas pressure switch
B1	Ionization electrode	T1	Ignition transformer
F1	Operating fuse	X1	Connection terminal board
H1	Operating lamp	X2	Earth terminal
M1	Motor	Y1	Solenoid valve 1
S3	Control thermostat		

### 3.3 Function LME...

<b>1. Operating switch ON-Thermostat ON-Gas pressure switch ON</b>
A check that the air pressure switch does <u>not</u> indicate fan pressure is carried out.
<b>2. Burner motor starts</b>
A check that the air pressure switch indicates sufficient fan pressure is carried out.
<b>3. The ignition spark is created</b>
<b>4. The gas solenoid valve is open</b>
The gas is ignited. The ionisation electrode now indicates a flame.
<b>5. The safety time expires</b>
The ignition spark ceases. The safety period ceases. If the spark is missing or it disappears after this time limit, the gas burner control is blocked.
<b>6. Operating position</b>
<b>7. Stop</b>
The operation of the burner can now be stopped with the control switch or thermostat.
<b>If the gas burner control is blocked</b>
Red light in the gas burner control is lit. The burner is restarted by pushing the reset button.



Mains connection and fuse in accordance with local regulations.

#### 3.3.1 Technical data

	LME11.230C2E	LME21.230C2
Preignition time	2 s	2 s
Prepurge time	20 s	20 s
Postignition time	2.5 s	2.5 s
Safety lockout time	< 3 s	< 3 s
Reset time after lockout	< 1 s	< 1 s
Reaction time on flame failure	< 1 s	< 1 s
Min. ionisation current at flame	5 µA	5 µA
Max. ionisation current	20 µA	20 µA

160303-301

### 3.3.2 Control program at faults; fault mode indicator LME ....

#### Colour codes

Table colour codes for multi-coloured signal light (LED)		
Status	Colour codes	Colours
Waiting period «tw», other waiting periods	○.....	Off
Ignition phase, ignition controlled	●○○○○●○○●	Blinking yellow
Normal operation	□.....	Green
Operation, poor flame signal	□□○□□□□□	Blinking green
Illegal flame signal during start-up	□▲□▲□▲□▲	Green-Red
Undervoltage	●▲●▲●▲●▲	Yellow-Red
Fault, alarm	▲.....	Red
Blinking code for fault codes	▲○▲○▲○▲○	Blinking red
Interface diagnostics	▲▲▲▲▲▲▲▲	Red flicking

.....	Continuous
○	Off
▲	Red
●	Yellow
□	Green

#### Diagnosing alarm causes

After alarm disconnection, the red alarm signal light is lit continuously.

The diagnosing of the alarm cause can be read according to the following sequence:

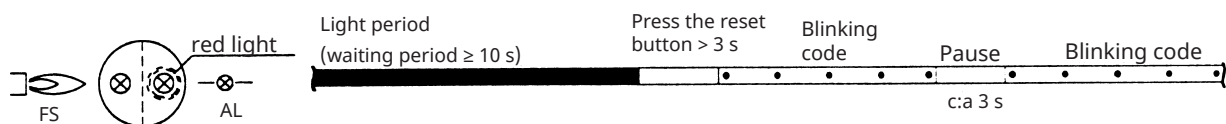

#### Limiting of starting repetitions

LME 11... has a function with start repetition if the flame is not created at start or disappears during operation.. LME 11... allows max. three repetitions during continuous starting cycle.

## Alarm code table

Red blinking code on signal lamp (LED)	Possible causes
Blinking 2 x ..	No flame creation at End of "TSA" - defective or fouled flame monitoring. - defective or fouled fuel valves. - poor burner setting. - defective firing device.
Blinking 3 x ...	"LP" defective - No air pressure switch signal after "t10". - "LP" is welded in open position.
Blinking 4 x ....	Illegal flame signal during start-up.
Blinking 5 x .....	Time out "LP" - "LP" is welded in open position.
Blinking 6 x .....	Free
Blinking 7 x .....	Too many flame disappearances during operation. - poor burner setting. - defective or fouled fuel valves. - defective or fouled flame monitoring.
Blinking 8 x .....	Free
Blinking 9 x .....	Free
Blinking 10 x .....	Connection fault or internal fault, outgoing contacts or other faults.
Blinking 14 x .....	CPI contact not closed.

During the diagnosing of the alarm cause, the control outputs are voltage-free.

- The burner is disconnected.
- Exception, alarm signal «AL» at board 10.
- Reconnection of the burner happens after resetting only.
- Press the reset button 0.5...3 s.

## Interface diagnostics

To change to interface mode, press and hold the reset button longer than 3 s. To go back to the normal position, press and hold the reset button longer than 3 s. If the gas burner control is in the alarm position, it is reset by pressing the reset button 0.5...3 s.

## 4. Installation

### 4.1 General instructions

Installation must be carried out in accordance with current regulations and instructions.

The supplier/installer of the facility is obliged to familiarize himself with all regulations so that the installation meets the requirements of the local authorities.

Installation, assembly and settings must be performed to obtain the best possible function. Only gas intended for the gas burner may be used.

### 4.2 Instructions

It is the installer's responsibility to instruct the user in detail in the functions of the gas burner and the entire system.

### 4.3 Inspection and maintenance

The system must be maintained at the interval specified in the service schedule. If the burner is in a dirty environment, service should be done at more frequent intervals.

### 4.4 Preparation for assembly

Check that the burner's dimensions and capacity range match the current boiler. The power information on the type plate refers to the burner model's min. and max. effect.

### 4.5 Gas supply

In order to obtain good operational safety, it is important that the installation of the gas distribution system is carried out correctly, considering the following:

- Check that the burner is approved for the gas quality of the installation.
- Check that the burner gas components are approved for the specified gas pressure, see type plate.
- Installation must be carried out in accordance with current standards.
- Pipe lines should be assembled so that service can easily be performed on the boiler and burner.
- Pipe lines should be assembled so that any contaminants do not come into contact with the gas components.

### 4.6 Electric connection

- Before work on the electrical connection, the current must be disconnected so that the installation is isolated.
- Connection must be done in accordance with the applicable regulations.
- Connection must conform to the wiring diagram.



If any electrical connection other than that recommended by Enertech is used, there is a risk of property damage and personal injury.

## 5. Mounting

The burner is mounted on the boiler according to the hole pattern on the fixing flange.

1. Remove the gas valve from the burner.
2. Remove fan housing by loosening nut (A), swing out fan housing. Disconnect ionisation and ignition cables from the electrodes. Remove nut (B) on hinged flange and lift fan housing off.
3. Install the fixing flange and the supplied gasket on the boiler. If new mounting holes need to be drilled, use the fixing flange as a template and fasten with M8-M12 screws.
4. Check that the electrodes are correctly set, see chapter Gas nozzle.
5. Mount the fan housing on the fixing flange and fasten with nut (B).
6. Connect the ionisation and ignition cables.
7. Fit the gas valve.
8. Connect the gas with the ball valve provided. Ensure that the pre-screwing, ball valve and tubings are done in such a way that the burner and boiler hatch can be easily used for servicing.
9. Connect the supply cable, operating and safety circuits.



Check for leaks in the gas line.

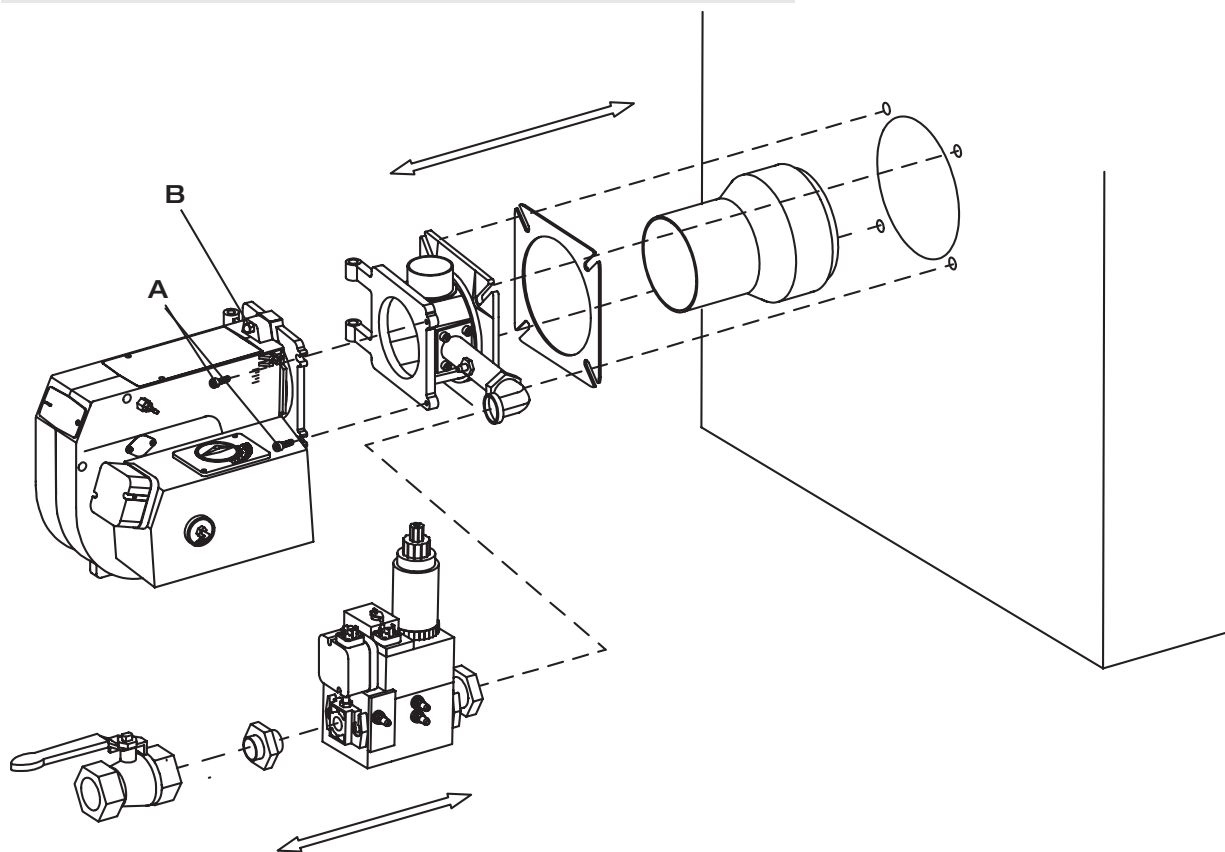



# 5.1 Gas nozzle

Check that the ignition and ionization electrodes are correctly set before mounting on the boiler.

## Propan

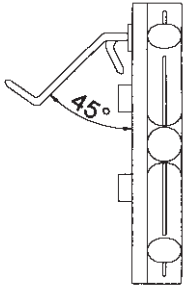

## Natural gas

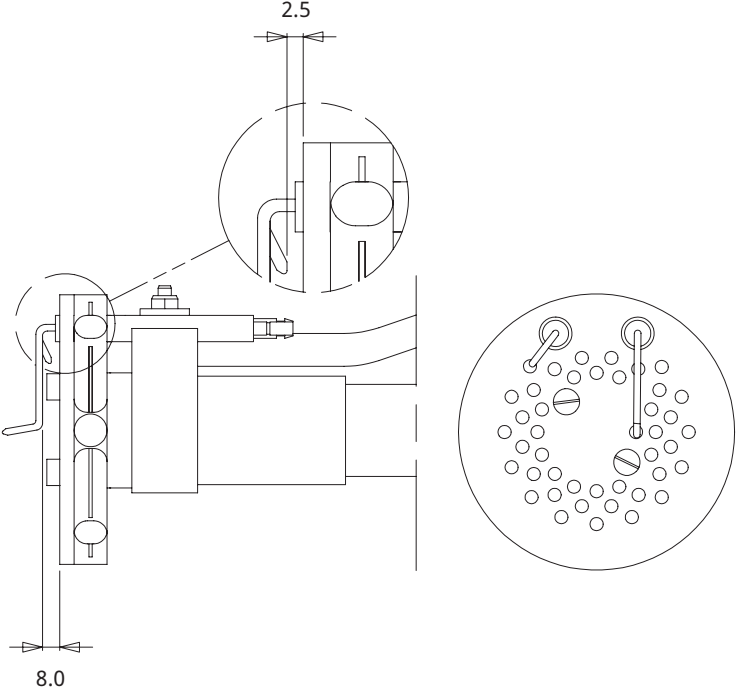

## Biogas (UV detector)

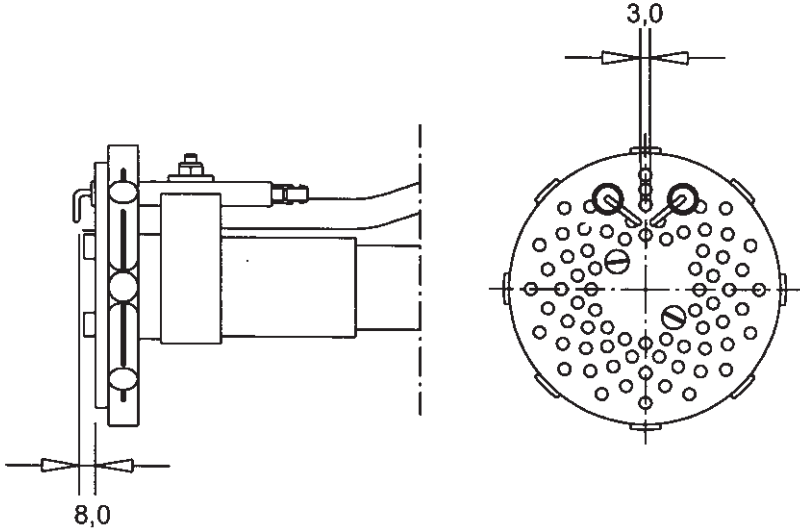

## 5.2 De-aerating

De-aerating the gas line by closing the tap to the gas connection and unscrewing the screw on the measuring nipple for the connection pressure. Connect a plastic hose, open the tap and drain the gas in a safe place. When the de-aerating is completed, be sure to refit the screw on the measuring nipple.

## 5.3 Tightness control

When checking for leakage, the solenoid valve must be closed. A pressure gauge is connected to the measuring nipple "Pa", see picture. The test pressure in the system must not be higher than max. connection pressure, see data plate. If leaks are found during measurement, locate the source using soapy water or leak detection spray. After sealing: check the tightness of the gas fixture again.



Check the gas tightness.

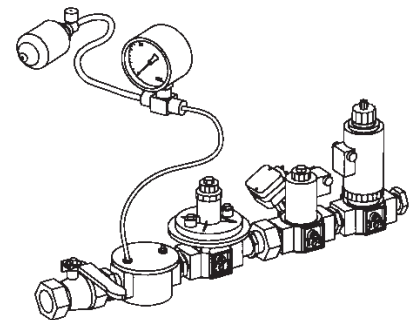
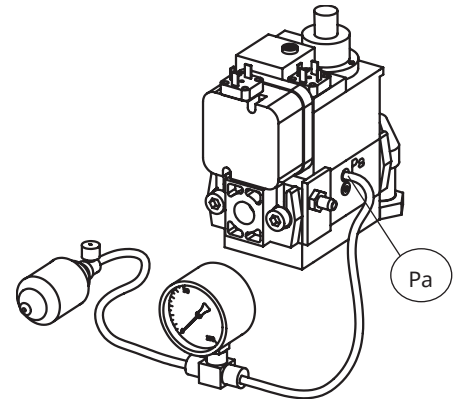

## 5.4 Calculation of gas flow

Formula symbol	Description	Example values
$V_N$	Standard gas volume [Nm <sup>3</sup> /h] Gas volume at normal condition 15 °C 1013 mbar	-
Q	Boiler output [kW]	140 kW
$H_i$	Lower calorific value of gas [kWh/m <sup>3</sup> ] Natural gas under normal conditions 15 °C 1013 mbar, EN 676	9.45 kWh/m <sup>3</sup>
$\eta$	Boiler efficiency (e. g. 90%)	0.9
f	Conversion factor (pressure and temperature compensation)	-
$t_{Gas}$	Gas temperature at gas meter [°C]	15 °C
$P_{Baro}$	Barometric air pressure [mbar]	945 mbar
$P_{Gas}$	Pressure of gas at the gas meter [mbar]	20 mbar
V	Operating volume [m <sup>3</sup> /h]	-
VG	Gas flow measured at the gas meter [m <sup>3</sup> ]	0.46 m <sup>3</sup>
T	Measuring time for consumed gas quantity [s]	91 s

Calculate standard volume using the following formula:

$$V_N = \frac{Q}{\eta \cdot H_i} \quad V_N = \frac{140 \text{ kW}}{0.9 \cdot 9.45 \text{ kWh/m}^3} = 16.5 \text{ m}^3/\text{h}$$

Calculate conversion factor using the following formula:

$$f = \frac{273}{273 + t_{Gas}} \times \frac{P_{Baro} + P_{Gas}}{1013} \quad f = \frac{273}{273 + 15} \cdot \frac{945 + 20}{1013} = 0.90$$

Calculate gas volume using the following formula:

$$V = \frac{V_N}{f} \quad V = \frac{16.5 \text{ m}^3/\text{h}}{0.90} = 18.2 \text{ m}^3/\text{h}$$

Determine operating volume with the following formula:

$$V = \frac{3600 \cdot V_G}{T} \quad V = \frac{3600 \cdot 0.46 \text{ m}^3}{91 \text{ sek}} = 18.2 \text{ m}^3/\text{h}$$

Height above sea level [m]	0	100	200	300	400	500	600	700	800	900	1000	1100	1200
$P_{Baro}$ [mbar]	1013	1001	989	977	966	954	943	932	921	910	899	888	877

### Calorific value of the gas

Gas quality		kWh/Nm <sup>3</sup>	MJ/Nm <sup>3</sup>
Natural gas	G20	9.5	34.02
Natural gas	G25	8.2	29.25

Gas quality		kWh/Nm <sup>3</sup>	MJ/Nm <sup>3</sup>
Butane	G30	32.25	116.09
Propane	G31	24.44	88.00

Lower calorific value  $H_i$  at normal conditions 15 °C and 1013 mbar, EN 676.  
For exact calorific value of the gas, contact the gas distributor.

## 6. Settings

### 6.1 Air adjustment

Loosen the stop screw and turn the knob along the scale to the desired position and tighten the screw. Check the air adjustment by making a flue gas analysis.

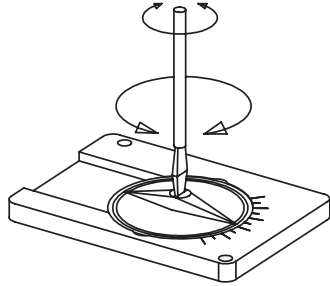

### 6.2 Brake plate adjustment

The position of the brake plate must be adjusted to achieve the most favorable pressure drop across the brake plate.

Loosen the screw on the adjustment device.

- To reduce the opening: turn the knob to the left.
- To increase the opening: turn the knob to the right.

The adjustment of the position of the brake plate affects the air flow. It is therefore always necessary to make a fine adjustment of the air by means of the adjustment device of the burner.

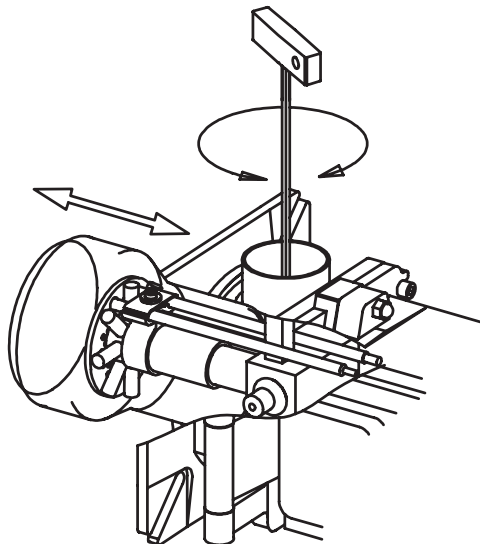

### 6.3 Control of burner head

To check the burner head, brake plate and electrodes, see chapter Service Combustion device.

## 6.4 Startup

After the burner has been mounted on the boiler and the electrical connection, de-aeration and tightness control have been performed, the burner is ready to start-up.

Read the sections dealing with settings of gas valve, damper motor and combustion device before start-up.

Open the ball valve and turn on the main switch, start the burner and begin setting up the system.

## 6.5 Control of combustion

Check combustion using flue gas analysis instruments. Set the burner to about 20% excess air and check that good combustion is obtained. Check the actual gas flow on the gas meter to ensure that the correct input power is achieved.

### Recommended air excess at basic setting

Gas quality	Excess air flue gases		Max % CO <sub>2</sub>
	% O <sub>2</sub>	% CO <sub>2</sub> Lambda 1.2	
Natural gas	3 - 5	≈10	11.9
Propane	3 - 5	≈11.5	13.9
Butane	3 - 5	≈11.5	14.1
Liquefied petroleum gas	3 - 5	≈11	13.8
Biogas	3 - 5		

## 6.6 Setting the air pressure switch

The air pressure switch must block the burner if the amount of air for combustion becomes too low. The air pressure switch must be set so that in the event of a lack of air supply at the burner's max. or min. capacity reacts before the monitored pressure drops so much that poor combustion occurs.

1. Remove protective cover.



Be careful when adjusting the air pressure switch; it contains a live component.

2. Start the burner.
3. Carefully turn the scale on the air pressure switch clockwise until the air pressure switch stops the burner.
4. Measure and note the lowest air pressure in the entire work area.
5. Set the air pressure switch to about 10-15% lower than the lowest noted pressure.
6. Test run the burner and check the function in the entire work area.
7. Refit protective cover.



## 6.7 Setting the gas pressure switch min

The gas pressure switch must react to too low a connection pressure to the burner, prevent the burner from starting and stop the burner during operation. The burner may start again when the connection pressure has risen above the set pressure on the gas pressure switch.

1. Remove protective cover.
2. Open measuring socket and connect a manometer for measuring connection pressure.
3. Start the burner.
4. Measure and note the connection pressure to the burner at the highest input power.
5. Set the gas pressure switch to a value 10-15% lower than the noted pressure.
6. Check the setting by carefully closing the ball valve and at the same time measuring the connection pressure.
7. When the gas pressure switch stops the burner, the measured value must approximately correspond to the setting on the gas pressure switch.
8. Open ball valve.
9. Remove manometer and close measuring socket.
10. Refit protective cover.



Check gas tightness.

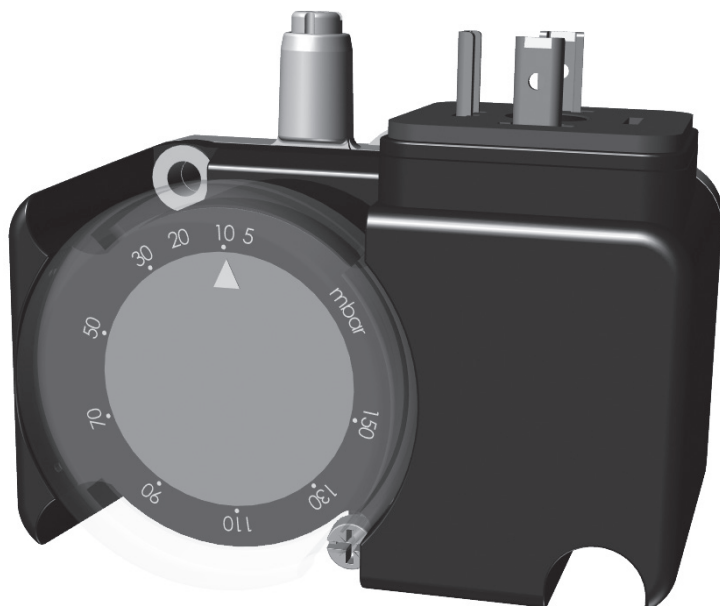

## 7. Gas valve MultiBloc DLE 405 - 412

Max. inlet pressure: 360 mbar.

Adjustable governor pressure: 405 - 412 S50 = 4 - 50 mbar

Solenoid valve:

Slow opening valves with adjustable start load and max. flow.

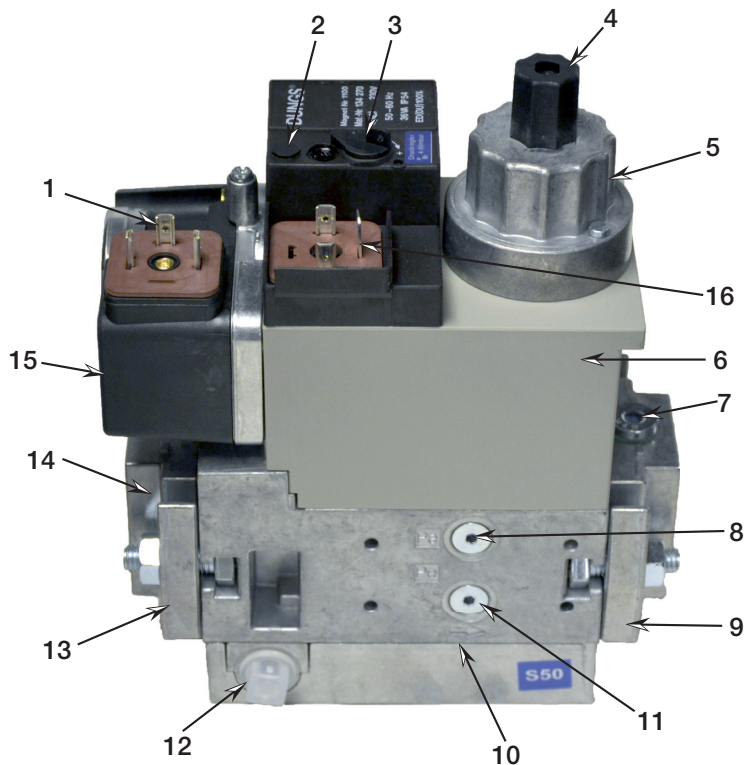

**!** All gasline components shall be assembled and mounted without bending, torque and other mechanical or thermal stress.

1. Electrical connection for pressure switch (DIN EN 175 301-803 connector)
2. Operation display V1, V2 (optional)
3. Lead seal eye, Gouvernor adjustment
4. Setting cap
5. Hydraulic brake / setting plate
6. Solenoid
7. Test point connection G 1/8 possible
8. Test point connection G 1/8 downstream of valve 1, possible on both sides
9. Output flange
10. Gas flow direction
11. Test point connection G 1/8 upstream of V1, possible on both sides
12. Vent nozzle, regulator
13. Filter (below flange)
14. Input flange
15. Pressure switch
16. Electrical connection for valves (DIN EN 175 301-803 connector)



## Flow adjustment

Loosen the fixing screw (a), turn the hydraulic device (b):

- to the right = the gas flow is reduced
- to the left = the gas flow is increased

Do not forget to tighten the fixing screw.

The flow adjustment can also be made by means of the governor. Adjust the outlet pressure to a value giving the desired gas flow on the fully open valve. At small capacities (gas flows) it is also necessary to adjust as above.

## Adjustment of governor

Adjust outlet pressure from governor by means of a screw. Min. and max. outlet pressures corresponds to appr. 60 turns of the spring. It is not possible to change pressure springs in order to change the outlet pressure.

- Turn to the right = the outlet pressure is increased
- Turn to the left = the outlet pressure is reduced

## Adjustment of start gas flow

Remove the protective cover (c).

Turn the adjustment knob (d) (use the protective cover as a tool) to the desired start gas flow.

- Turn to the right = the start gas flow is reduced
- Turn to the left = the start gas flow is increased

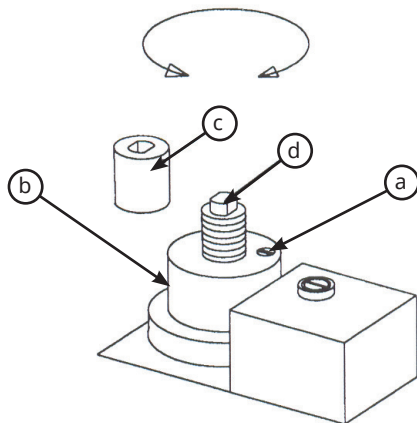

Adjustment of start gas flow

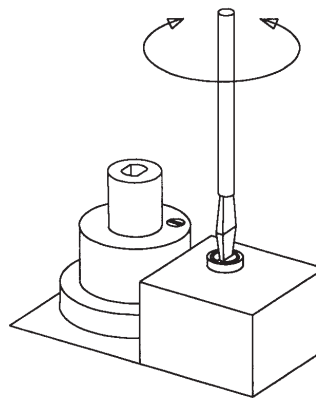

Adjustment of governor

### Pressure taps

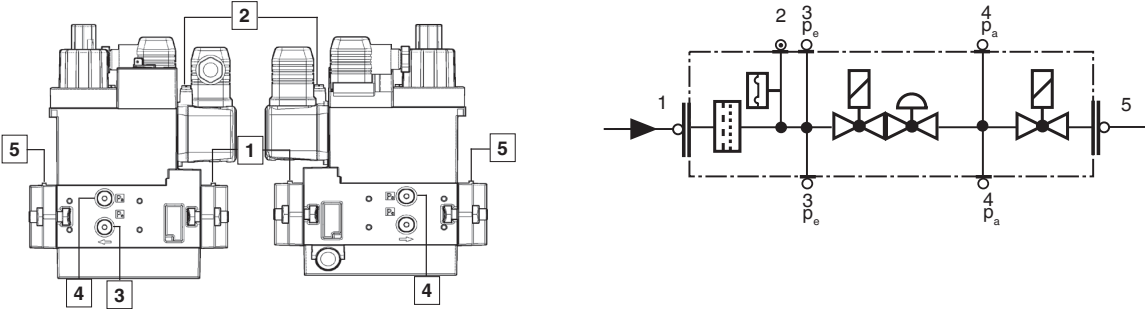

- 1, 3, 4, 5 Screwed sealing plug G 1/8
- 2 Measuring nozzles

### Electrical connection

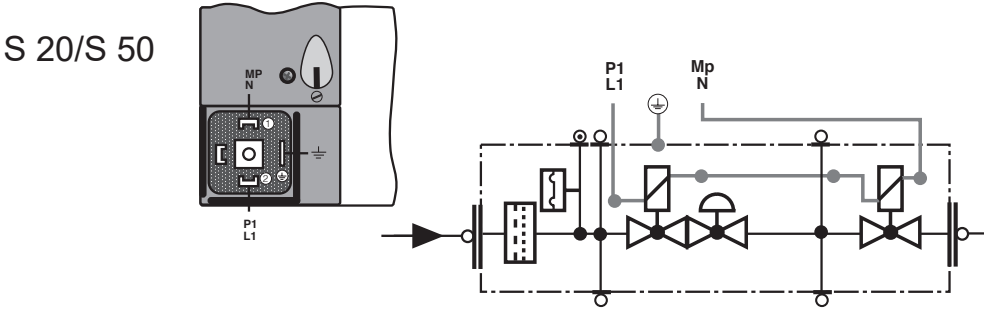

## 8. Service

Service and maintenance work may only be performed by qualified personnel. Perform operational check of all safety systems and components at each service. Only Enertech original parts should be used when replacing components.



Use caution when operating the burner, surfaces may be hot.



### 8.1 Burner Service Schedule, Gas

Servicing must be carried out once a year or after 3,000 hours of operation.

Burner	1 year	3,000 h
Inspection of electrical installation	1 year	3,000 h
Leak check	1 year	3,000 h
Filter	1 year, replacement at $\Delta p > 10$ mbar	3,000 h, replacement at $\Delta p > 10$ mbar
Electrodes	Replacement/cleaning 1 year	Replacement/cleaning 3,000 h
Brake plate	Replacement/cleaning 1 year	Replacement/cleaning 3,000 h
Motor	1 year	3,000 h
Fan wheel	1 Year Replace if need for cleaning/imbalance	3,000 h Replace if need for cleaning/imbalance

### 8.2 Component replacement intervals

Components	Service life - Recommended replacement	Service life - Recommended replacement Operating cycles
Control system	10 years	250,000 starts
Valve control system	10 years	250,000 starts
Pressure switch	10 years	250,000 starts
Ignition system with flame guard	10 years	250,000 starts
UV flame sensor	10,000 h	N/A
Gas pressure controls	15 years	N/A
Gas valve without leak testing	10 years	250,000 starts
Gas valve with leak testing	Replacement upon fault detection	N/A
Gas pressure switch	10 years	250,000 starts
Safety blow-off system	10 years	N/A
Damper motor	N/A	500,000 starts
Contactors	10 years	500,000 starts



The burner and its components must be recycled according to applicable regulations.

## 8.3 Combustion device

1. Disconnect the main power and shut off the fuel supply.



Before obtaining access to electrical and fuel line components all supply circuits must be disconnected.

2. Loosen screws (A) and swing the burner out.
3. Disconnect the ignition and ionisation cables.
4. Check the position of the combustion device. Loosen screw (B) to remove the adjustment device.
5. Loosen screw (C) and remove the combustion device.
6. Check and clean the brake plate and gas inlet, replacing components if necessary.
7. Check the ignition and ionisation electrodes, replace if necessary (see chapter Gas nozzle).
8. Refit the combustion device in reverse order.
9. Press the burner together and lock with screws (A).
10. Turn on the main power and open the fuel supply.
11. Start burner and check/adjust combustion.



Check for leaks in the gas line.

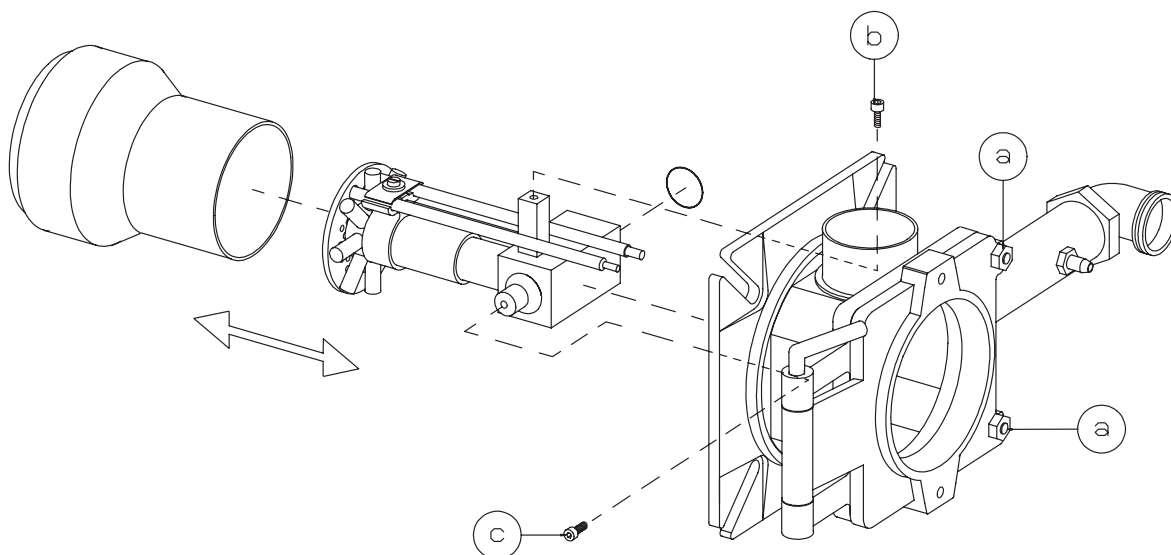

When servicing/replacing components that affect combustion, flue gas analysis and soot test shall be carried out on the installation.

172 615 01-2

## 8.4 Replacement, Damper motor air

1. Disconnect the main power and shut off the fuel supply.



Before obtaining access to electrical and fuel line components all supply circuits must be disconnected.

2. Remove the intake grille at the air intake.
3. Remove the screws (d) holding the damper plate and screw (e) that secures the damper.
4. Turn the damper and then lift up the damper and damper plate.
5. Clean the air damper and air intake, lubricate the damper shaft if necessary.
6. Refit the damper and damper plate.
7. Adjust the damper before tightening the screws (d).
8. Install the intake grille for the air intake.
9. Switch on the main power and open the fuel supply.
10. Start burner and check/adjust combustion.

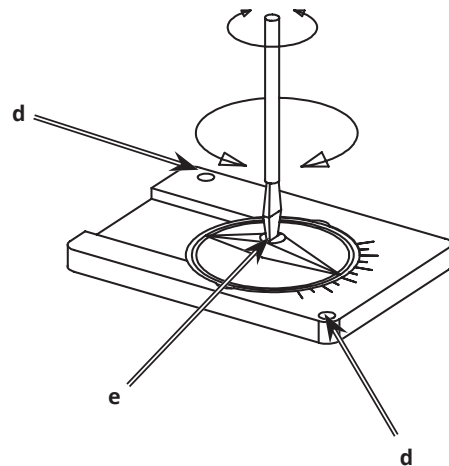

## 8.5 Fan

1. Disconnect the main power and shut off the fuel supply.



Before obtaining access to electrical and fuel line components all supply circuits must be disconnected.

2. Loosen the motor electrical connection and screws (X) enough to turn and lift out the motor.
3. Check the fan wheel attachment and any skew, replace if damaged.
4. Clean or replace the fan wheel.
5. Refit the parts.
6. Switch on the main power and open the fuel supply.
7. Start burner and check/adjust combustion.

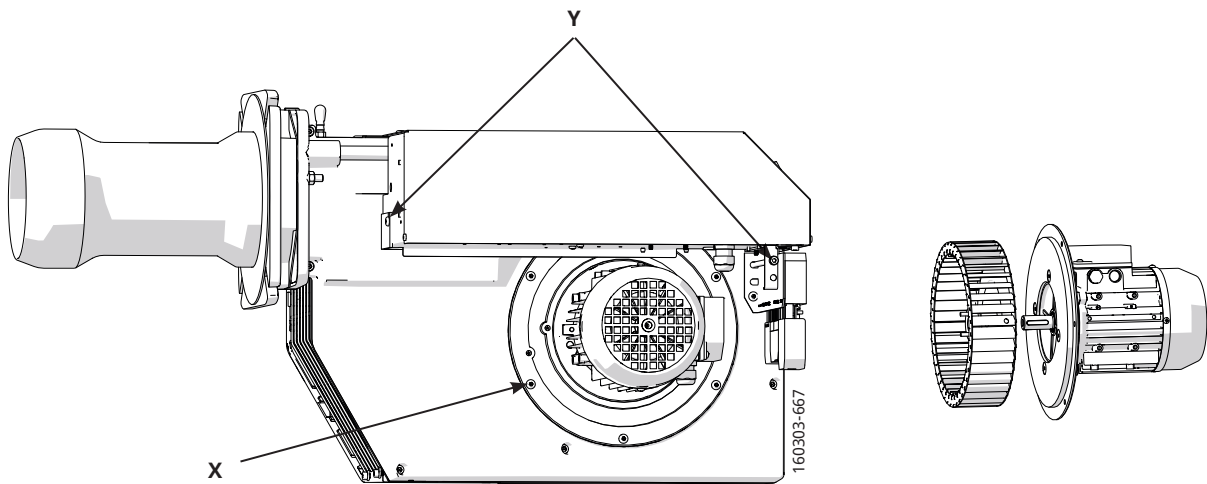

When servicing/replacing components that affect combustion, flue gas analysis and soot test must be carried out following installation.

## 8.6 Replacement of electrical components

1. Disconnect the main power and switch off the fuel supply.



Before obtaining access to terminals, all supply circuits must be disconnected.

2. Note the connection of the existing component and disassemble.
3. Fit new component with same connection or with specified alternative connection.
4. Switch on the main power and check the operation of the new component.
5. Start burner and check/adjust combustion.



When servicing/replacing components that affect combustion, flue gas analysis and soot test must be carried out following installation.

## 8.7 Vibrations

Maximum permitted vibration level is 5.0 mm/s.

- Check tightness of fasteners.
- Check fan wheel for damage and contamination (replace if necessary).
- Check motor shaft and bearings. If they are worn, replace the motor.

Use the screw on the cover to attach the vibration sensor.

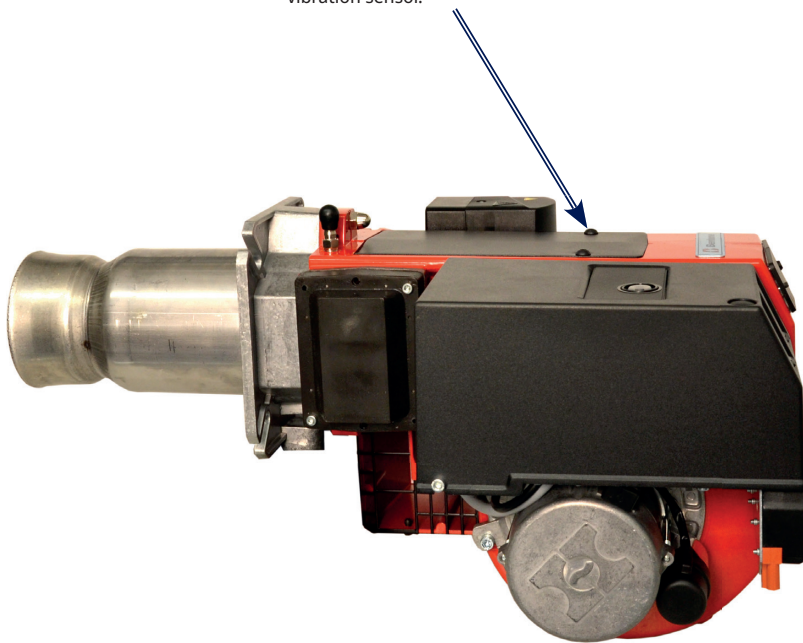



## 8.8 Control of flame monitoring and ionization current

The burner is monitored in the standard version according to the ionization principle. The ionization current must be checked at each service occasion.

The ionization current is measured with a microammeter ( $\mu\text{A}$ ) which is connected in series with the flame electrode and the gas burner control. Connect the  $\mu\text{A}$  meter as shown below. The minimum required ionization current is shown in the table. During normal operation, this current must be significantly higher, preferably more than  $10\ \mu\text{A}$ .

The reason for too low ionization current can be creep current, poor connection to earth, dirt or that the flame electrode may need to be adjusted. The wrong gas/air mix can also cause too low ionization current.

Technical data	
Idle voltage at ION-terminals	AC 115-230V
Short-circuit current	Max. AC 100-300 mA
Min. current for flame detection	Min. DC $1.5\ \mu\text{A}$
Required current to ensure detection	Min. DC $3\ \mu\text{A}$
Possible detection current	Max. DC $20\ \mu\text{A}$
Operational indicator lamp flashes green	$<5\ \mu\text{A DC}$
Operational indicator lamp shines green	$>5\ \mu\text{A DC}$

### 8.8.1 Flame monitoring ionisation

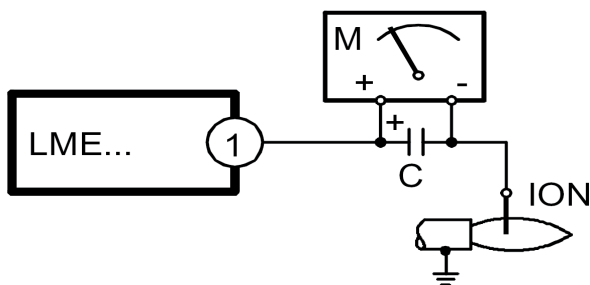

## 8.8.2 UV -detector (QRC)

The UV sensor should not be exposed to temperatures higher than 60 °C. The current passing through the UV sensor when it is lighted must be at least 70  $\mu\text{A}$ . The current can be measured using a rotary coil instrument. A check is necessary only if a malfunction is suspected.

## 8.8.3 Flame monitoring UV-detector (QRC)

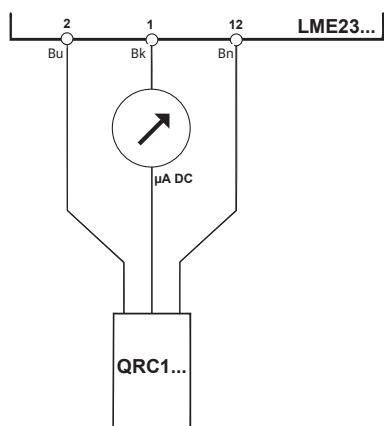

Technical data	
Idle voltage at ION-terminals	AC 115-230V
Short-circuit current	Max. AC 100-300 mA
Max. current for flame detection	Max. DC 5.5 $\mu\text{A}$
Required current to ensure detection	Min. DC 40 $\mu\text{A}$
Possible detection current	Max. DC 60 $\mu\text{A}$
Operational indicator lamp flashes green	<45 $\mu\text{A}$ DC
Operational indicator lamp shines green	>45 $\mu\text{A}$ DC

## 9. Handing over of the installation

- Make repeated start attempts to ensure that the adjustments function.
- Close the ball valve during operation to check that the gas switch switches off at the set value.
- Remove the hose for the air pressure switch to check that the burner locks out.
- Check that all protective covers and measurement nipples are mounted and fastened.
- Fill out necessary test reports.
- Instruct the persons in charge of the operation on the service and maintenance of the installation and what to do should any troubles occur.
- Inspection and service must be carried out by authorized personnel.



Review and service should be performed by authorised personnel only.

## 10. Troubleshooting

Conditions favourable to trouble-free operation of the system can only be guaranteed through the interaction between three factors: electricity, gas flow and combustion air. If any of these factors change, it may cause a malfunction.

Before requesting servicing, check the following points:

1. Are the system's gas taps open?
2. Are the fuses intact and is the power on?
3. Are control devices (room thermostat, boiler thermostat, etc.) correctly set?
4. Is there sufficient gas pressure to the burner?
5. Are the burner controls on standby and not locked?
6. Is there sufficient air supply to the burner?

Cause of fault	Action
<b>Burner does not start:</b>	
No gas.	Make sure all gas taps are open.
No power.	Check the fuse, thermostat and electrical connections.
Burner motor does not start.	Motor protection has tripped. Motor faulty.
Burner control faulty.	Replace.

<b>Burner motor running, no ignition spark at the end of pre-aeration:</b>	
No power in the terminals.	Check the connector. Replace faulty burner controls.
Ignition electrodes in contact with each other or earth.	Adjust.
Ignition electrode porcelain damaged.	Replace the electrodes.
Poor connection to cable connectors.	Adjust connection.
Ignition cables damaged.	Replace.
Transformer damaged, no power to secondary winding.	Replace the transformer.
Ignition cable and ionisation cable swapped around.	Reconnect.

<b>No flame propagation:</b>	
Gas solenoid valve faulty.	Replace.
Gas solenoid valve does not open despite having power.	Replace solenoid valve terminals, or entire valve.
No power to solenoid valve.	Check the connection.
No electrical connection through air pressure gauge.	Check the air pressure gauge's settings and functions.
Ignition load incorrectly set.	Increase/decrease gas supply Reduce airflow.
Burner control faulty	Replace
Air pressure gauge incorrectly set or faulty	Check the settings and reset, or replace
No acknowledgement signal due to incorrect adjustment or misalignment of the control motor cams.	Check the settings and realign.

<b>Burner trips after safety time limit despite flame propagation:</b>	
No ionisation current or UV cell incorrectly positioned.	Adjust ionisation electrode and UV cell Check cables and connectors.
Burner control monitor faulty.	Replace burner control.
Voltage lower than 185V.	Contact an electrician.
Ignition electrodes disrupting ionisation current.	Adjust ignition electrodes. Re-polarise the transformer.
Poor earth connection.	Ensure adequate earth connection.
Phase and neutral swapped around.	Check wiring diagram and change accordingly.

Cause of fault	Action
<b>Burner trips during pre-aeration:</b>	
Air sensor faulty or incorrectly set.	Increase/decrease air setting. Reduce air volume.
Ignition load incorrectly set.	Increase/decrease gas supply Reduce airflow.
Gas pressure too low.	Increase pressure. If necessary, contact gas supplier.

<b>Pulsations at start-up:</b>	
Ignition electrodes incorrectly set.	Adjust .
Gas pressure too high.	Check and adjust using pressure gauge and pressure control valve.
Flue gas side blocked.	Check the chimney flue.

<b>Burner pulsates during operation:</b>	
Burner incorrectly set.	Adjust.
Burner dirty.	Clean the burner.
Incorrect chimney.	Check and modify dimensions if necessary.

<b>Burner functioning properly but with occasional blockage:</b>	
Ionisation current too low.	Check. Must be at least 6µA, but should ideally lie between 8-20µA.
UV cell incorrectly positioned.	Adjust.
Voltage drop at certain times.	Must not drop below 15% of rated voltage. Contact an electrician if necessary.
Incorrectly set or faulty air sensor.	Check the settings and reset, or replace.
Ignition electrode overload.	Replace.
Burner control ambient temperature too high.	Insulate for heat, Max. 60 °C.
Ignition spark too weak.	Check the transformer.

<b>Poor combustion:</b>	
Poor draught conditions.	Check the chimney.
Flue gas temperature too high.	Boiler overloaded Decrease the gas volume, sweep the chimney if necessary.
CO2 content too low.	Choke the air supply. Check the boiler for any leakages. Choke the draught if too high.

<b>CO content too high:</b>	
Surplus air when using natural gas and liquefied petroleum (propane, butane).	Choke the air supply.
Poor air supply.	Open the air supply. Check flue gas damper.
Holes in gas nozzle clogged.	Clean.
Poor fresh air intake.	Check and increase.
Flame at incorrect angle due to combustion head out of position.	Check the combustion head and readjust.

<b>Condensation build up in boiler and chimney:</b>	
Flue gas temperature too low or gas volume too low.	Raise the flue gas temperature by increasing gas volume Insulate the chimney.

# 11. Service- and inspection protocol

<b>Installation</b>		<b>Boiler</b>		
<b>Name:</b>		<b>Type:</b>		<b>Efficiency kW:</b>
<b>Address:</b>		<b>Burner</b>		
		<b>Type:</b>		<b>Efficiency kW:</b>
<b>Installed by:</b>		<b>Date:</b>		

Date	Nm <sup>3</sup> gas/h	Governor		CO <sub>2</sub>	CO	Fluegas temp	Ionisation current	Pressure		Efficiency
		Before	After					Fire room	Chimney	
Measurement				%	%	°C	µ A	mbar	mbar	%
	Small Flame									
	Large Flame									
	Measures									

Date	Nm <sup>3</sup> gas/h	Governor		CO <sub>2</sub>	CO	Fluegas temp	Ionisation current	Pressure		Efficiency
		Before	After					Fire room	Chimney	
Measurement				%	%	°C	µ A	mbar	mbar	%
	Small Flame									
	Large Flame									
	Measures									

Date	Nm <sup>3</sup> gas/h	Governor		CO <sub>2</sub>	CO	Fluegas temp	Ionisation current	Pressure		Efficiency
		Before	After					Fire room	Chimney	
Measurement				%	%	°C	µ A	mbar	mbar	%
	Small Flame									
	Large Flame									
	Measures									



# EU Declaration of conformity

## Bentone Gas Burners

Type:	Certificate No.	Type:	Certificate No.
BFG 1	CE-0123CT1269	BG 550	CE-0123CT1326
STG 120	CE-0123CT1270	BG 650	CE-0123CT1348
STG 146	CE-0123CT1281	BG 700	CE-0123CT1359
BG 300	CE-0123CT1292	BG 800	CE-0123CT1360
BG 400	CE-0123CT1304	BG 950	CE-0123CT1371
BG 450	CE-0123CT1315		

This declaration of conformity is issued under the sole responsibility of the manufacturer.  
The object of the declaration described above is in conformity with:

- **Gas Appliance Regulation 2016/426/EU**
- **Machinery Directive 2006/42/EC**
- **EMC 2014/30/EU**
- **The Restriction of the Use of Certain Hazardous Substances (RoHS) Directive 2011/65/EU**

References to the relevant harmonised standards used or references to the other technical specifications in relation to which conformity is declared:

**EN 676:2020** Excluding the requirements of Annex J/K.  
Automatic forced draught burners for gaseous fuels.

**Additional information can be downloaded at: [www.bentone.com](http://www.bentone.com)**

Manufacturer: Enertech AB  
Näsvägen 8  
SE-341 34 LJUNGBY  
Sweden

Notified Body: TUV SÜD Product Service GmbH  
Ridlerstraße 65  
D-80339 München, Germany  
Notified Body Number: 0123

Ljungby, 2022-10-10

Joachim Hultqvist

Technical Manager  
Enertech AB

Ola Karlsson

Quality Manager  
Enertech AB

# UK Declaration of conformity

## Bentone Gas Burners

Type:

<b>BFG 1</b>	<b>BG 300</b>	<b>BG 550</b>	<b>BG 800</b>
<b>STG 120</b>	<b>BG 400</b>	<b>BG 650</b>	<b>BG 950</b>
<b>STG 146</b>	<b>BG 450</b>	<b>BG 700</b>	

This declaration of conformity is issued under the sole responsibility of the manufacturer.  
The object of the declaration described above is in conformity with:

- **Gas Appliances (Enforcement) and Miscellaneous Amendment Regulations 2018**
- **Supply of Machinery (Safety) Regulations 2008**
- **Electromagnetic Compatibility Regulations 2016**
- **The Restriction of the Use of Certain Hazardous Substances in Electrical and Electronic Equipment Regulations 2012**

References to the relevant harmonised standards used or references to the other technical specifications in relation to which conformity is declared:

**BS EN 676:2020** Excluding the requirements of Annex J/K.  
Automatic forced draught burners for gaseous fuels.

**Additional information can be downloaded at: [www.bentone.com](http://www.bentone.com)**

Manufacturer: Enertech AB  
Näsvägen 8  
SE-341 34 LJUNGBY  
Sweden

Approved Body: TUV SÜD BAPT Unlimited  
Octagon House,  
Concorde Way, Segensworth North,  
Fareham, Hampshire,  
PO 15 5RL, United Kingdom  
Approved Body Number: 0168

Ljungby, 2022-10-10

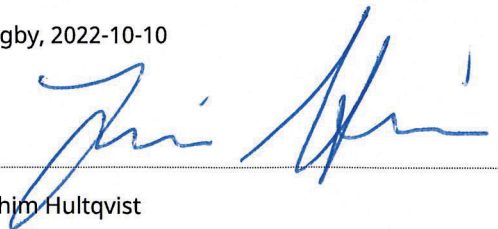

Joachim Hultqvist

Technical Manager  
Enertech AB



Ola Karlsson

Quality Manager  
Enertech AB









