



Providing sustainable energy solutions worldwide

Installation- and maintenance instruction
BG 400 M



Table of contents

1. General Information	4
2. Technical data	7
2.1 Burners are intended for use at:	7
2.2 Dimensions	7
2.3 Description BG 400	10
3. General instructions	11
3.1 General instructions	11
3.2 Installation and maintenance instructions	11
3.3 Instructions	11
3.4 Inspection and maintenance	11
3.5 Start up	11
3.6 Commissioning of installation	11
4. Installation	12
4.1 Delivery check	12
4.2 Preparations for installation	12
4.3 Gas supply	12
4.4 Electric connection	12
4.5 Skeleton diagrams	13
4.6 Mounting on the boiler	14
4.7 Inspection of gas nozzle before commissioning	15
4.8 Gas nozzle	16
4.9 Setting Air damper	17
4.10 Damper motor, air volume	17
4.11 Adjustment of gas flow	17
5. Setting the burner	18
5.1 Adjustment of brake plate	18
5.2 Control of burner head	18
5.3 Setting the air pressure switch	20
5.4 Setting the min. gas pressure switch	21
5.5 Multibloc MB-VEF B01, 407-412	22
5.6 Recommended excess air when using default setting	25
5.7 Determining the gas quantity for the system	25
5.8 Calculating the quantity of gas supplied	27
6. Service	28
6.1 Servicing the combustion assembly	28
6.2 Replacement of damper motor, air	29
6.3 Flame monitoring and ionisation current check	30
6.4 UV-Detector	31
7. Handing over of the installation	32
8. Fault location, functional troubles	32
9. Electric equipment	33
9.1 Safety system	33
9.2 Wiring diagram LME	34
9.3 List of components	35
9.4 Control program at faults; fault mode indicator LME	37
10. Troubleshooting	38
11. EU Declaration of conformity	41
13. General instructions for gasburners	42

1. General Information

This Installation and Maintenance manual:

- is to be regarded as part of the burner and must always be kept near the installation site
- is intended for use by authorised personnel
- must be read prior to installation
- must be observed by all who work with the burner and associated system components
- work with the burner may only be carried out by certified installers/ personnel

Enertech AB is not liable for any typographical errors and reserves the right to make design changes without prior notice.

Safety instructions

- The burner may only be used for its intended purpose in accordance with the product's technical data.
- The burner may only be installed and operated by authorised personnel.
- The product is packaged to prevent damage from occurring during handling. Handle the product with care. Lifting equipment must be used to lift larger packages.
- The products must be transported/stored on a level surface in a dry environment, max. 80% relative humidity, no condensation. Temperature -20 to +60 °C.
- Check that the burner is compatible with the boiler's output range.
- All components must be installed without being bent, twisted or subjected to mechanical or thermal forces which can affect the components.
- The burner must be installed so that it complies with local regulations for fire safety, electrical safety, and fuel distribution.
- The gas outlet from the pressure regulator shall be configured in accordance with applicable regulations and lead to a safe area.
- Make sure when installing the equipment that there is enough space to service the burner.
- Permitted temperature during operation -10 to +60 °C. Max 80% relative humidity, no condensation.
- The installer must ensure that the room has adequate air supply.
- The room must comply with local regulations pertaining to its intended use.
- The installation site must be free of chemicals.
- Burner pipes, fan wheels and air dampers may contain sharp edges.
- The surface temperature of the burner's components can exceed 60 °C.
- Caution: The burner has moving parts, and there is risk of crushing injuries.



- The electrical installation must be professionally carried out in accordance with applicable high voltage regulations, as per Enertech's recommendations.
- Before servicing, shut off the fuel supply and turn off the power to the burner.
- Seal inspections must be performed during installation and servicing to prevent gas leakage.
- Care should be taken by the installer to ensure that no electrical cables or fuel lines are crushed or otherwise damaged during installation or servicing.
- If the boiler is equipped with an access hatch, this must be equipped with a hatch opening switch connected to the burner's safety system.
- When in operation, the burner's noise level can exceed 85 dBA. Use hearing protection.
- The burner must not be put into operation without proper safety and protection devices.
- A Class BE fire extinguisher is recommended.
- It is forbidden to alter the design or use accessories which have not been approved by Enertech in writing.
- Prior to operation, the following points must be checked:
 - fitting and installation work has been completed and approved
 - electrical installation has been correctly performed
 - flue gas ducts and combustion air ducts are not blocked
 - all actuators and control and safety devices are in working order and correctly set



Actions to take if you smell gas

Turn off the equipment and the boiler. Open windows and doors. Prevent open flames or sparking, e.g. do not turn lights on or off, do not use any electrical appliances, do not use mobile phones. Open windows and doors. Close the gas ball valve. Warn residents; do not use doorbells. Evacuate the building. Notify the installer or gas supplier once the building has been evacuated.

Burner servicing schedule

Servicing must be carried out once a year or after 3000 hours of operation

Burner	1 year	3000 hrs
Inspection of electrical installation	1 year	3000 hrs
Leakage check	1 year	3000 hrs
Filter	1 year replacement at $\Delta p > 10$ mbar	3000 hrs replacement at $\Delta p > 10$ mbar
Electrodes	Replacement/Cleaning 1 year	Replacement/Cleaning 3000 hrs
Brake disc	Replacement/Cleaning 1 year	Replacement/Cleaning 3000 hrs
Motor	1 year	3000 hrs
Fan wheel	1 Year Replacement when cleaning needed/ imbalance	3000 h Replacement when cleaning needed/ imbalance

Component replacement intervals

Control system	10 years	250,000 starts
Valve control system	10 years	250,000 starts
Pressure switch	10 years	250,000 starts
Ignition system with flame guard	10 years	250,000 starts
UV flame sensor	10000 hrs	N/A
Gas pressure regulators	15 years	N/A
Gas valve without seal testing	10 years	250,000 starts
Gas valve with seal testing	Replacement upon fault detection	N/A
Gas pressure switch	10 years	250,000 starts
Safety blow-off system	10 years	N/A
Damper motor	N/A	500,000 starts
Contactors	10 years	500,000 starts



The burner and its components must be recycled according to applicable regulations.

Delivery check

- Make sure everything is delivered and the goods have not been damaged during transit.
- If something is wrong with a delivery, report it to the supplier.
- Transport damage must be reported to the shipping company.

2. Technical data

2.1 Burners are intended for use at:

- Hot water boilers in intermittent operation

2.2 Dimensions

- Gas connection 3/4-2"

Dimensions stated in mm

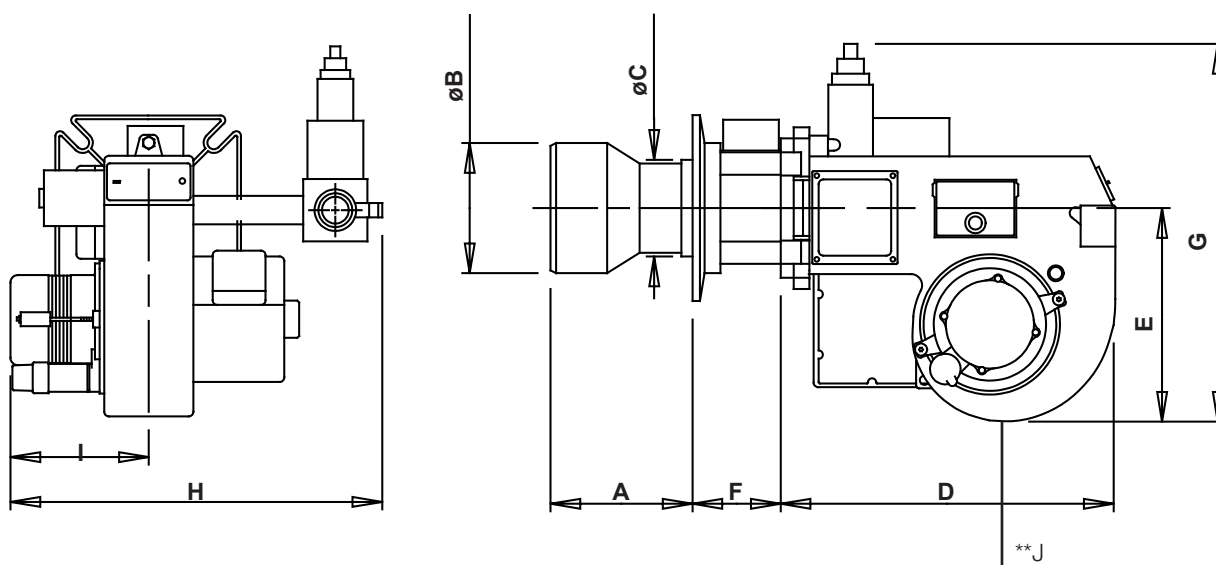

Type		Length of burner tube	Flange measure A	Burner tube measure B	Burner tube measure C
BG 400	Standard 1	172	155	ø140	ø110
	Standard 2	272	255	ø140	ø110

	D	E	F	G	H	I	J
BG 400	410	250	100	*410	*506	192	**200

2.2.1 Heat generator connection dimensions

	K	L	M
BG 400	M10	ø 175-240	ø145(**115)

* The above dimensions are max. measurements. Depending on the components used, the measurements may vary.

** Min. recommended distance to floor.

***Dimensions when installing blast tubes from the inside of the boiler

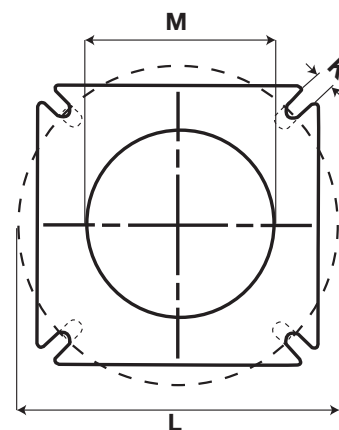

172 515 61 2018-02-03

2.2.2 Capacity range

Capacity kW	Gas quantity at min. power Nm ³ /h ¹⁾	Gas quantity at max. power Nm ³ /h ¹⁾	Max. connection pressure mbar	Min connection pressure mbar
BG400-2,M				
G20 61-325	6.4	34,2	360	see data plate
G25 61-310	7.4	37,8	360	
G30 61-340	1,9	10,5	360	
G31 61-350	2,5	14,2	360	

¹⁾ Lower heat value Hu at normal state 15°C and 1013.25 mbar EN676				
Grade of gas		kWh/Nm ³	MJ/Nm ³	kcal/Nm ³
Natural gas	G20	9.5	34.02	8126
Natural gas	G25	8.2	29.25	6986
Butane	G30	32.5	116.09	27728
Propane	G31	24.6	88.00	21019

Gas quantity and capacity vary according to grade of gas and connection pressure.

2.2.3 Gas categories, approved gases

Only dry gas is permitted for use

Geräte-kategorien Appliance categories	Versorgungsdrücke Supply pressures	Bestimmungsländer Countries of destination
II _{2R/3R}	20-360mBar	BG, CZ, DE, EE, ES, FR, GR, HU, IS, IT, LU, LV, NO, PT, SI, All countries
II _{2H3B/P}	20-360mBar	AT, CH, CY, DK, FI, LT, RO, SE, SK
II _{2H3P}	20-360mBar	GB, IE,
II _{2L3B/P}	20-360mBar	NL, RO
II _{2E3B/P}	20-360mBar	PL
I _{2E(R)B}	20-360mBar	BE
I _{3P}	20-360mBar	BE

2.2.5 Working field

BG 400-2,M

G20, 61-325 kW

G25, 61-310 kW

G30, 61-340 kW

G31, 61-350 kW

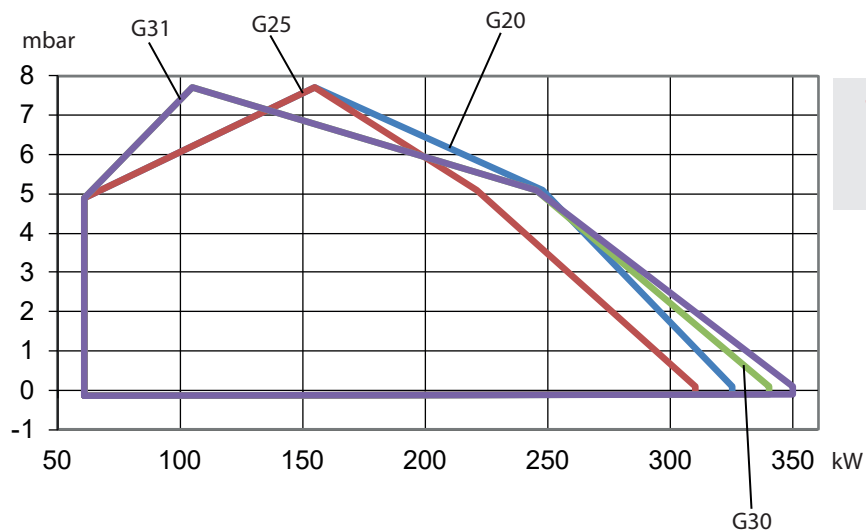

! Do not exceed working field

2.2.4 Electric Specification EN 60335-2-102

Burner correspond to IP20

Type	BG 400
Motor	250W 230V 1,7A 50Hz
The recommended main fuse motor	C10A
Control power	230V 2,2A 50Hz
Sound	85 dBA ± 0,5 dBA

Measurements according to EN 3746: 2010

Alt.1 The sound level of the burner can be reduced by equipping the burner with silencer. Installation must be done so it does not prevent air supply to the burner.

Alt.2 The burner's noise level can be reduced by connecting the burner's air intake to the air duct that opens into an appropriate location. Installation must be done so it does not prevent air supply to the burner.

2.3 Description BG 400

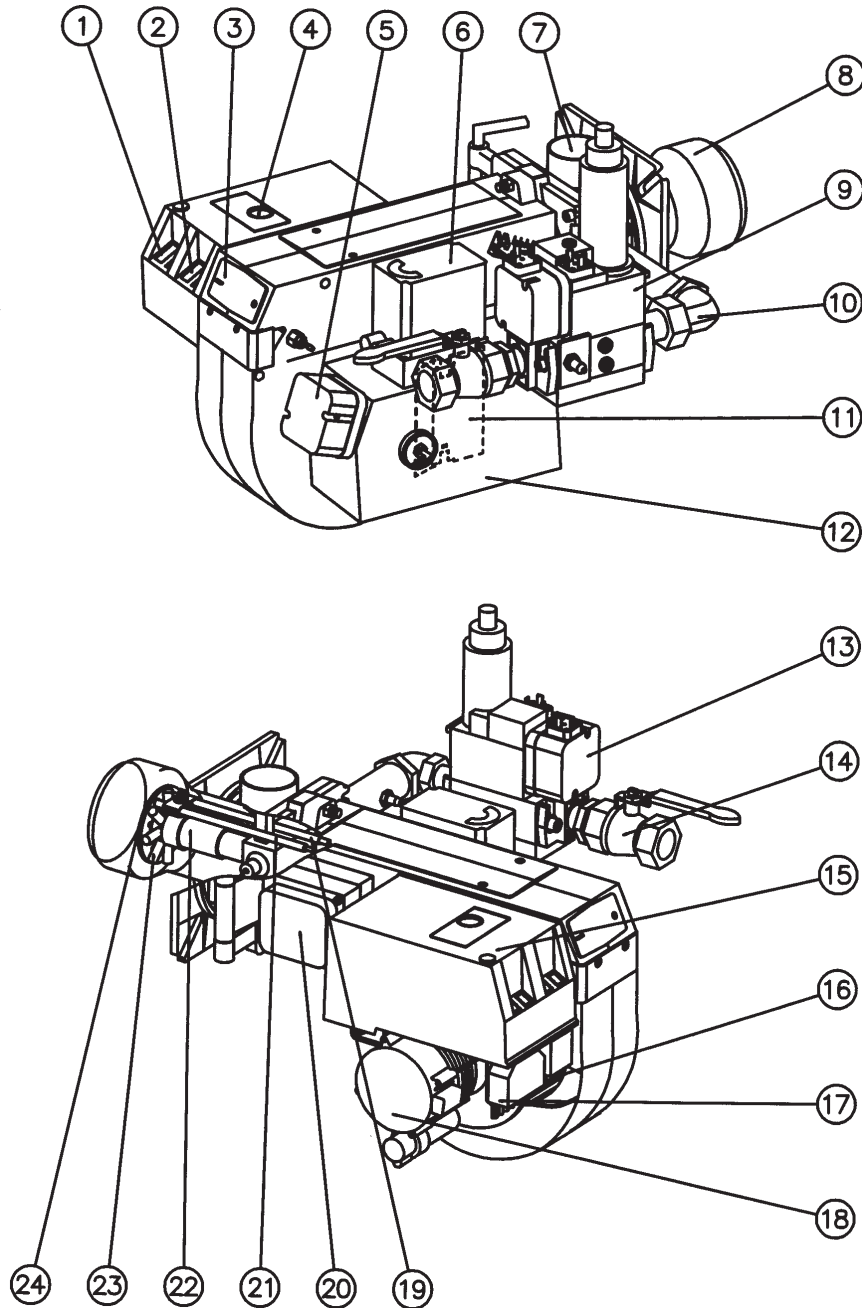

Components

- | | | |
|--|---------------------------|--------------------------|
| 1. Switch 0-I | 9. Multibloc | 18. Motor |
| 2. Switch I-II | 10. Connecting pipe | 19. Ignition electrode |
| 3. Cover, inspection glass | 11. Air damper | 20. Transformer |
| 4. Reset button | 12. Air intake | 21. Ionization electrode |
| 5. Air pressure switch | 13. Gas pressure switch | 22. Inner assembly |
| 6. Damper motor | 14. Ball valve | 23. Nozzle |
| 7. Inner assembly adjustment
(not for town gas) | 15. Electrical panel | 24. Brake plate |
| 8. Flame cone | 16. Fan wheel | |
| | 17. Electrical connection | |

3. General instructions

3.1 General instructions

The installation of the gas burner must be carried out in accordance with current regulations and standards. The installers of gas burners should therefore be acquainted with all regulations and ensure that the installation complies with the requirements. The installation, mounting and adjustment should be made with the greatest care and only the correct gas should be used.

3.2 Installation and maintenance instructions

The maintenance instructions supplied with the burner must be kept at an easily accessible location in the boiler room.

3.3 Instructions

The user should be thoroughly instructed in the function of the gas burner and the whole installation. The supplier must instruct the user.

3.4 Inspection and maintenance

See service schedule.

3.5 Start up

After the burner has been fitted to the boiler and the electric connection, the leakage control, the venting and the electric function test have been carried out, the burner will be ready for start-up.

However, study the sections dealing with adjustments of multi-bloc, combustion air and combustion head. Open the ball valve and switch on the main switch. If the burner starts the actual adjustment can be made.

3.6 Commissioning of installation

Control of the combustion. The combustion quality is checked by means of a flue gas analysis device. Adjust the burner to appr. 20%

excess air in accordance with the table. Check the flue gas temperature. Calculate the efficiency. Check also the actual gas volume on the gas meter so that the correct input is achieved.

4. Installation

4.1 Delivery check

Check that all has been delivered and that the goods have not been damaged during transport. If that is not the case, please notify the delivery company. Transport damages should be reported to the forwarding agency.

4.2 Preparations for installation

Check that the measurements and capacity range of the burner are compatible with the boiler. The power ratings on the type plate refer to the min. and max. power of the burner.

4.3 Gas supply

For good operating safety, it is important that the gas supply system is installed correctly.

Consider the following:

1. Check that the burner is approved for the gas quality of the installation. If not, please contact the supplier.
2. Check that the gas components of the burner are approved for indicated gas pressure.
3. The gas supply system should be installed in accordance with current standards.
4. Pipe lines should be run so that service on boiler and burner is facilitated.
5. Pipe lines should be run so that eventual contaminants cannot come into contact with the gas components.
6. Gas discharge system must be installed prior to local regulations.

4.4 Electric connection

Before starting the electric installation, the main switch must be turned off. If the boiler has a 7-pole and a 4-pole Eurostecker connector, these usually fit directly to the burner. If not, use the connectors included.
(Refer to connection under Electric equipment)



If an electric connection other than the one recommended by Enertech is used, a risk of damage and injury can arise.

4.5 Skeleton diagrams

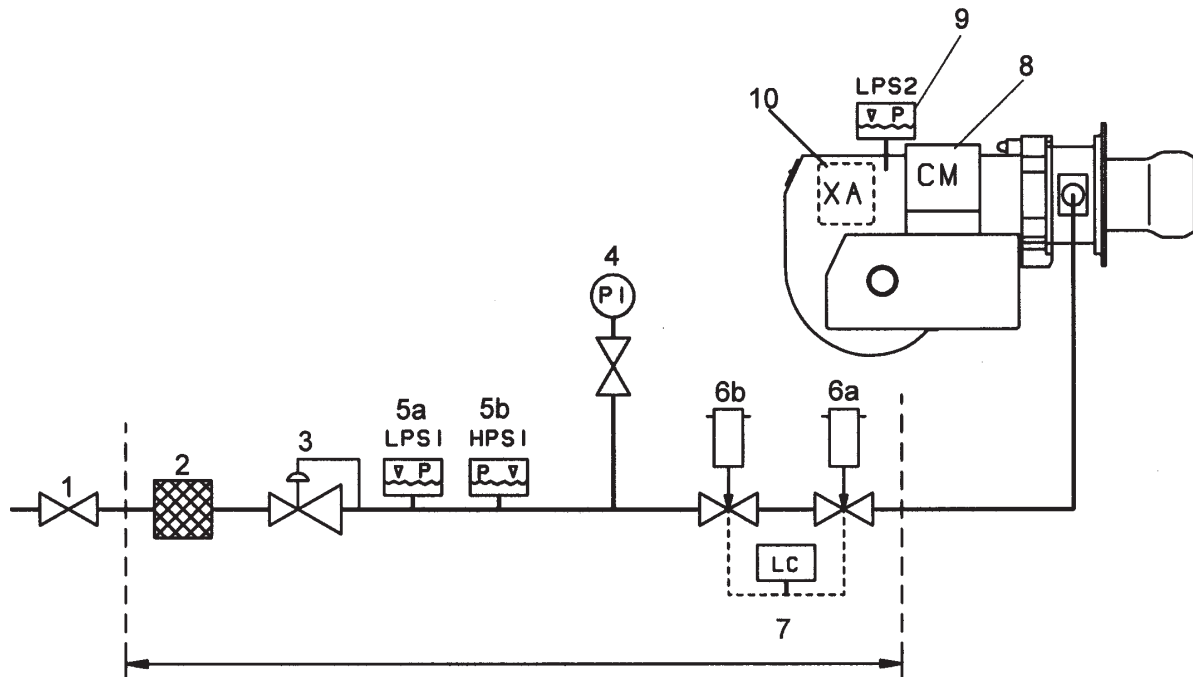

1. Ball valve
2. Filter
3. Governor
4. Pressure gauge with shut-off cock
- 5a. Gas pressure switch, mini
- 5b. Gas pressure switch, maxi
- 6a. Main valve, 2 -stage. When modulating operation is required this valve is equipped with controls for variable opening.
- 6b. Safety valve
- 1)7. Valve proving system
9. Air pressure switch
10. Gas burner control

Pos. 5b, 7: Components not required according to EN 676.

- 1) Required over 1200 kW according to EN 676.hhh

4.6 Mounting on the boiler

Remove the combustion unit from the burner. Fit the enclosed flange and gasket to the boiler. If new fixing holes must be drilled, use the fixing flange as a pattern.

Removal of valve unit from burner

Remove the plug-in contact from the multi-bloc. Loosen the union nut.

Removal of fan house unit from burner.

Remove the screws (A). Swing out the fan housing. Remove the ionisation and ignition wires from the electrodes. Remove the bolt (B) on the spectacle flange. Lift away the fan housing.

Installation example

Connect the gas to the burner by means of the ball valve. Ensure that the union nut, ball valve and tubing make it easy to remove the burner for inspection and service.



Check the gas tightness.

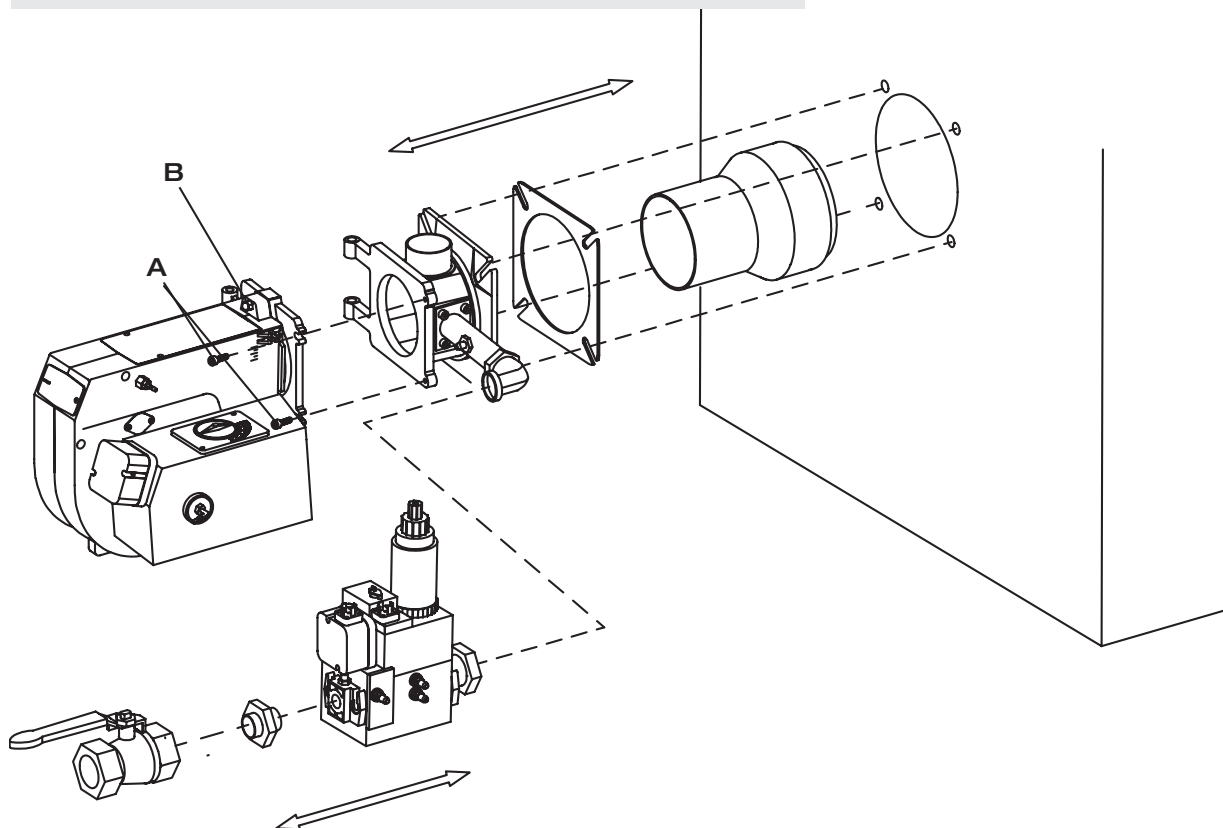

4.7 Inspection of gas nozzle before commissioning

General rules

Care should be taken by the installer to ensure that no electrical cables or fuel/gas pipes are trapped or damaged during installation or service/maintenance.

Gas nozzle

Check that the ignition and ionisation electrodes are correctly set. In the figure (see the gas nozzle chapter), the dimensions are specified for adjustment of the ignition and ionisation electrodes.

Gas quality

Ensure that the burner head is meant for the gas quality to be used (see chapter gas nozzle).

De-aerating

De-aerating of the gas line is conducted, for example, by unscrewing the screw on the measuring nipple for the connection pressure. Connect a plastic hose and release the gas in a safe place. Once de-aerating is completed, be sure to refit the screw on the measuring nipple.

Leakage control

When making a leakage control of the gas supply system the solenoid valve should be closed. Connect a pressure gauge to the test nipple Pa, see fig. The test pressure in the system should be 1,5x max. inlet pressure or min. 150 mbar. If any leakage, locate the source by means of soapy water or a leak location spray. After tightening repeat the test.

Electric function test:

Ensure that phase and neutral are not reversed. The gas shut-off cock should be closed. To prevent the gas pressure switch from locking out it should be linked temporarily.

After the main switch has been switched on and the thermostats have been adjusted the pre-purging period begins (30-35sec.). At the end of this period the pre-ignition period starts (0,5-2,5 sec. dependent on the design of the gas control). The gas valve is energized and opens and flame is established. At the end of the safety time (2-3 sec.) the gas control locks out. The solenoid valve and the motor will be "dead". Remove the link from the gas pressure switch after the test is finished.

Note on 2-stage and modulating burners that during the pre-purging period the damper opens to the set value for air on stage 2 and just before the end of the pre-purging period it goes down to the air setting for stage 1. On some burners under 350kW the pre-purging mainly takes place with the air damper set for stage 1.

! If the burner is directly connected, ensure that all components on the burner are without power.

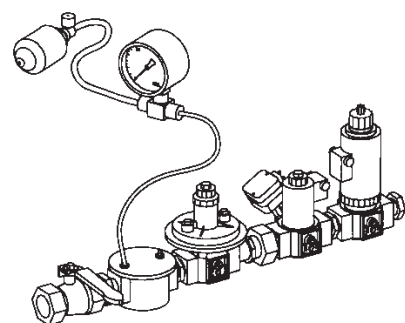
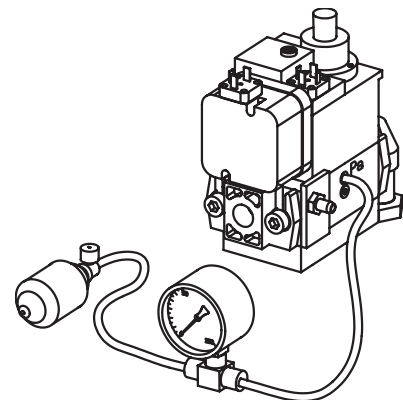

4.8 Gas nozzle

Propan

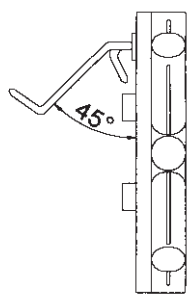

Natural gas

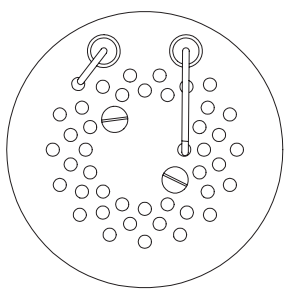
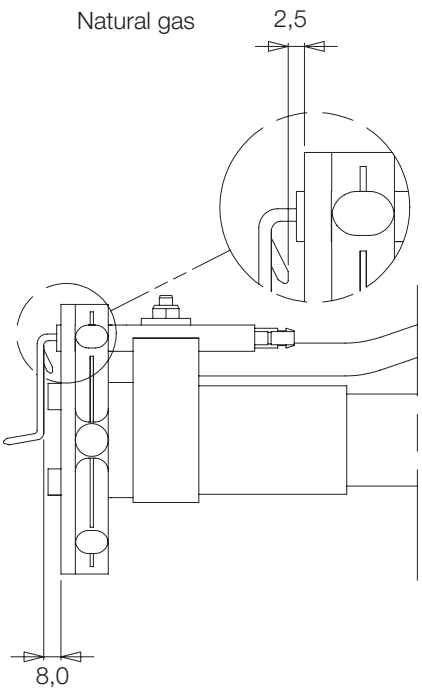

Biogas (UV detector)

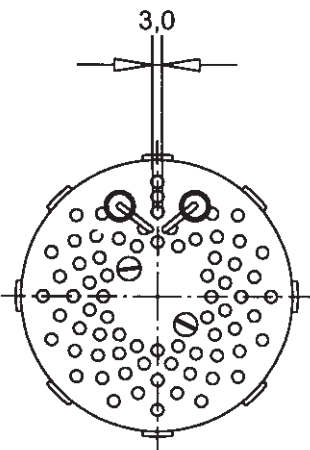
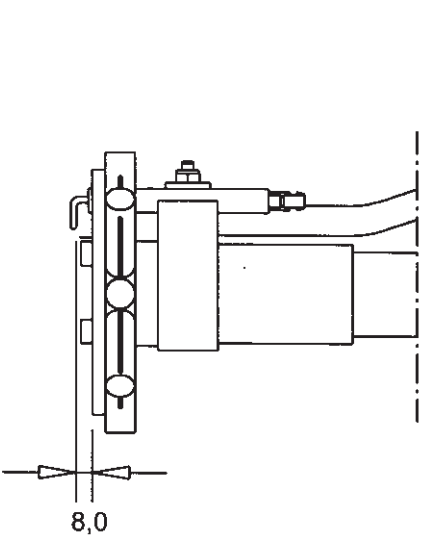

4.11 Setting Air damper

4.12 Damper motor, air volume

Adjust the orange cam for min. load (about 5-10 on scale)

Adjust the red cam for max. load (90°)

The blue cam is factory set for closed position during standstill

The black cam has no function at modulating operation

4.13 Adjustment of gas flow

- Before the burner starts vent the lines to make sure that there is gas available at the multibloc
 - Use an allen key size 2,5 mm for adjusting N and V.
 - Connect a pressure gauge for measuring PBr, (advisable to find out if the valves are open)
 - Set the switch in position MAN.
 - Set the gas pressure switch min. and air pressure switch on min. adjustment. Set the gas pressure switch max, if any, on max. adjustment.
 - Start the burner, observe the pressure gauge, if no flame is established and the pressure gauge needle does not flicker, increase N. When the flame is established adjust the gas flow by means of the screw N. Use a flue gas instrument.
 - Change over to max. load, press the switch "increase"
 - Adjust the gas flow with V and check at the same time the combustion values.
 - Go back to min. load and check the combustion value. Adjust if necessary.
 - If necessary repeat the controls of the adjustment made on min. (N) and max. load(V).
 - Increased power on minimum and maximum have now been adjusted by changing the orange cam and red cam. Check the gas flow on the gas meter available on the installation.
 - Note! Do not forget to set the air and gas pressure switches after the adjustment, see special instructions.
- **Releasing button**

By pressing the button and snapping it down, the motor will be released and the damper can easily be turned. This function facilitates an exchange of damper motor.

Releasing button

N.B! The upper position is the standard position!

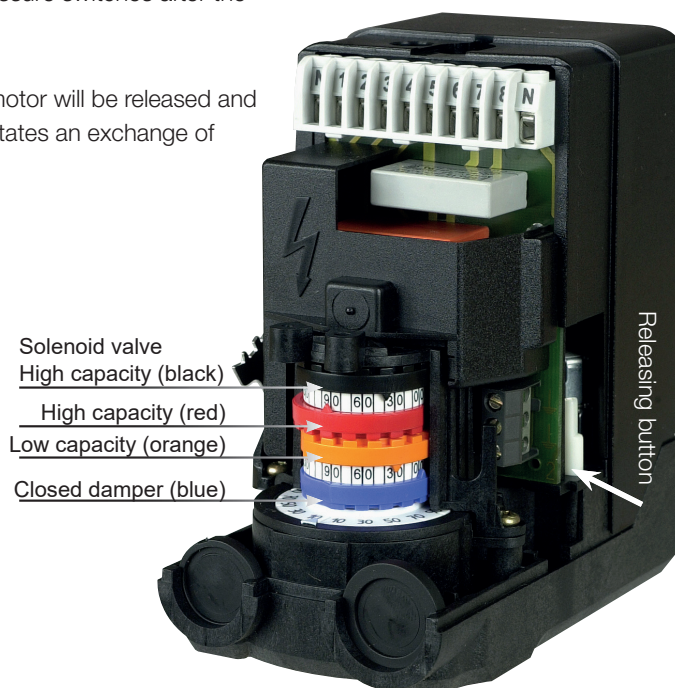

172 515 15 2018-01-03

5. Setting the burner

5.1 Adjustment of brake plate

-Loosen the screw on the adjustment device.

-To reduce the opening: turn the knob to the left.

-To increase the opening: turn the knob to the right.

The adjustment of the position of the brake plate affects the air flow. It is therefore always necessary to make a fine adjustment of the air by means of the adjustment device of the burner.

5.2 Control of burner head

To check the burner head, brake plate and electrodes proceed as follows:

Loosen the nuts a. Swing out the burner. Remove the screw b and the knob for adjustment of burner head. Loosen the screw c so much so that the inner assembly can be pulled out.

Adjustment of inner assembly

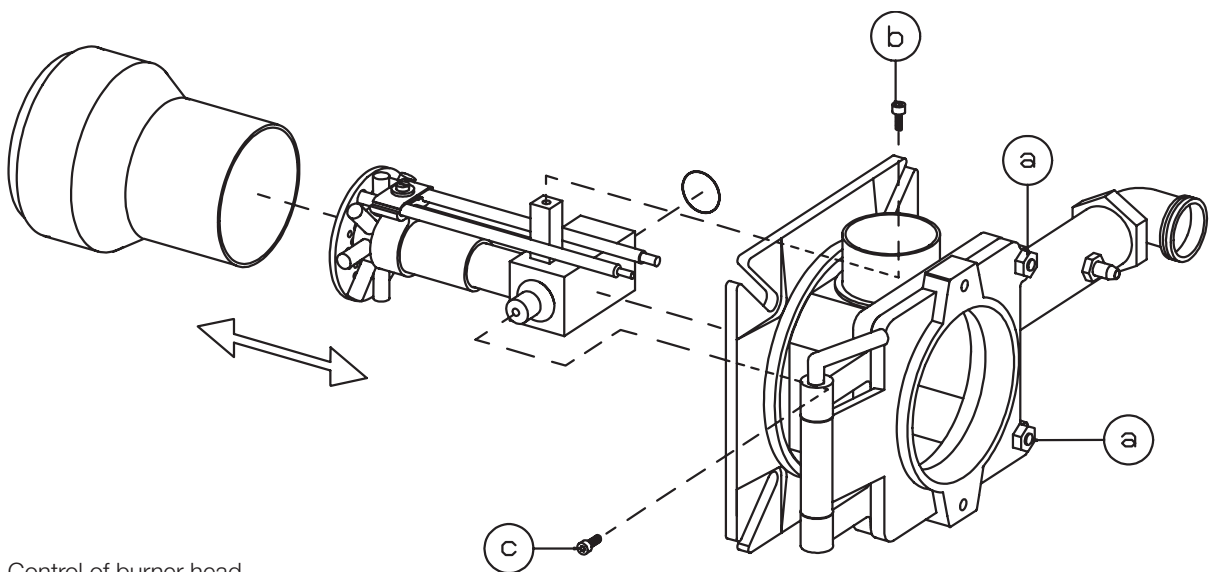
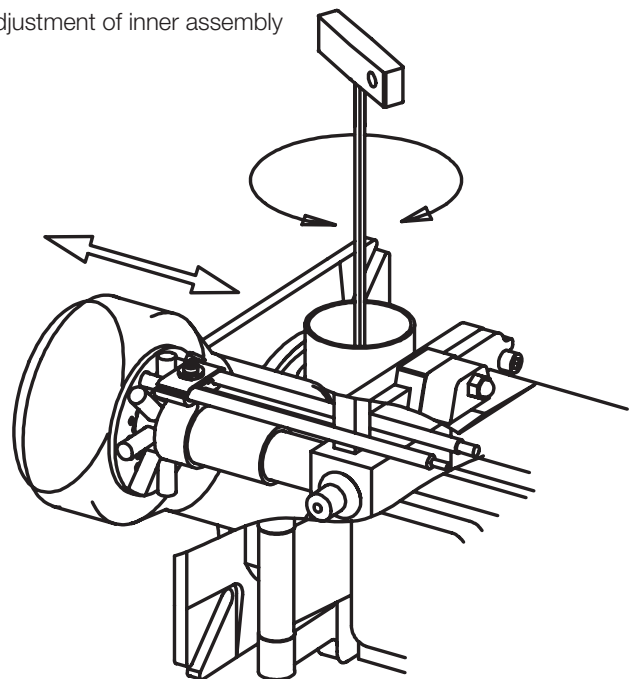

Control of burner head

General instructions

The installation of the gas burner must be carried out in accordance with current regulations and standards. The installers of gas burners should therefore be acquainted with all regulations and ensure that the installation complies with the requirements. The installation, mounting and adjustment should be made with the greatest care and only the correct gas should be used.

Operating instructions

The installation and maintenance instructions supplied with the burner must be kept at an easily accessible location in the boiler room.

Instructions

The user should be thoroughly instructed in the function of the gas burner and the whole installation. The supplier must instruct the user.

Inspection and maintenance

Inspection as needed, preferably daily. Maintenance per service schedule.

Start up

After the burner has been fitted to the boiler and the electric connection, the leakage control, the venting and the electric function test have been carried out, the burner will be ready for start-up.

However, study the sections dealing with adjustments of multi-bloc, combustion air and combustion head.

Open the ball valve and switch on the main switch. If the burner starts the actual adjustment can be made.

Adjustment of burner head

The burner is equipped with an adjustment device changing the position of the brake plate in the burner head. This is used to adjust the correct pressure drop over the combustion device in order to obtain a good pulsation free combustion.

Which position to use depends on input and overpressure in the boiler.

A general rule is that the lower capacity the smaller the opening between brake plate and combustion device.

Commissioning of installation

Control of the combustion. The combustion quality is checked by means of a flue gas analysis device. Adjust the burner to appr. 20% excess air in accordance with the table. Check the flue gas temperature. Calculate the efficiency. Check also the actual gas volume on the gas meter so that the correct input is achieved

Service

Service should only be carried out by qualified personnel. Replacement parts should be of the same make and approved by the same authorities as the original. If the burner is converted to fire another gas quality it must be re-commissioned. If town gas is to be fired the combustion head must be converted and the gas train adjusted to suit (e.g.a larger gas armature or a different spring in the governor may be required).

Gas quality	CO ₂ % lambda 1,2	O ₂ %	max. CO ₂ %
Natural gas	10,0	3,5	11,9
LPG	11,5	3,5	13,9

5.3 Setting the air pressure switch

The air pressure switch should block the burner if the air quantity supplied for combustion is insufficient. The air pressure switch must be set so that, if there is a defective air supply at the burner's max. or min. capacity, it reacts before the monitored pressure falls so much that it results in poor combustion.

Inställningsområde ca:

LGW 10	1-10	mbar
LGW 50	2,5-50	mbar

Setting for air pressure switch

1. Remove the protective cover, screw (Y).



Be careful when adjusting the air pressure switch; it contains a live component.

2. Start the burner.
3. Carefully turn the scale on the air pressure switch clockwise until the air pressure switch stops the burner. **Is the tolerance on the scale for the min. air pressure switch approx. $\pm 15\%$?**
4. Try to find the pressure at which the burner stops for both the minimum and maximum input power by turning the scale. Make a note of the values and then set the air pressure switch on the basis of the highest pressure noted at which the burner stopped.
5. The air pressure switch should be set to a pressure approx. 10–15% lower than the highest noted pressure at which the burner stopped.
6. After setting the air pressure switch, perform repeated starts and run through the burner's set output range several times. This is to ensure the reliable function of the burner. If breakdowns or interruptions occur, the air pressure switch is probably set to a too narrow position.
7. Fit the protective cover, screw (Y).



5.4 Setting the min. gas pressure switch

The min. gas pressure switch should react to a burner connection pressure that is too low and in such cases prevent the burner from starting. If the connection pressure to the burner is too low during operation, the min. gas pressure switch should stop the burner. The burner can start again once the connection pressure has risen above the pressure set for the min. gas pressure switch.

Setting for min. gas pressure switch

1. Remove the protective cover, screw (Y).
2. Open the pressure outlet (X) and connect a manometer to measure the connection pressure.
3. Start the burner.
4. Measure and make a note of the connection pressure to the burner during normal operation at the highest input power.
5. Based on the desired connection pressure set, determine the connection pressure at which the gas pressure switch should stop the burner. Set the connection pressure at which the burner is stopped at a level where the burner is stopped before poor combustion occurs.
6. Set the min. gas pressure switch to this value by turning the scale.
7. Check the setting by carefully closing the ball valve while measuring the connection pressure.
8. When the min. gas pressure switch stops the burner, the value measured should then approximately correspond to the setting on the min. gas pressure switch. The tolerance on the scale for the min. gas pressure switch is approx. $\pm 15\%$.
9. Open the ball valve.
10. Remove the pressure gauge and close the pressure outlet (X).



Check the gas tightness.

11. Fit the protective cover, screw (Y).



6. Multibloc MB-VEF B01, 407-412

! All gasline components shall be assembled and mounted without bending, torque and other mechanical or thermal stress.

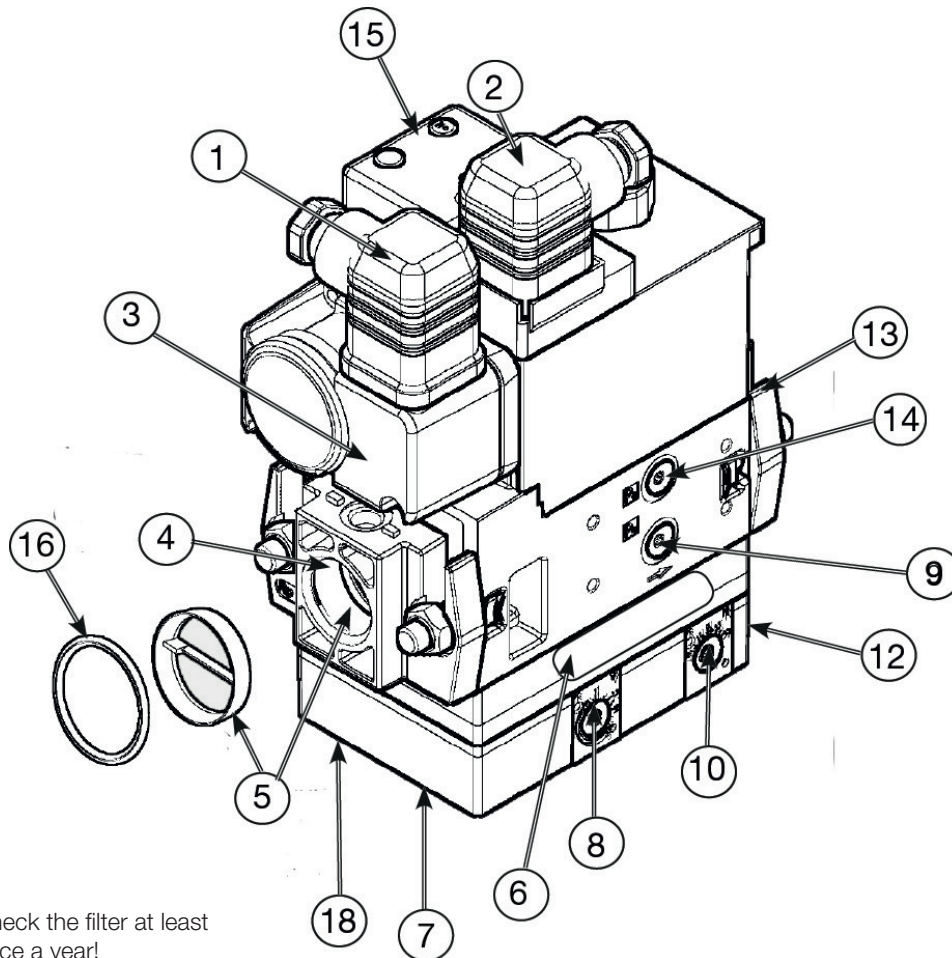

Check the filter at least once a year!

Components

- | | | |
|---|--|---|
| 1. Electrical connection gas pressure switch mini | 7. Connection 1/8" P_L | 12. Test point connection 1/8" P_{Br} |
| 2. Electrical connection gas valve | 8. Adjustment screw V for ratio $P_{Br} : P_L$ (max. load) | 13. Flange connection, outlet |
| 3. Pressure switch mini | 9. Test point connection 1/8" before V1 (before governor) | 14. Test point connection 1/8" P_a before V2 (after governor) |
| 4. Flange connection inlet | 10. Adjustment screw for zero point adjustment N (min. load) | 15. Indication of V1 and V2 in operation (not standard) |
| 5. Filter | 11. Test point connection 1/8" P_F | 16. O-ring |

It is possible to connect a leakage control VPS 504 and a gas pressure switch maxi.

1) **NB.** The impulse line P_{Br} can be replaced by an impulse flange on the multibloc. The impulse line P_{Br} is then placed inside this flange.

Technical data

- Max inlet pressure 360 mbar
- Valves V1+V2 class A group 2 in accordance with EN 161
- Governor class A group 2 in accordance with EN88-1
- Ratio V PBr:PL 0,75:1-3:1
- Filter according to DIN 3386
- Ambient temperature -15°C- +70°C
- Protection standard type IP54 (according to IEC 529, DIN 40050)
- Gas family 1 +2 +3
- Outlet pressure 0,5 - 100 mbar
- Zero point adjustment $N \pm 2$ mbar
- Pressure switch DIN3398 TI
- Fan pressure PL0,4-100 mbar
- Fire room pressure PF -2 -+5mbar
- Burner pressure PBr 0,5 - 100 mbar

Mounting instruction - impulse lines P_L , P_F och P_{Br}

- Impulse lines should preferably be made of steel. Inside diameter $> \phi 4$ mm (steel tube $\phi 6/4$)
- For P_L other material can be used.
- Impulse lines P_L and P_{Br} are ready from factory
- Impulse lines shall be mounted in such a way that no condensate can flow back into the multibloc. This is especially important when P_F is concerned.
- Impulse lines shall be mounted in such a way that they are protected against rupture and damage.
- Impulse lines shall be as short as possible

Adjustment possibilities



Effective burner pressure

$$\Delta P_{Br} = P_{Br} - P_F$$



Effective fan pressure

$$\Delta P_L = P_L - P_F$$

Adjustment range

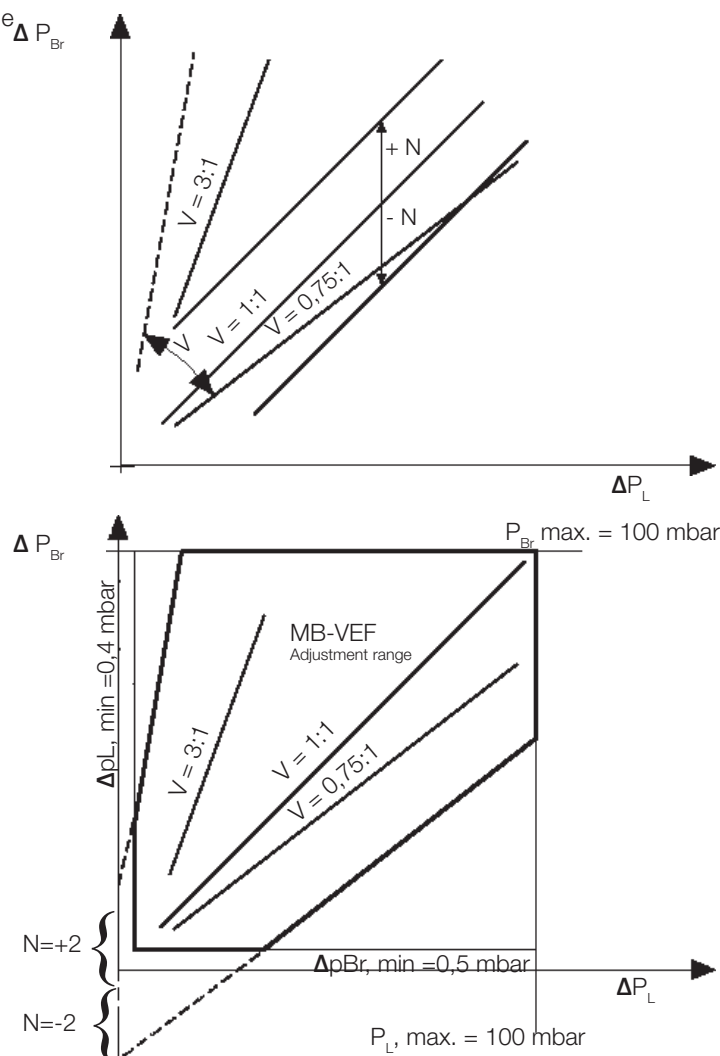

6.4.1 Pressure taps

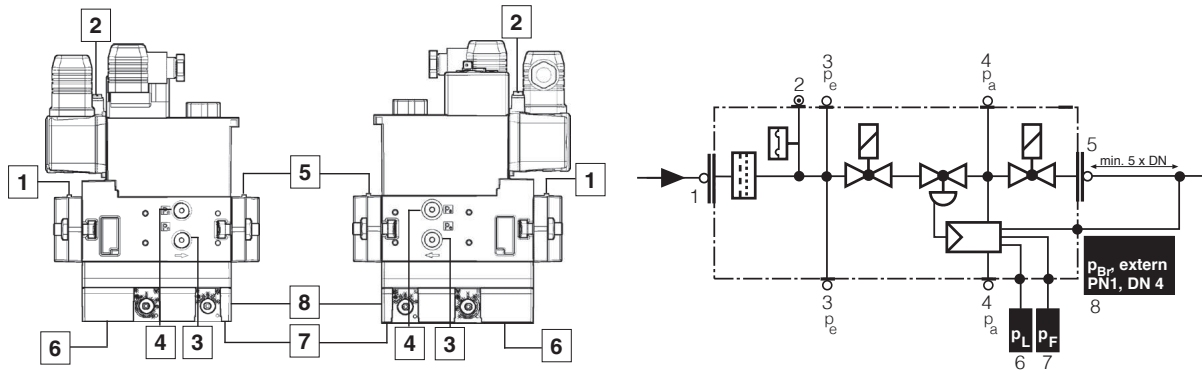

1,3,4,5 G 1/8 screwed sealing plug

2 Measuring nozzle

6,7,8 G 1/8 female thread for p_L , p_F , p_{Br} pulse lines

6.4.2 Electrical connection

S 10/S 30

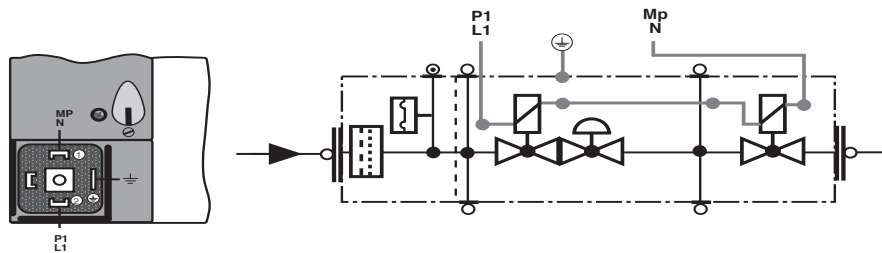

5.7 Recommended excess air when using default setting

Grade of gas	Excess air flue gases		Max. % CO ₂
	% O ₂	% CO ₂ Lambda 1.2	
Natural gas	3–5	≈10	11.9
Propane	3–5	≈11.5	13.9
Butane	3–5	≈11,5	14,1
Liquefied petroleum gas (LPG)	3–5	≈11	13,8

5.8 Determining the gas quantity for the system

The heat values indicated are normal values; the heat value varies according to the origin of the gas. For more exact information on values, contact the gas distributor.

Lower heat value Hu at normal state 15°C and 1013.25 mbar EN676

Grade of gas		kWh/Nm ³	MJ/Nm ³	kcal/Nm ³
Natural gas	G20	9.5	34.02	8126
Natural gas	G25	8.2	29.25	6986
Propane	G31	24.6	88.00	21019
Butane	G30	32.5	116.09	27728

5.8.1 Example of how to calculate the gas quantity (natural gas G20):

V_o =	Desired quantity of gas	[Nm ³ /h]
Q =	Boiler output	[kW]
H_u =	Gas heat value	[kWh/Nm ³] or [MJ/Nm ³] or [kcal/Nm ³]
η =	Boiler efficiency	[%]

Calculation example:

$$Q = 160 \text{ kW}$$

$$H_u = \text{Example A: } 34020 \text{ MJ/Nm}^3$$

$$\text{Example B: } 9.5 \text{ kWh/Nm}^3$$

$$\text{Example C: } 8126 \text{ kcal/Nm}^3$$

$$\eta = 90\%$$

$$V_{oA} = \frac{Q \cdot 3600}{H_u \cdot \eta} = \frac{160 \cdot 3600}{34020 \cdot 0.90} \approx 18.8 \text{ Nm}^3/\text{h}$$

$$V_{oB} = \frac{Q}{H_u \cdot \eta} \approx \frac{160}{9.5 \cdot 0.90} \approx 19 \text{ Nm}^3/\text{h}$$

$$V_{oC} = \frac{Q}{H_u \cdot 0.00116 \cdot \eta} = \frac{160}{8126 \cdot 0.00116 \cdot 0.90} \approx 19 \text{ Nm}^3/\text{h}$$

If the barometer reading (altitude), pressure and temperature of the gas deviate significantly from normal values, this must be taken into account as follows:

T =	Temperature of gas at the gas meter	[°C]
B =	Barometer reading	[mbar]
P =	Pressure of gas at the gas meter	[mbar]
f =	Factor calculated for multiplication with flow in Nm ³ /h to arrive at actual flow in m ³ /h.	
V =	Actual flow	[m ³ /h]
f =	$\frac{273}{273+T} \cdot \frac{B+P}{1013.25}$	

Calculation example:

$$T = 15^{\circ}\text{C}$$

$$B = 945 \text{ mbar}$$

$$P = 15 \text{ mbar}$$

$$f = \frac{273}{273+15} \cdot \frac{945+15}{1013.25} \approx 0.90 \text{ Nm}^3/\text{h}$$

This means that the quantity of gas read from the gas meter should actually be read off as 1.11 . the calculated flow in a normal state.

$$\begin{aligned} V &= V_0 \cdot f \\ V_A &= V_{0A} \cdot f = 18.8 \cdot 0.90 \approx 17 \text{ m}^3/\text{h} \\ V_B &= V_{0B} \cdot f = 19 \cdot 0.90 \approx 17 \text{ m}^3/\text{h} \\ V_C &= V_{0C} \cdot f = 19 \cdot 0.90 \approx 17 \text{ m}^3/\text{h} \end{aligned}$$

5.9 Calculating the quantity of gas supplied

The quantity of gas supplied can be calculated if the system is equipped with a gas flow meter of some type. The procedure here is usually to measure how long it takes for the burner to consume a certain quantity of gas.

To measure:

t = Time for a certain quantity of gas consumed by the burner. [h]

M = Quantity of gas consumed. [m³]

V = Actual gas flow [m³/h]

$$V = \frac{M}{t} \text{ [m}^3/\text{h]}$$

Calculation example:

$$t = 1 \text{ min } 10 \text{ s}$$

$$M = 330 \text{ dm}^3 \text{ (litre)}$$

$$M = \frac{330}{1000} = 0.33 \text{ m}^3$$

$$t = \frac{1}{60} + \frac{10}{3600} = 0.0194 \text{ h}$$

$$V = \frac{M}{t} = \frac{0.33}{0.0194} \approx 17 \text{ m}^3/\text{h}$$

7. Service

Whoever carries out service and maintenance on the burner must be authorised to do so. If components need to be replaced, the replacements must be of the same make and type and be approved by the authorities. If the burner is to be used for a different grade of gas, a new adjustment must be carried out. If town gas is to be used, it is also necessary to convert the combustion assembly; in some cases the multi-block or valves and gas train may also need to be changed to a larger type.

7.1 Servicing the combustion assembly

Removal and installation

1. Switch off the main power supply and disconnect the Euro plugs from the burner.



If the burner is directly connected, ensure that all components on the burner are without power.

2. Remove the screws (A), turn off the burner Remove the ignition and ionisation cables
3. Check the combustion device's position. Remove the screw (B) to remove the adjustment device.
4. Remove the screw (C), remove the combustion device.
5. Check and clean the brake plate and gas inlet. If necessary, replace the worn parts.
6. Check the ignition electrode (see chapter Gas nozzle). Replace if necessary.
7. Check the ionisation electrode (see chapter Gas nozzle). Replace if necessary.
8. Fit the combustion assembly in reverse order.
9. Press the burner together and lock using the nuts (B).
10. Fit the Euro plugs and turn on the main power supply.
11. Check/adjust the combustion.

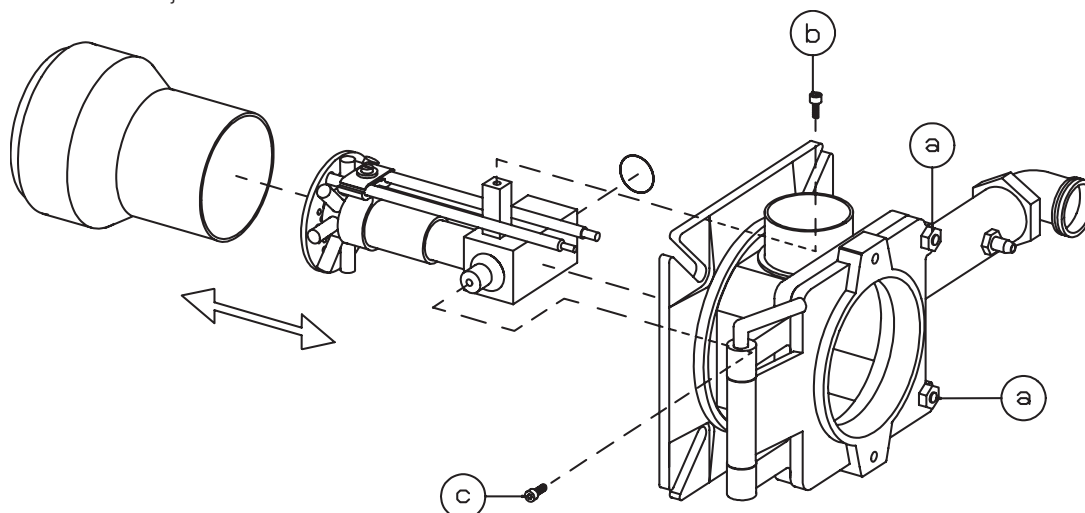

172 615 08 2018-01-03

7.2 Replacement of damper motor, air

Removal and installation

1. Break the main current and disconnect the Euro plugs from the burner.



If the burner is directly connected, ensure that all components on the burner are without power.

2. Note the connection position of the cables on the damper motor.
3. Disconnect the damper motor cable from the damper motor.
4. Loosen the screws (G) to the damper motor mounting plate.
5. Decouple the damper motor and rotate to approx. 70°.
6. Lift up the damper motor.
7. Loosen the screw (H) and remove the damper from the motor shaft.
8. Remove the screws (I) securing the damper motor to the mounting plate.
9. Remove the damper motor from the mounting plate (I).
10. Install the new damper motor on the mounting plate.
11. Mount the damper to the damper motor's shaft. Ensure that the screw is perpendicular to the plane of the shaft.
12. Re-install the damper motor and mounting plate on the air intake. Ensure that the damper shaft and control arm are connected correctly.
13. Connect the damper motor cable.
14. Fit the Euro plugs and turn on the mains power.
15. Check/adjust the combustion.

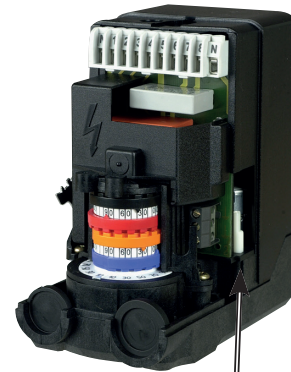

- Releasing button

By pressing the button and snapping it down, the motor will be released and the damper can easily be turned. This function facilitates an exchange of damper motor.

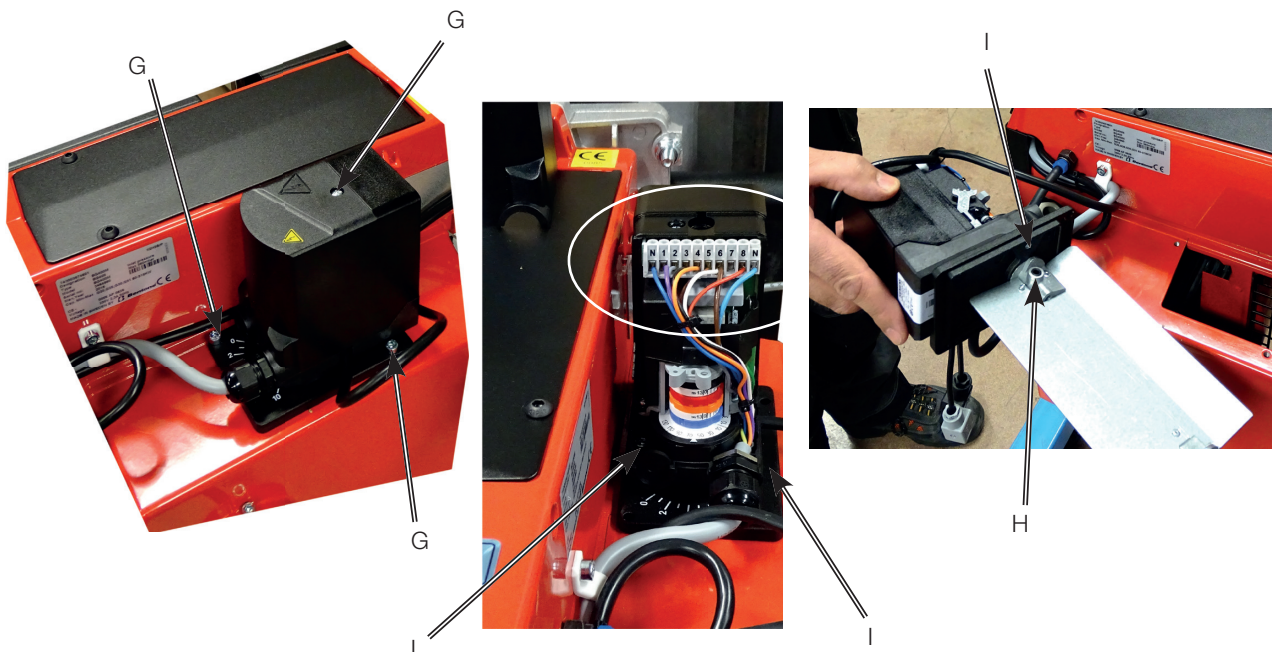

6.3 Flame monitoring and ionisation current check

The standard version of the burner is monitored according to the ionisation principle. The ionisation current should be checked on initial start-up and at each service visit.

The reason for low ionisation current can be leakage current, poor connection to earth, fouling or incorrectly positioned ionisation electrode in the combustion head. Occasionally, an incorrect gas/air mix may result in poor ionisation current. Ionisation current is measured using a microammeter (μA) connected in series with the ionisation electrode and gas burner control. Connect the μ ammeter according to the diagram. The minimum required ionisation current is shown in the table. In practice, this current must be significantly higher, preferably more than $10 \mu\text{A}$. Connection of the μA instrument is made easier by the fact that all gas burners are equipped with a divisible ionisation cable.

Technical data

For continuous operation!

Idle voltage at ION-terminals	AC 115-230 V
 Protect the ionisation electrode from electric shock!	
Short-circuit current	Max. AC 100-300 mA
Min. current for flame detection	Min. DC $1.5 \mu\text{A}$
Required current to ensure detection	Min. DC $3 \mu\text{A}$
Possible detection current	Max. DC $20 \mu\text{A}$
Operational indicator lamp flashes green	$<5 \mu\text{A DC}$
Operational indicator lamp shines green	$>5 \mu\text{A DC}$

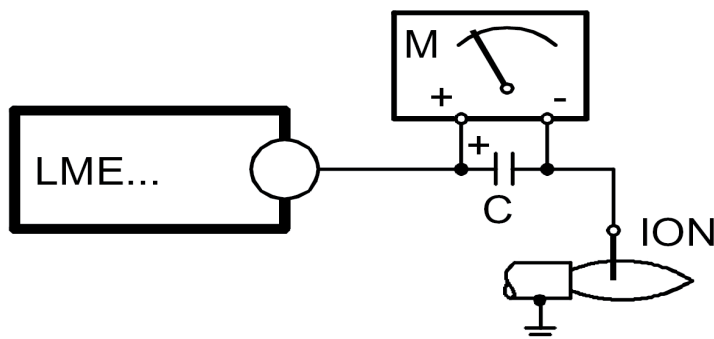

6.4 UV-Detector

DC current detector signals with flame detector QRQ...	Min. required	Max. possible
Measurement at the flame detector QRA...	200 μ A	500 μ A

Ancillary unit AGQ3...A27

In connection with burner controls LMExx.xxxx2, use of UV ancillary unit AGQ3...A27 is mandatory. Correct functioning of aged UV cells can be checked as UV test with a higher supply voltage across the UV cell after controlled shutdown until terminal 3 ON.

Connection diagram

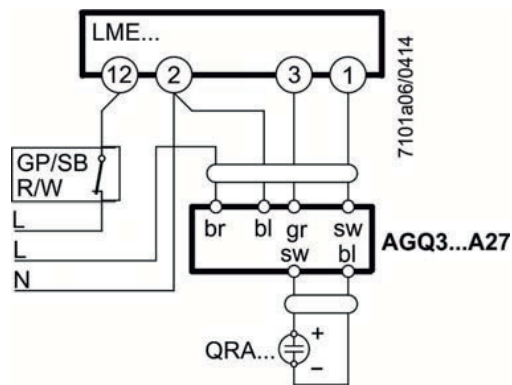

Measuring circuit for measuring the UV flame current

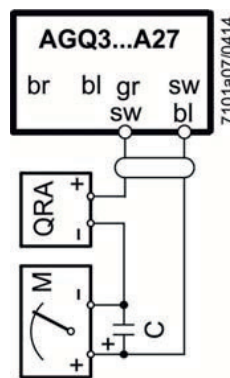

Measurement made at the flame detector QRA...

7. Handing over of the installation

- Make repeated start attempts to ensure that the adjustments function.
- Close the ball valve during operation to check that the gas switch switches off at the set value.
- Remove the hose for the air pressure switch to check that the burner locks out.
- Check that all protective covers and measurement nipples are mounted and fastened.
- Fill out necessary test reports.
- Instruct the persons in charge of the operation on the service and maintenance of the installation and what to do should any troubles occur.
- Inspection and service must be carried out by authorized personnel.



Review and service should be performed by authorised personnel only

8. Fault location, functional troubles

Trouble free operation is dependent on three factors: electricity, gas and air supply. Should there be any changes in the ratio between these three factors there is a risk of break downs. It has been proved that most break downs are caused by simple faults. Before calling the service engineer, the following should therefore be checked:

- Is the gas cock open?
- Are all fuses in order and the current switched on?
- Are the thermostats correctly set?
- Are pressostats, overheating protection etc. in operating position and not locked-out?
- Is the gas pressure sufficient?
- Is the gas burner control in start position?
- Has the gas control or the motor protector locked out? - Reset.
- Is the circulation pump in operation?
- Is there a supply of fresh air to the installation?
- If integral components are of a different make from what is stated in this manual, see the enclosed loose-leaf.

9. Electric equipment

9.1 Safety system

Safety systems must be installed in accordance with regulations that are applicable for the appliance. This may differ according to the process burner are installed in to. Se local regulations for information.

Safety system cables must be run in separate cables outgoing signal must not come in same cable as incoming signal. Signals must be in different harnesses for safety reasons.

Safety system as door switches, water level, pressure, temperature and other safety limiters must be installed in safety loop according to process.

9.2 Wiring diagram LME

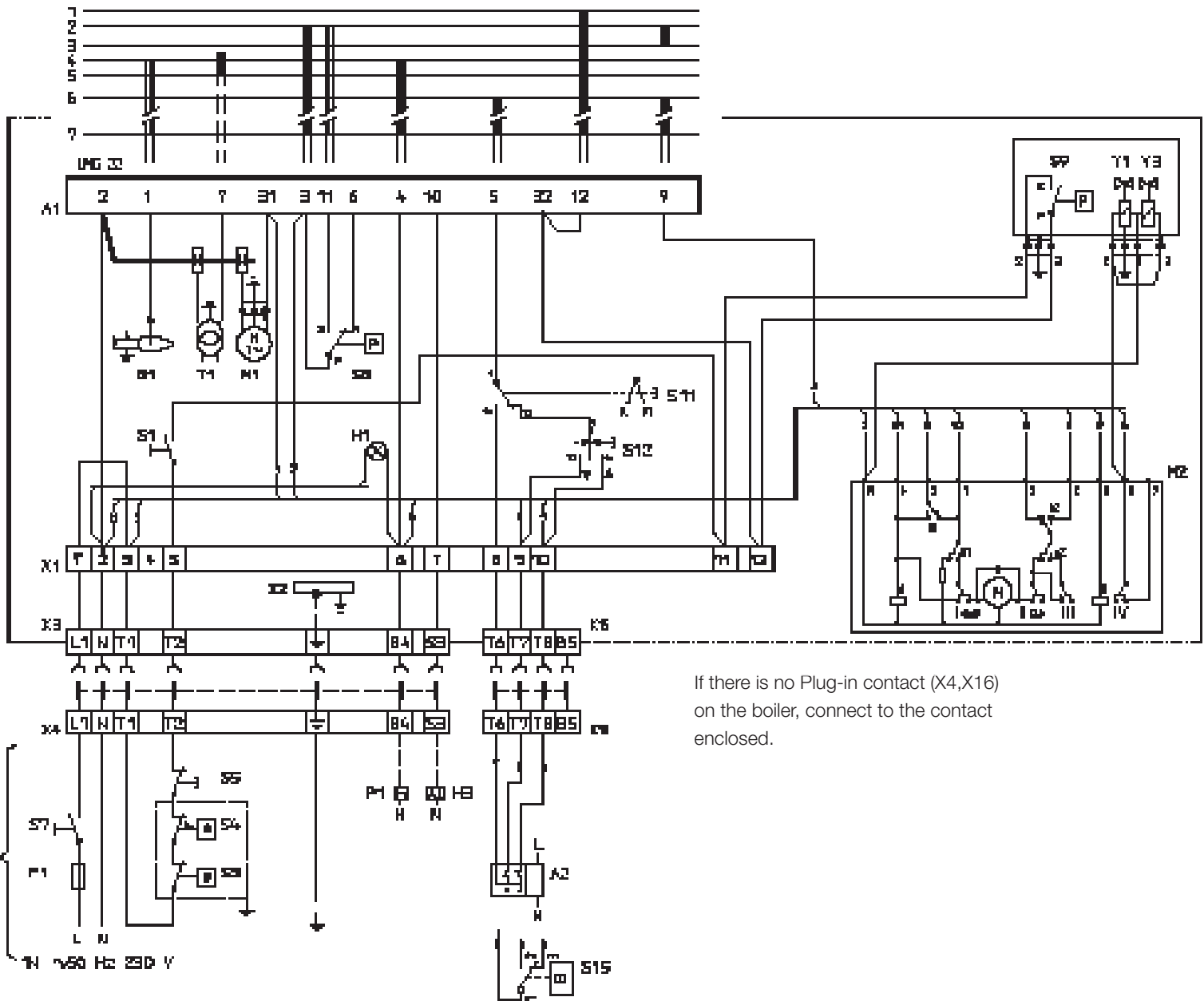

9.3 List of components

A1 Gas burner control	S3 Control thermostat	X1 Connection terminal board
A2 Power control	S4 Temperature limiter	X2 Earth terminal
B1 Ionization electrode	S5 Micro switch for hinged door	X3 Plug-in contact, burner
F1 Operating fuse	S7 Main switch	X4 Plug-in contact, boiler
H1 Operating lamp	S8 Air pressure switch	X15 Plug-in contact, power controller, burner
H3 Alarm signal 230 V	S11 Change-over switch, Aut.-Man.	X16 Plug-in contact, capacity regulator, boiler
M1 Burner motor	S12 Change-over switch, Increase-Reduce	S9 Gas pressure switch
M2 Damper motor, L&S SQN75.624A21B	S15 Control thermostat, 3-pole (only for 2-stage sliding)	Y1 Gas solenoid valve 1
P1 Time meter, total operating time	T1 Ignition transformer	Y3 Safety solenoid valve
S1 Operating switch		

9.3.1 Function LME...

<p>1. Operating switch ON-Thermostat ON-Gas pressure switch ON A check that the air pressure switch does not indicate fan pressure is carried out</p>
<p>2. Burner motor starts A check that the air pressure switch indicates sufficient fan pressure is carried out</p>
<p>3. The ignition spark is created</p>
<p>4. The gas solenoid valve is open The gas is ignited. The ionisation electrode now indicates a flame</p>
<p>5. The safety time expires The ignition spark ceases. The safety period ceases. If the spark is missing or it disappears after this time limit, the gas burner control is blocked</p>
<p>6. Operating position</p>
<p>7. Stop The operation of the burner can now be stopped with the control switch or thermostat</p>
<p>If the gas burner control is blocked Red light in the gas burner control is lit. The burner is restarted by pushing the reset button</p>

9.3.1.1 Alarm code table

Red blinking code on signal lamp (LED)	Possible causes
Blinking 2 x ..	No flame creation at End of "TSA" - defective or fouled flame monitoring - defective or fouled fuel valves - poor burner setting - defective firing device
Blinking 3 x ...	"LP" defective - No air pressure switch signal after "t10" - "LP" is welded in open position
Blinking 4 x	Illegal flame signal during start-up
Blinking 5 x	Time out "LP" - "LP" is welded in open position
Blinking 6 x	Free
Blinking 7 x	Too many flame disappearances during operation - poor burner setting - defective or fouled fuel valves - defective or fouled flame monitoring
Blinking 8 x	Free
Blinking 9 x	Free
Blinking 10 x	Connection fault or internal fault, outgoing contacts or other faults
Blinking 14 x	CPI contact not closed

During the diagnosing of the alarm cause, the control outputs are voltage-free.

- The burner is disconnected
- Exception, alarm signal «AL» at board 10
- Reconnection of the burner happens after resetting only.
- Press the reset button 0.5...3 s

9.3.1.2 Interface diagnostics

To change to interface mode, press and hold the reset button longer than 3 s. To go back to the normal position, press and hold the reset button longer than 3 s. If the gas burner control is in the alarm position, it is reset by pressing the reset button 0.5...3 s.

9.4 Control program at faults; fault mode indicator LME

9.4.1 Colour codes

Table colour codes for multi-coloured signal light (LED)		
Status	Colour codes	Colours
Waiting period «tw», other waiting periods	○.....	Off
Ignition phase, ignition controlled	●○●○●○●○●○●	Blinking yellow
Normal operation	□.....	Green
Operation, poor flame signal	□○□○□○□○□○□○	Blinking green
Illegal flame signal during start-up	□▲□▲□▲□▲□▲□▲	Green-Red
Undervoltage	●▲●▲●▲●▲●▲●▲	Yellow-Red
Fault, alarm	▲.....	Red
Blinking code for fault codes	▲○▲○▲○▲○▲○▲○	Blinking red
Interface diagnostics	▲▲▲▲▲▲▲▲▲▲▲▲	Red flicking

.....	Continuous
○	Off
▲	Red
●	Yellow
□	Green

9.4.1.1 Diagnosing alarm causes

After alarm disconnection, the red alarm signal light is lit continuously.

The diagnosing of the alarm cause can be read according to the following sequence:

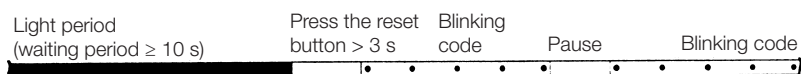

9.4.1.2 Limiting of starting repetitions

LME 11... has a function with start repetition if the flame is not created at start or disappears during operation.. LME 11... allows max. three repetitions during continuous starting cycle.

10. Troubleshooting

Gas Burner

Conditions favourable to disruption-free operation of the system can only be guaranteed through the interaction between three factors – electricity, gas flow and combustion air. A change in any of these factors may cause disruptions.

It has been shown that a large proportion of disruptions can be attributed to relatively small things. Therefore, before requesting servicing, you should ascertain the following:

1. Are the system's gas taps open?
2. Are the fuses intact and is the power on?
3. Are control devices (room thermostat, boiler thermostat, etc.) correctly set?
4. Is gas pressure to the burner sufficient?
5. Are the burner controls on standby and not locked?
6. Is air supply to the burner adequate?

To facilitate troubleshooting, we have created a table of the most common faults that may arise in a gas burner system and how they should be rectified.

Cause of fault	Action
Burner does not start	
No gas	Make sure all gas taps are open
No power	Check the fuse, thermostat and electrical connections
Burner motor does not start	Motor protection has tripped. Motor faulty.
Burner control faulty	Replace
Burner motor running, no ignition spark at the end of pre-aeration	
No power in the terminals	Check the connector. Replace faulty burner controls
Ignition electrodes in contact with each other or earth	Adjust
Ignition electrode porcelain damaged	Replace the electrodes
Poor connection to cable connectors	Adjust connection
Ignition cables damaged	Replace
Transformer damaged, no power to secondary winding	Replace the transformer
Ignition cable and ionisation cable swapped around	Reconnect
No flame propagation	
Gas solenoid valve faulty	Replace
Gas solenoid valve does not open despite having power	Replace solenoid valve terminals, or entire valve
No power to solenoid valve	Check the connection
No electrical connection through air pressure gauge	Check the air pressure gauge's settings and functions
Ignition load incorrectly set	Increase/decrease gas supply Reduce airflow

Cause of fault	Action
Burner control faulty	Replace
Air pressure gauge incorrectly set or faulty	Check the settings and reset, or replace
No acknowledgement signal due to incorrect adjustment or misalignment of the control motor cams.	Check the settings and realign.
Burner trips after safety time limit despite flame propagation	
No ionisation current or UV cell incorrectly positioned	Adjust ionisation electrode and UV cell Check cables and connectors
Burner control monitor faulty	Replace burner control
Voltage lower than 185 V	Contact an electrician
Ignition electrodes disrupting ionisation current	Adjust ignition electrodes. Re-polarise the transformer
Poor earth connection	Ensure adequate earth connection
Phase and neutral swapped around	Check wiring diagram and change accordingly
Burner trips during pre-aeration.	
Air sensor faulty or incorrectly set	Increase/decrease air setting. Reduce air volume
Ignition load incorrectly set	Increase/decrease gas supply Reduce airflow
Gas pressure too low	Increase pressure. If necessary, contact gas supplier
Pulsations at start-up	
Ignition electrodes incorrectly set	Adjust
Gas pressure too high	Check and adjust using pressure gauge and pressure control valve
Flue gas side blocked	Check the chimney flue
Burner pulsates during operation	
Burner incorrectly set	Adjust
Burner dirty	Clean the burner
Incorrect chimney	Check and modify dimensions if necessary
Burner functioning properly but with occasional blockage	
Ionisation current too low	Check. Must be at least 6 μ A, but should ideally lie between 8 and 20 μ A
UV cell incorrectly positioned	Adjust
Voltage drop at certain times	Must not drop below 15% of rated voltage. Contact an electrician if necessary
Incorrectly set or faulty air sensor	Check the settings and reset, or replace
Ignition electrode overload	Replace
Burner control ambient temperature too high	Insulate for heat, Max. 60 °
Ignition spark too weak	Check the transformer
Poor combustion	
Poor draught conditions	Check the chimney

Cause of fault	Action
Flue gas temperature too high	Boiler overloaded Decrease the gas volume, sweep the chimney if necessary
CO ₂ content too low	Choke the air supply. Check the boiler for any leakages. Choke the draught if too high
CO content too high	
Surplus air when using natural gas and liquefied petroleum (propane, butane)	Choke the air supply
Poor air supply	Open the air supply. Check flue gas damper
Holes in gas nozzle clogged.	Clean
Poor fresh air intake	Check and increase
Flame at incorrect angle due to combustion head out of position	Check the combustion head and readjust
Condensation build up in boiler and chimney	
Flue gas temperature too low or gas volume too low	Raise the flue gas temperature by increasing gas volume Insulate the chimney

EU Declaration of conformity

Bentone Gasburners



Certificate No.	Type	Certificate No.	Type
CE-0123CT1269	BFG 1	CE-0123CT1326	BG 550
CE-0123CT1270	STG 120	CE-0123CT1337	BG 600
CE-0123CT1281	STG 146	CE-0123CT1348	BG 650
CE-0123CT1292	BG 300	CE-0123CT1359	BG 700
CE-0123CT1304	BG 400	CE-0123CT1360	BG 800
CE-0123CT1315	BG 450	CE-0123CT1371	BG 950

This declaration of conformity is issued under the sole responsibility of the manufacturer. The object of the declaration described above is in conformity with:

Gas Appliance Regulation 2016/426/EU

Machinery Directive 2006/42/EC

EMC 2014/30/EU

Restriction of the use of certain hazardous substances (RoHS) Directive 2011/65/EU

References to the relevant harmonised standards used or references to the other technical specifications in relation to which conformity is declared:

EN 676+A2:2008

(excluded Annex J/K)

Automatic forced draught burners for gaseous fuels

Additional information can be downloaded at:

www.bentone.com

Enertech AB
Box 309
S-341 26 LJUNGBY

Ljungby February 15th, 2018

Håkan Lennartsson
Managing Director
Enertech AB

 **Bentone**[®]

13. General instructions for gasburners

13.4.1 Installation

1. Follow standards and instructions applicable to the installation of gas burners
2. Ensure that the electric installation is made in accordance with existing regulations
3. Check that the fresh air intake of the boiler room is sufficiently dimensioned
4. Check by studying the data plate that the efficiency of the burner is adapted to the boiler output
5. Check that the burner is adapted to the gas quality in question
6. Check that the input pressure of the gas is correct
7. Check that the dampers of the boiler are open
8. Check that there is water in the system
9. Check that thermostats etc. are correctly adjusted
10. Read the instructions and follow the directions given for the burner as to starting-up and service

13.4.2 Maintenance

General instructions

1. Keep the boiler room clean
2. Ensure that the fresh air intake of the boiler room is not restricted
3. Switch off the current and shut off the gas supply if the burner must be withdrawn from the boiler
4. Do not use the boiler for burning paper and waste if there is no special arrangement (fire room) for this

Normal operation

1. Ensure that the air supply to the burner is not obstructed by dust and dirt
2. Have the installer make a yearly overhaul of the installation so that safety is not jeopardized
3. Have the installer at the yearly overhaul also adjust the burner to ensure optimal combustion economy
4. Check periodically that there is water in the system (fill up if necessary) and that thermostats etc. are normally adjusted
5. Ensure that there is no water or dampness in contact with the burner

13.4.3 If the burner has stopped

1. Press the reset button of the relay
2. Check that the max. thermostat has not cut out
3. Check other thermostats for example room thermostat, if any
4. Check that the gas pressure to the burner is sufficient
5. Check that the electric fuses have not blown
6. Make a new attempt to start the burner and check the counter of the gas meter to find out whether the solenoid valve opens
7. If the burner does not start in spite of repeated starting attempts call the installer

13.4.4 Shut-Off

1. Switch off the current with the main switch
2. Shut-off the gas supply with the shut-off cock on the burner

13.4.5 Warning

1. Never keep your face in front of the fire room door when starting up the burner
2. Do not use naked flame when inspecting the fire room

Authorized installer::

Address:

Telephone:

Service- and inspection card

Installation		Boiler	
Name:		Type:	Efficiency kW:
Address:		Burner	
		Type:	Efficiency kW:
Installed by:		Date:	

Date	Nm ³ gas/h	Governor		CO ₂	CO	Fluegas temp	Ionisation current	Pressure		Efficiency
		Before	After					Fire room	Chimney	
Measu- rement				%	%	°C	µ A	mbar	mbar	%
	Small Flame									
	Large Flame									
	Measures									

Date	Nm ³ gas/h	Governor		CO ₂	CO	Fluegas temp	Ionisation current	Pressure		Efficiency
		Before	After					Fire room	Chimney	
Measu- rement				%	%	°C	µ A	mbar	mbar	%
	Small Flame									
	Large Flame									
	Measures									

Date	Nm ³ gas/h	Governor		CO ₂	CO	Fluegas temp	Ionisation current	Pressure		Efficiency
		Before	After					Fire room	Chimney	
Measu- rement				%	%	°C	µ A	mbar	mbar	%
	Small Flame									
	Large Flame									
	Measures									

