



Bentone BG 950

Reservdelar och tillbehör

Spare Parts and Accessories

Ersatzteile und Zubehör

Pièces détachées et accessoires



MADE IN SWEDEN

Innehåll - Index - Inhalt - Sommaire

1. Exteriör - Exterior - Exterieur - Extérieur _____	4
2. Förbränning - Combustion - Verbrennung - Combustion ____	5
3. Luftreglering - Air control - Luftsteuerung - Régularisation à air _____	6
4. Elkomponenter - Electric components - Elektrische Komponenten - Composants électriques__	7
5. Gaskomponenter - Gas components - Gaskomponenten - Composants de gaz _____	10
6. Bentone BG 950 LMV _____	13
7. Övrigt - Sundries - Verschiedenes - Divers _____	15

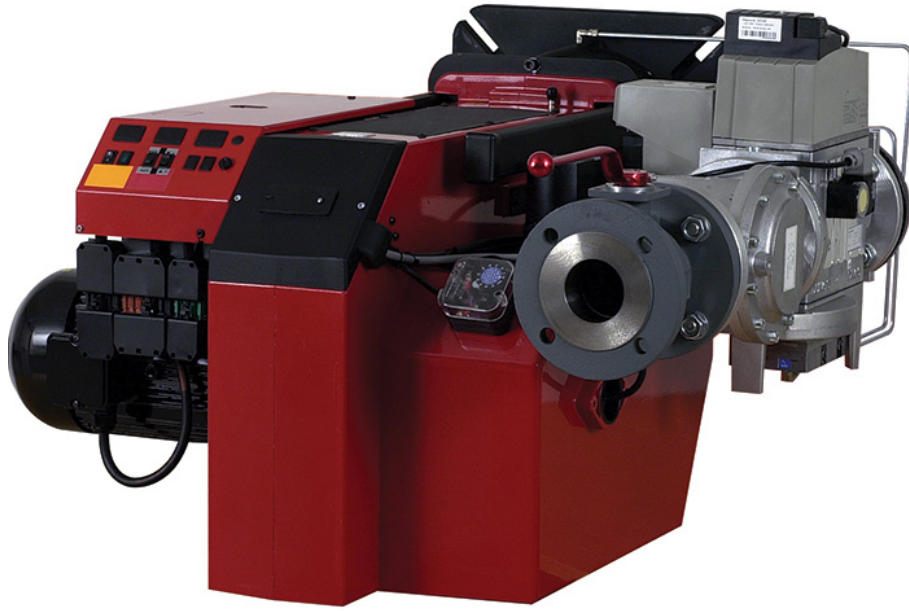

1. Exteriör - Exterior - Exterieur - Extérieur

Namn	Name	Name	Nom	Information	Artikel nr
1 Lock, fläkthus	Cover, fan housing	Deckel, Lüftergehäuse	Couvercle, carter de ventilateur		00119150005
3 Packning, lock	Gasket, cover	Dichtung, Deckel	Joint, couvercle		0011915101
5 Skyddsgaller	Grille	Gitter	Cage en filet		0011904801
7 Kåpa, inspektionsglas	Cover, inspection glass	Abdeckung, Inspektionsglas	Capot, Verre d'inspection		001190660105
9 Inspektionsglas	Inspection glass	Inspektionsglas	Verre d'inspection		0011808801
11 Packning, inspektionsglas	Gasket, inspection glass	Dichtung, Inspektionsglas	Joint, couvercle, verre d'inspection		0011795301
13 Lock, inspektionsglas	Cover, inspection glass	Deckel, Inspektionsglas	Couvercle, verre d'inspection		0011708001
15 Lock, fotomotstånd	Cover, photoresistor	Deckel, Fotowiderstand	Couvercle, cellule photorésistante		0011173101
17 Anslutningsfläns	Fixing flange	Anschlussflansch	Bride de fixation		001196521105
19 Gejder	Guide	Führungsschienen	Guides		001191420105
21 Konring, fläns	Cone ring, flange	Konusring, Flansch	Anneau cône, bride		0011961501
23 Packning	Gasket	Dichtung	Joint		0011278809
25 Packning, fläkthus-fläns	Gasket, fan housing-flange	Dichtung, brennergehäuse-flansch	Joint, carter du rotor-bride		0012134301

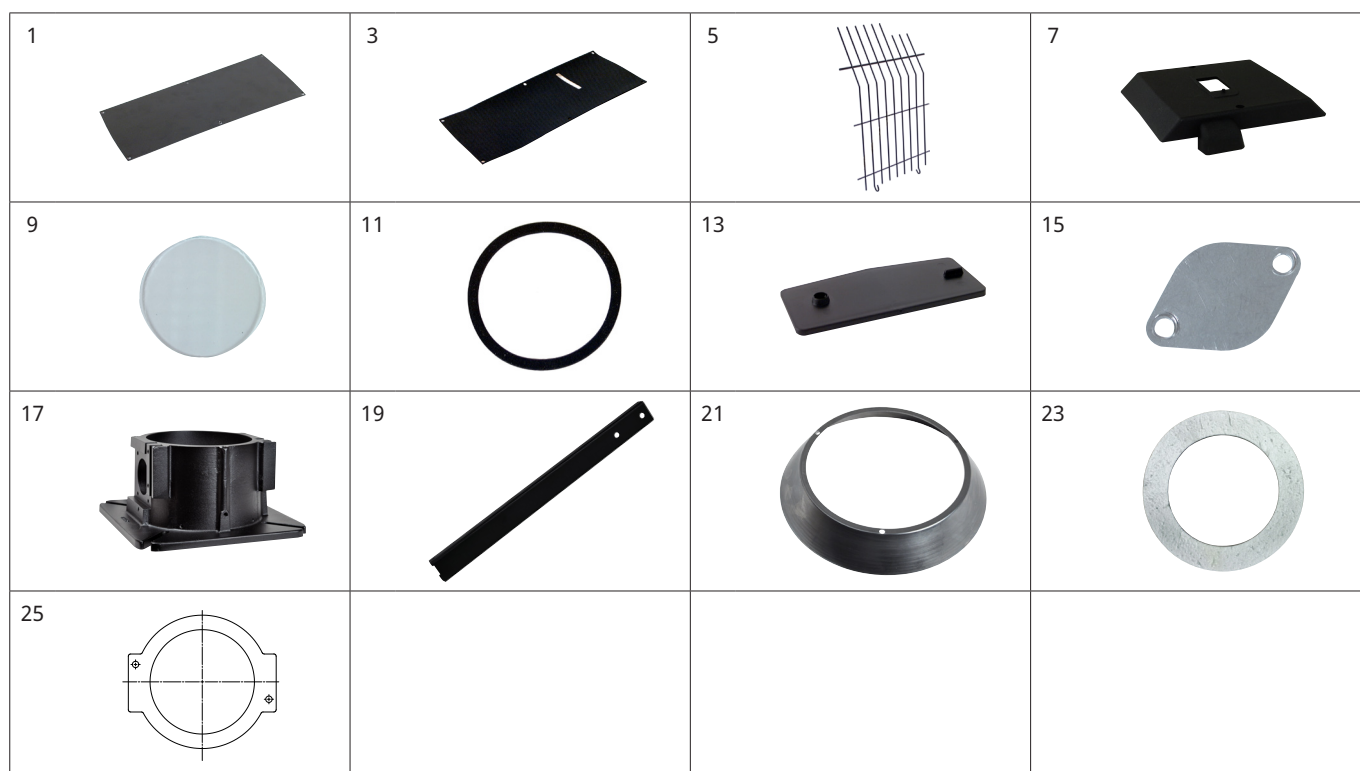

2. Förbränning - Combustion - Verbrennung - Combustion

Namn	Name	Name	Nom	Information	Artikel nr
1 Brännarrör	Flame tube	Brennerrohr	Tube de brûleur	L=350 mm	0012044601
3 O-ring	O-ring	O-ring	Joint torique	72,39 x 5,33	0011316850
5 Insats kompl.	Nozzle assembly compl.	Düsenstock, kompl.	Ligne porte-gicleur compl.		0011950210
7 Bromsskiva	Brake plate	Stauscheibe	Disque accroche-flamme	Ø 180 mm, till/to/zu/á: 2487918	0011473530
9 Bromsskiva	Brake plate	Stauscheibe	Disque accroche-flamme	Ø 180 mm, från/from/ab/de: 2487919	0092127931
11 Joniseringselektrod	Ionization electrode	Ionisationselektrode	Electrode d'ionisation		0091837301
13 Tändelektrod	Ignition electrode	Zündelektrode	Electrode d'allumage		0091865501
15 Joniseringskabel-sats	Ignition Cable Kit	Zündleitungssatz	Kit de fils d'allumage		0012026314
17 Tändkabelsats	Ignition Cable Kit	Zündleitungssatz	Kit de fils d'allumage		0012026304
19 Tänd/Joniseringskabel	Cable, Ignition/Ionozation	Kabel, Zünd/Ionisation	Câble, d'allumage/d'ionisation		0012074825

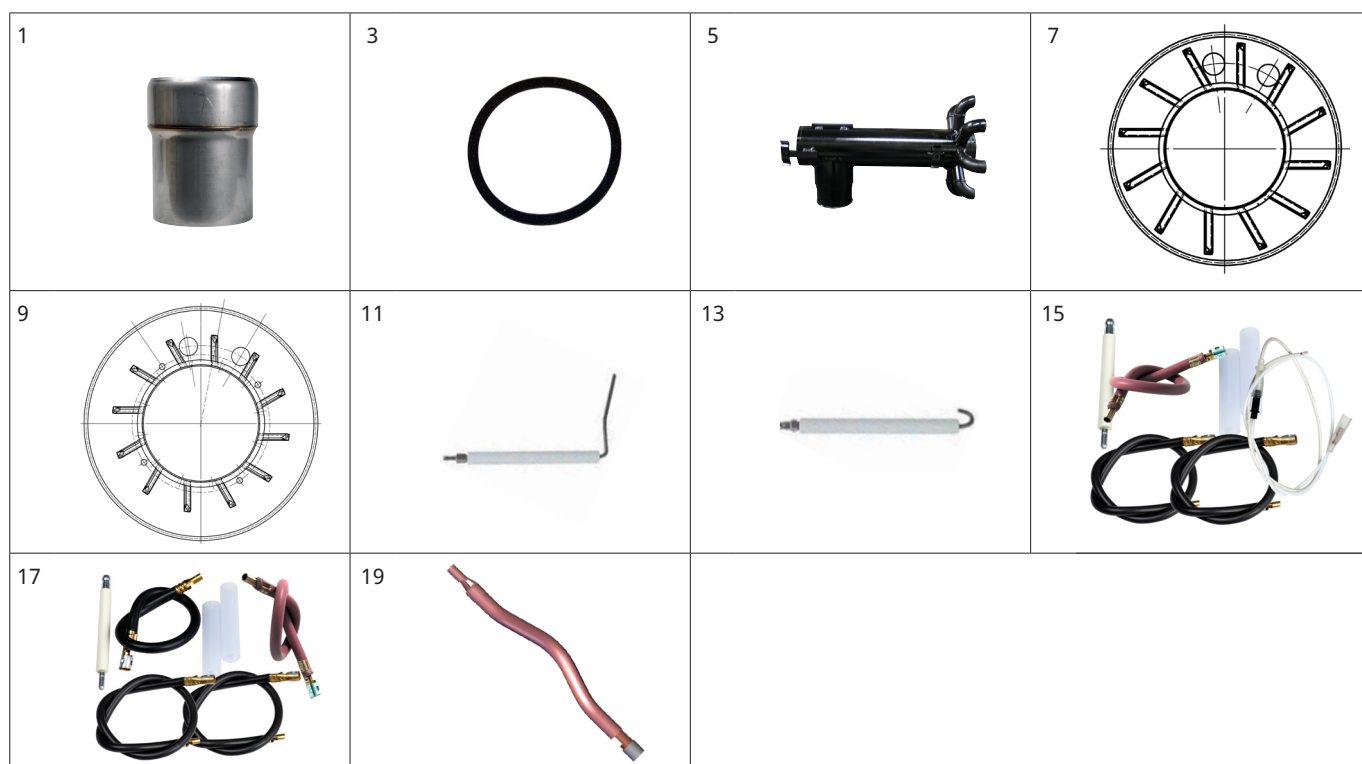

3. Luftreglering - Air control - Luftsteuerung - Régularisation à air

Namn	Name	Name	Nom	Information	Artikel nr
1 Luftspjäll	Air damper	Luftklappe	Volet d'air		0011946301
3 Spjällmotor	Damper motor	Klappenmotor	Moteur de volet	SQN 75	0011942305
5 Fästplatta, spjällmotor	Mounting plate Damper motor	Befestigungsplatte Stellmotor	Plaque d'attache, Servomoteur		001191490105
7 Pinnskruv, fästplatta	Stud screw, mounting plate	Stiftschraube, Befestigungsplatte	Vis à goupille, Plaque d'attache		0011920301
9 Länkmarm, spjällmotor	Stewing bracket, Damper motor	Gelenkarm, Stellmotor	Pivot, Servomoteur		0011947001
11 Mät nipple	Test nipple	Messnippel	Raccord de mesure	Ø8 x 1/8"	0012074501
13 Luft nippel, Tryckvakt	Air nipple, pressure Switch	Schlauchnippel, Druckschalter	Air mamelon, Pressostat		0011542301
15 Motor	Motor	Motor	Moteur	5,5/6,5 kW, 3F, 50/60Hz 230/400V	0012115501
17 Kabel motor	Motor cable	Motorkabel	Câble, moteur	4X2.5, L=750 mm	0011944902
19 Fläkthjul	Fan wheel	Gebbläserad	Rotor	290x114x28	0011277626
21 Avskärmningskon	Shielding cone	Abschirmkonus	cône défléchir		0011906201
23 Motorfläns	Motor flange	Motorflansch	Bride de moteur		001204210105



4. Elkomponenter - Electric components - Elektrische Komponenten - Composants électriques

Namn	Name	Name	Nom	Information	Artikel nr
1 Reläbox	Control box	Steuergerät	Boite de relais	L&G LFL 1.333E	0011463204
3 Styrautomat	Automatic control unit	Automatisches Steuergerät	Module de commande automatique	BP230UVFR-S2 B	0012122501
5 Reläsockel	Base, control box	Unterteil, Steuergerät	Socle de raccordement		0011463300
8 Flamdetektor	Flame detector	Flammendetektor	Détecteur de flamme	UV 5-2	0012122901
9 Fläns, flamdetektor	Flange, flame detector	Flansch, Flammendetektor	Bride, détecteur de flamme		0012126601
12 Kontaktor	Contacteur	Schütz	Contacteur	LC1D18P7S183	0012130802
12 Kontaktor	Contacteur	Schütz	Contacteur	LC1D25P7S183	0012130803
13 Motorskydd	Thermal overload protection	Überstromschutz	Déclencheur à maxima d'intensité	9,0-13,0 A	0012130908
13 Motorskydd	Thermal overload protection	Überstromschutz	Déclencheur à maxima d'intensité	16,0-24,0 A	0012130912
16 Transformator	Transformer	Transformator	Transformateur	FIDA	0011835301
17 Kabel, transformator	Cable, transformer	Kabel, Transformator	Câble, transformateur	FIDA, L=450mm	0011804701
18 Magnetventilkabel	Cable, solenoid valve	Kabel, Magnetventil	Câble, électrovanne	3 x 0,75, L=1200 mm.	0011951007
19 Kabel, gas tryckvakt	Cable, gas pressure switch	Kabel, gas-drückwächter	Câble, Pressostat à gaz	3 x 0,75 L = 1310 mm.	0011951106
22 Strömbrytare	Switch	Schalter	Interrupteur	0-1	0012132201

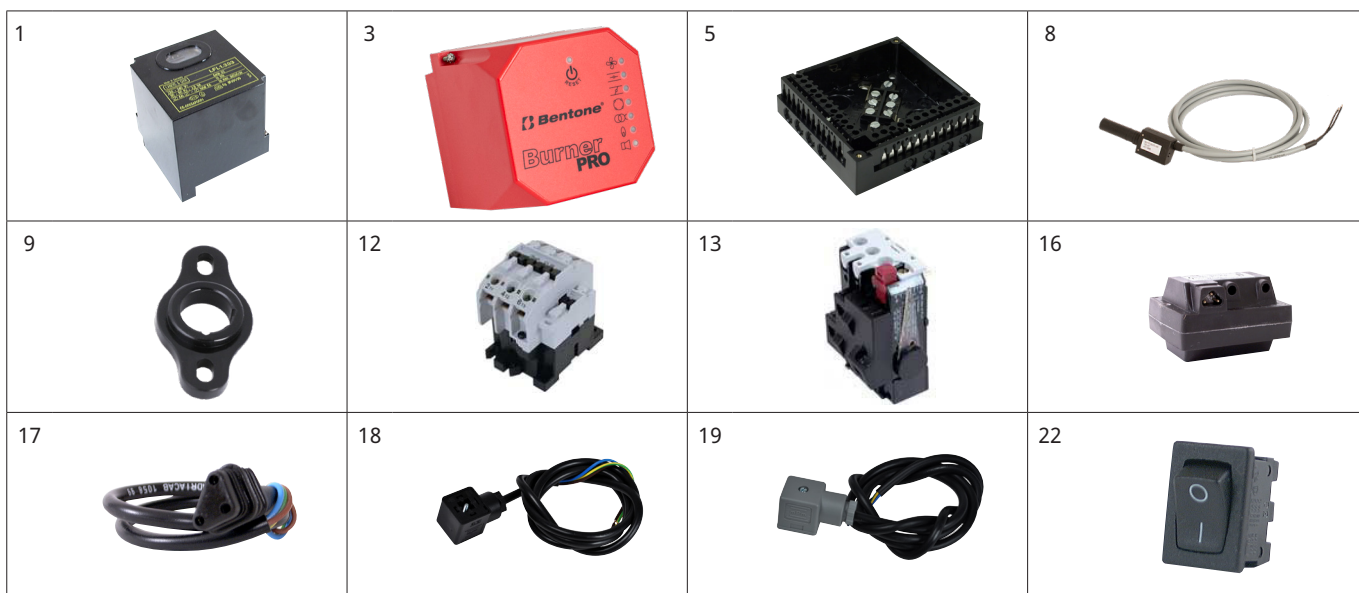

4. Elkomponenter - Electric components - Elektrische Komponenten - Composants électriques

Namn	Name	Name	Nom	Information	Artikel nr
23 Strömbrytare, Man-Aut	Power switch, man-aut	Hauptschalter, Man-Aut	Interrupteur d'alimentation, Man-Aut		0012132203
23 Omkopplare, öka-minska	Change-over switch, increase-decrease	Umschalter, erhöhen-reduzieren	Commutateur, augmenter-réduire		0011784302
25 Indikeringslampa, grön	Indication lamp, green	Anzeigelampe, grün	Voyant lumineux, vert		0011721103
27 Säkringshållare	Holder, fuse	Halter, Sicherung	Support, fusible		0011811803
28 Säkring	Fuse	Sicherung	Fusible	6.3 A	0011333201

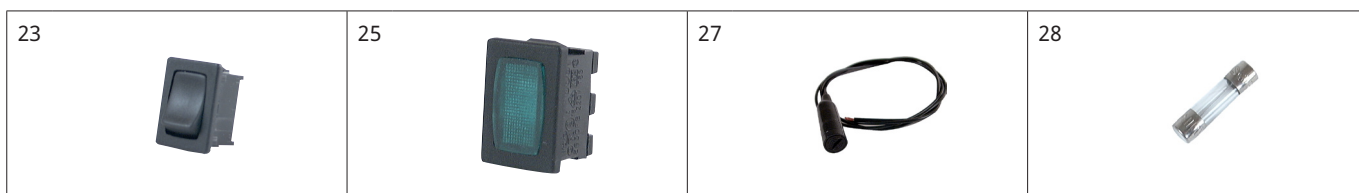

4. Elkomponenter - Electric components - Elektrische Komponenten - Composants électriques

Namn	Name	Name	Nom	Information	Artikel nr
30 Kontaktidon sats	Plug-in-contact set	Stecker Satz	Kit de conecteur	4 + 7 + 5	0011948613
31 Kontaktidon hona 4-polig, grön	Plug-in contact, female 4-pole, green	Buchsenteil 4-polig, grün	Prise "européenne" femelle 4-polaire, vert		0011919801
32 Kontaktidon 4-pol hane, grön	Plug-in contact, male 4-pole, green	Steckerteil 4-polig, grün	Prise "européenne" mâle 4-polaire, vert		0011919701
33 Kontaktidon hona 7-polig	Plug-in contact, female 7-pole	Buchsenteil 7-polig	Prise "européenne" femelle 7-polaire		0091558501
34 Kontaktidon 7-pol hane	Plug-in contact, male 7-pole	Steckerteil 7-polig	Prise "européenne" mâle 7-polaire		0011558500
35 Kontaktidon hona 5-polig	Plug-in contact, female 5-pole	Buchsenteil 5-polig	Prise "européenne" femelle 5-polaire		0011920001
36 Kontaktidon 5-pol hane	Plug-in contact, male 5-pole	Steckerteil 5-polig	Prise "européenne" mâle 5-polaire		0011919901
40 Kontaktidon sats	Plug-in-contact set	Stecker Satz	Kit de conecteur	Jumo, 4 + 7 + 5	0011948614
41 Kontaktidon hona 4-polig	Plug-in contact, female 4-pole	Buchsenteil 4-polig	Prise "européenne" femelle 4-polaire	Jumo	0011910401
42 Kontaktidon 4-pol hane	Plug-in contact, male 4-pole	Steckerteil 4-polig	Prise "européenne" mâle 4-polaire	Jumo	0011910301
45 Euro-kontakt, brännare extern reset (Tillbehör)	Plug-in contact, burner external reset (optional)	Eurostecker, Brenner Externe Rückstellung (optional)	Prise européenne, réarmement externe (en option), brûleur		0092062401

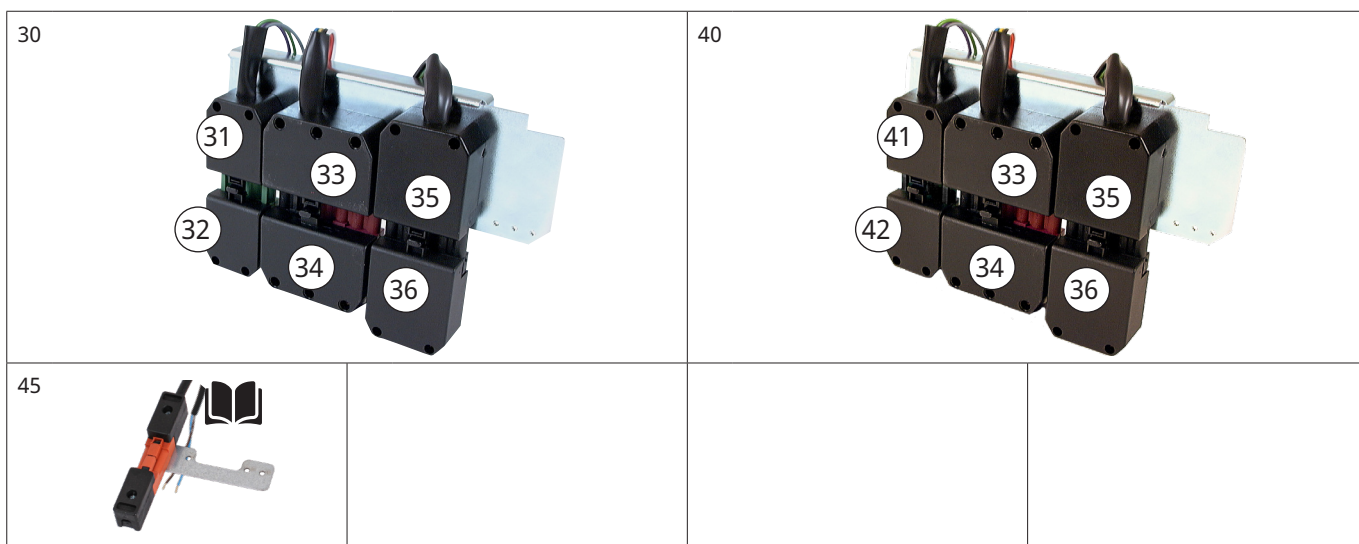

5. Gaskomponenter - Gas components - Gaskomponenten - Composants de gaz

Namn	Name	Name	Nom	Information	Artikel nr
1 Gasventil (MultiBloc)	Gas valve (MultiBloc)	Gasventil (MultiBloc)	Vanne de gaz (MultiBloc)	MBC 1900-VEF-65	0012050401
3 Gasventil (MultiBloc)	Gas valve (MultiBloc)	Gasventil (MultiBloc)	Vanne de gaz (MultiBloc)	MBC 3100-VEF-80	0012050501
5 Gasventil (MultiBloc)	Gas valve (MultiBloc)	Gasventil (MultiBloc)	Vanne de gaz (MultiBloc)	MBVEF 420	0011851139
7 Gasventil (MultiBloc)	Gas valve (MultiBloc)	Gasventil (MultiBloc)	Vanne de gaz (MultiBloc)	MBVEF 425	0011851137
9 Gasventil (MultiBloc)	Gas valve (MultiBloc)	Gasventil (MultiBloc)	Vanne de gaz (MultiBloc)	SET1.50 VDG20.5011	0012078501
11 Magnetventilsats, kontinuerlig fläkt	Solenoid Valve Kit, continuous fan	Magnetventil-Set, kontinuerliche Fan	Électrovanne Kit, ventilateur continue		0011923001
13 Fläns	Flange	Flansch	Bride	MB 415-20 1 ½"	0011899201
15 Fläns	Flange	Flansch	Bride	MB 415-20 2"	0011899202
15 Fläns	Flange	Flansch	Bride	MB 425 2"	0011899302
17 Impulsfläns	Impulse flange	Impulsflansch	Bride d'impulsions	MBVEF 420 D53	0011968404
19 Impulsfläns	Impulse flange	Impulsflansch	Bride d'impulsions	MBVEF 425 D55	0011968405
21 Spole	Coil	Spule	Bobine	MBVEF 420 1215	0011568824
21 Spole	Coil	Spule	Bobine	MBVEF 425 1405	0011568825











5. Gaskomponenter - Gas components - Gaskomponenten - Composants de gaz

Namn	Name	Name	Nom	Information	Artikel nr
25 Förbindelserör	Connecting pipe	Verbindungsrohr	Tube de liaison	2"	0011944401
25 Förbindelserör	Connecting pipe	Verbindungsrohr	Tube de liaison	DN 65	0011907320
25 Förbindelserör	Connecting pipe	Verbindungsrohr	Tube de liaison	DN 80	0011907020
28 Filtersats	Filter kit	Filter Kit	Kit de filtre	MB 415-420	0011916601
30 Gasfilter	Gas filter	Gas-Filter	Filtre gaz	GF520/1 2"	0011395416
32 Gasfilter	Gas filter	Gas-Filter	Filtre gaz	GF4006513 DN65	0011395417
32 Gasfilter	Gas filter	Gas-Filter	Filtre gaz	GF40080/3 DN80	0011395418
34 Mätning	Test nipple	Messnippel	Raccord de mesure	R 1/8	0011542701
36 Läckgaskontroll	Valve, leak tester	Dichtkontrolle	Contrôle d'étanchéité	VPS504 S02	0011861701
38 Tryckvakt	Pressure switch	Druckwächter	Pressostat	LGW50A2 2,5-50 MBAR	0011531907
38 Tryckvakt	Pressure switch	Druckwächter	Pressostat	GW50A5 5-50 MBAR	0011531926
38 Tryckvakt	Pressure switch	Druckwächter	Pressostat	GW150A5 10-150MBAR	0011531927
38 Tryckvakt	Pressure switch	Druckwächter	Pressostat	QPL15.150	0012079704
40 Kabel, luftvakt	Cable, air switch	Kabel, Luftwächter	Câble, pPressostat d'air	L=750 mm.	0011949703

25		28			
30		32		34	
36		38		40	



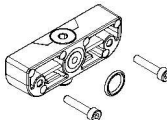



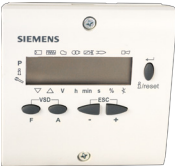

5. Gaskomponenter - Gas components - Gaskomponenten - Composants de gaz

Namn	Name	Name	Nom	Information	Artikel nr
42 Rörkoppling	Coupling	Kupplung	Raccord	1/8	0011545101
44 Vinkelkoppling	Elbow	Winkelkupplung	Coude	1/8	0011545201
46 Impulsrör	Impulse pipe	Impulsrohr	Tube d'impulsions	Ø6,0 x 1fz, 240 mm.	0011973811
46 Impulsrör	Impulse pipe	Impulsrohr	Tube d'impulsions	Ø6,0 x 1fz, 570 mm.	0011973812
46 Impulsrör, metervara	Impulse pipe, meter goods	Impulsrohr, meterware	Tube d'impulsions, merchandise de mètre	Ø6,0 x 1fz	0023107700
48 Planackning	Gasket	Flachdichtung	Joint	Ø 19/13*2	912375409
50 Planackning	Gasket	Flachdichtung	Joint	DN 65	0011524302
50 Planackning	Gasket	Flachdichtung	Joint	DN 80	0011524303
52 Kulventil	Ball valve	Kugelhahn	Vanne à boule	2"	0011396105
54 Kulventil	Ball valve	Kugelhahn	Vanne à boule	2 1/2"	0011524601
54 Kulventil	Ball valve	Kugelhahn	Vanne à boule	3"	0011524602
56 Adapter set	Adapter kit	Adapter Satz	Adapteur kit	GW Dungs	0012127101
58 Nippel	Nipple	Nipple	Raccord	1/4x1/4" KR	0005620502
60 Nippel	Nipple	Nipple	Raccord	2 x 2" FZ	0011463704

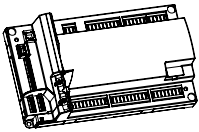
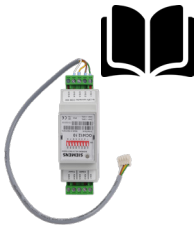
42		44		46			
48		50					
52		54		56		58	
60							

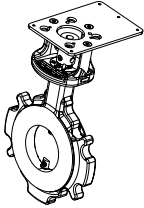
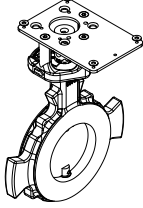





6. Bentone BG 950 LMV

Namn	Name	Name	Nom	Information	Artikel nr
1 Display	Display	Display	Afficheur	AZL.23	0012101101
3 Kabel, display	Cable, display	Kabel, Display	Câble, Afficheur	AZL.23, L= 186,4 mm	0012106301
5 Styrautomatik	Automatic control unit	Automatisches Steuergerät	Module de commande automatique	LMV37 ver. 4	0012101004
5 Styrautomatik	Automatic control unit	Automatisches Steuergerät	Module de commande automatique	LMV37 ver. 6	0012101006
6 Modbusenhet	Modbus unit	Modbusgerät	Unité Modbus		0092101901
7 Effektvakt	Power monitor	Leistungsüberwachung	Surveillance de puissance	QPL25 LMV	0012079714
11 Gasspjäll	Gas damper	Gasklappe	Amortisseur de gaz	VKF10.065	0012135001
12 Gasspjäll	Gas damper	Gasklappe	Amortisseur de gaz	VKF10.080	0012135002
13 Impulsrör, regulator	Impulse pipe	Impulsrohr	Tube d'impulsions	DN65-DN80, Ø6,0 x 1fz, 350 mm	0012104021
15 Nippel, impulsrör	Nipple	Nipple	Raccord	WE6-L Ø6x1/4"	0012105801
17 Nippel, impulsrör	Nipple	Nipple	Raccord	GE6-L/R 1/4	0011545102

1		3		5		6	
7				11		12	
13		15		17			

6. Bentone BG 950 LMV

Namn	Name	Name	Nom	Information	Artikel nr
19 Kontaktdon sats	Plug-in-contact set	Stecker Satz	Kit de conecteur	AGG3.132, X3-X75, LMV	0012106200
21 Kabel, magnetventil	Cable, solenoid valve	Kabel, Magnetventil	Câble, électrovanne	Hirshmann	0012106001
21 Kabel, gasvakt	Cable, gas guard	Kabel, gaswächter	Câble, garde de gaz	Hirshmann	0012106101
23 Kabel, lufttryckvakt	Cable, air pressure switch	Kabel, Luftdruckwächter	Câble, pressostat air		0012142505
25 Tätningring	Sealing ring	Dichtungsring.	Anneau d'étanchéité.	1/4"	0011983301
27 Spjällmotor, gas, med kabel	Damper motor, gas, with cable	Klappenmotor, gas, mit Kabel	Moteur de volet, gaz, avec câble	SQN13.170B9, 1800 mm.	0092101801
29 Spjällmotor	Damper motor	Klappenmotor	Moteur de volet	SQM33	0012101602

19		21		23		25	
27		29					

7. Övrigt - Sundries - Verschiedenes - Divers

Namn	Name	Name	Nom	Information	Artikel nr
20 Effektregulator	Power control	Leistungsregler	Régulateur de puissance	R316 T, PT 100	0012052601
20 Effektregulator, tryck	Power control, pressure	Leistungsregler, druck	Régulateur de puissance, pression	R316 T, 0-10V	0012052602
20 Effektregulator	Power control	Leistungsregler	Régulateur de puissance	R316 M, PT 100	0012052701
20 Effektregulator, tryck	Power control, pressure	Leistungsregler, druck	Régulateur de puissance, pression	R316 M, 0-10V	0012052702
24 Transformator	Transformer	Transformator	Transformateur	HDR-15-24 220 VAC/24 VDC	0012133901
25 Givare	Sensor	Fühler	Sonde	PT 100	0011581902
26 Jumo tryckgivare	Jumo pressure transmitter	Jumo Drucktransmitter	Jumo transmetteur de pression	0-1 bar	0011581905
26 Jumo tryckgivare	Jumo pressure transmitter	Jumo Drucktransmitter	Jumo transmetteur de pression	0-10 bar	0011581906
26 Jumo tryckgivare	Jumo pressure transmitter	Jumo Drucktransmitter	Jumo transmetteur de pression	0-16 bar	0011581907
29 Jumo termoelement	Jumo thermocouple	Jumo Thermoelement	Jumo thermocouple	-200 - 1500	0011581910
30 Jumo klämförskruvning termoelement	Jumo compression fitting thermocouple	Jumo, Klemmverschraubung für Thermoelemente	Jumo raccord à vis de serrage pour thermocouples		0011581911
35 Effektregulator, kapslad	Power regulator in device box	Leistungsregler im Gerätekasten	Régulateur de puissance dans la boîte de l'appareil	R316 T, PT 100	0012134901
35 Effektregulator, kapslad, tryck	Power regulator in device box, pressure	Leistungsregler im Gerätekasten, druck	Régulateur de puissance dans la boîte de l'appareil, pression	R316 T, 0-10V	0012134902
35 Effektregulator, kapslad	Power regulator in device box	Leistungsregler im Gerätekasten	Régulateur de puissance dans la boîte de l'appareil	R316 M, PT 100	0012134903
35 Effektregulator, kapslad, tryck	Power regulator in device box, pressure	Leistungsregler im Gerätekasten, druck	Régulateur de puissance dans la boîte de l'appareil, pression	R316 M, 0-10V	0012134904

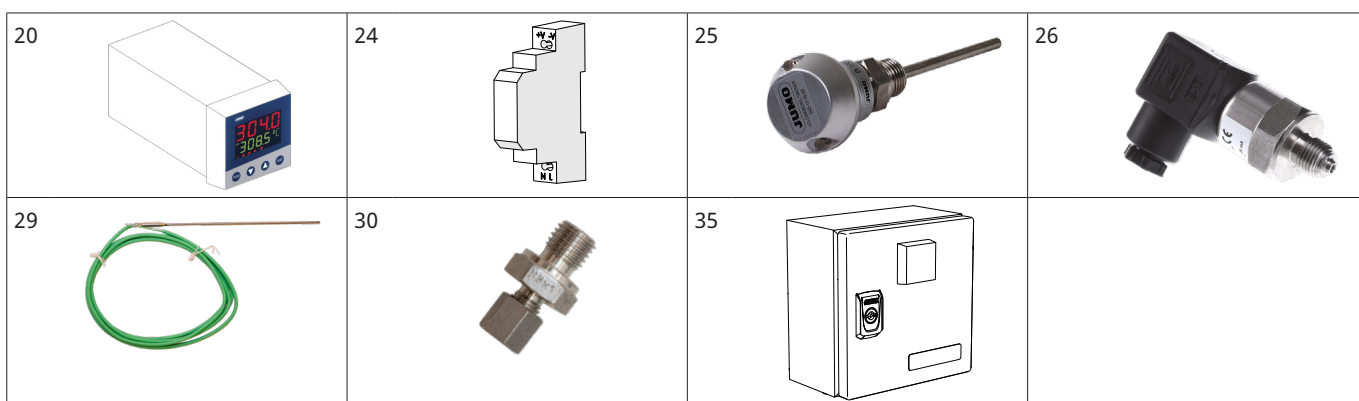



CTC AB Box 309 SE-341 26 Ljungby

info@bentone.se +46 372 88 000

www.bentone.se