



Providing sustainable energy solutions worldwide

Installation- and maintenance instruction

**BG 450 M**

LME22.233C2

MB-VEF 412

RT



**-sv**

### 1. Manualer på övriga språk

2. [www.bentone.com\download](http://www.bentone.com/download) eller scanna QR-koden.

3. Skriv in brännarens artikelnummer som finns på din typskylt (se bild) och välj ditt språk.

Detaljerad ecodesign information kan laddas ner på:  
[www.bentone.com/ecodesign](http://www.bentone.com/ecodesign).

**-fr**

### 1. Manuels dans d'autres langues

2. [www.bentone.com\download](http://www.bentone.com/download) ou scannez le code QR.

3. Saisir le numéro d'article du brûleur sur votre plaque signalétique (consultez l'illustration) et sélectionnez la langue.

Des informations détaillées sur l'ecodesign peuvent être téléchargées à l'adresse:  
[www.bentone.com/ecodesign](http://www.bentone.com/ecodesign).



**-en**

### 1. Manuals in other languages

2. [www.bentone.com\download](http://www.bentone.com/download) or scan QR-code.

3. Enter the burner's article number on your data plate (see picture) and select language.

Detailed ecodesign information can be downloaded at:  
[www.bentone.com/ecodesign](http://www.bentone.com/ecodesign).

**-de**



### 1. Gebrauchsanweisungen in anderen Sprachen

2. [www.bentone.com\download](http://www.bentone.com/download) oder scannen Sie den QR-Code.

3. Geben Sie die Artikelnummer des Brenners auf Ihrem Typenschild ein, (siehe Bild) und wählen Sie die Sprache aus.

Detaillierte Informationen zum Ecodesign können unter [www.bentone.com/ecodesign](http://www.bentone.com/ecodesign) heruntergeladen werden.

### 3. exempel example Beispiel

352011030141	Serial no. 1234567	Man.Year 2019
Designation	BF 1 KS 76-24	
Type	BF 1	
Model	BF 1 KS 76-24	
Cap. Min-Max	LIGHT OIL 35-90KW 1,25-6,0 cSt 7-14bar	
Main supply	1-230V 1,0A 50Hz IP 20	
Motor supply		
MADE IN SWEDEN BY		

**-da**

### 1. Manualer på andre sprog

2. [www.bentone.com\download](http://www.bentone.com/download) eller scan QR-koden.

3. Indtast brænderens artikelnummer, der findes på typeskiltet (se billede), og vælg dit sprog.

Detaljerede oplysninger om ecodesign kan downloades på:  
[www.bentone.com/ecodesign](http://www.bentone.com/ecodesign).

# Table of contents

<b>1. General Information</b>	<b>4</b>	<b>6. Multibloc MB-VEF 407-412</b>	<b>23</b>
<b>2. Technical data</b>	<b>7</b>	6.1 Recommended excess air when using default setting	26
2.1 Dimensions	7	6.2 Determining the gas quantity for the system	26
2.2 Capacity range	8	6.3 Calculating the quantity of gas supplied	28
2.3 Appliance categories	8	<b>7. Service</b>	<b>29</b>
2.4 Working field BG 450-2, BG 450 M	9	7.1 Servicing the combustion assembly	29
2.5 Electric Specification EN 60335-2-102	9	7.2 Servicing air dampers	30
2.6 Description	10	7.3 Replacement of damper motor, air	31
<b>3. General instructions</b>	<b>11</b>	7.4 Vibration	32
3.1 General instructions	11	7.5 Flame monitoring and ionisation current check	33
3.2 Installation and maintenance instructions	11	<b>8. Handing over of the installation</b>	<b>35</b>
3.3 Instructions	11	<b>9. Fault location, functional troubles</b>	<b>35</b>
3.4 Inspection and maintenance	11	<b>10. Electric equipment</b>	<b>36</b>
3.5 Start up	11	10.1 Safety system	36
3.6 Commissioning of installation	11	10.2 Wiring diagram LME	37
<b>4. Installation</b>	<b>12</b>	10.3 Function LME...	38
4.1 Delivery check	12	10.4 Control program at faults; fault mode indicator LME ....	39
4.2 Preparations for installation	12	<b>11. Troubleshooting</b>	<b>41</b>
4.3 Gas supply	12	<b>12. General instructions for gasburners</b>	<b>44</b>
4.4 Electric connection	12		
4.5 Setting brake plate and air flow	12		
4.6 Handling and lifting instruction	13		
4.7 Mounting on the boiler	14		
4.8 Inspection of gas nozzle before commissioning	15		
4.9 Leakage control	16		
4.10 Gas nozzle	17		
4.11 Setting Damper motor, modulating operation	18		
<b>5. Setting the burner</b>	<b>19</b>		
5.1 Setting the combustion assembly	19		
5.2 Setting the air pressure switch	20		
5.3 Setting the min. gas pressure switch	21		
5.4 Skeleton diagrams	22		

# 1. General Information

This Installation and Maintenance manual:

- is to be regarded as part of the burner and must always be kept near the installation site.
- is intended for use by authorised personnel.
- must be read prior to installation.
- must be observed by all who work with the burner and associated system components.
- work with the burner may only be carried out by certified installers/ personnel.

Enertech AB is not liable for any typographical errors and reserves the right to make design changes without prior notice.

## Safety instructions

- The burner may only be used for its intended purpose in accordance with the product's technical data.
- The burner may only be installed and operated by authorised personnel.
- The product is packaged to prevent damage from occurring during handling. Handle the product with care. Lifting equipment must be used to lift larger packages.
- The products must be transported/stored on a level surface in a dry environment, max. 80% relative humidity, no condensation. Temperature -20 to +60 °C.
- Check that the burner is compatible with the boiler's output range.
- All components must be installed without being bent, twisted or subjected to mechanical or thermal forces which can affect the components.
- The burner must be installed so that it complies with local regulations for fire safety, electrical safety, and fuel distribution.
- The gas outlet from the pressure regulator shall be configured in accordance with applicable regulations and lead to a safe area.
- Make sure when installing the equipment that there is enough space to service the burner.
- Permitted temperature during operation -10 to +60 °C. Max 80% relative humidity, no condensation.
- The installer must ensure that the room has adequate air supply.
- The room must comply with local regulations pertaining to its intended use.
- The installation site must be free of chemicals.
- Burner pipes, fan wheels and air dampers may contain sharp edges.
- The surface temperature of the burner's components can exceed 60 °C.
- Caution: The burner has moving parts, and there is risk of crushing injuries.



- The electrical installation must be professionally carried out in accordance with applicable high voltage regulations, as per Enertech's recommendations.
- Before servicing, shut off the fuel supply and turn off the power to the burner.
- Seal inspections must be performed during installation and servicing to prevent gas leakage.
- Care should be taken by the installer to ensure that no electrical cables or fuel lines are crushed or otherwise damaged during installation or servicing.
- If the boiler is equipped with an access hatch, this must be equipped with a hatch opening switch connected to the burner's safety system.
- When in operation, the burner's noise level can exceed 85 dBA. Use hearing protection.
- The burner must not be put into operation without proper safety and protection devices.
- A Class BE fire extinguisher is recommended.
- It is forbidden to alter the design or use accessories which have not been approved by Enertech in writing.
- Prior to operation, the following points must be checked:
  - fitting and installation work has been completed and approved
  - electrical installation has been correctly performed
  - flue gas ducts and combustion air ducts are not blocked
  - all actuators and control and safety devices are in working order and correctly set



## Actions to take if you smell gas

Turn off the equipment and the boiler. Open windows and doors. Prevent open flames or sparking, e.g. do not turn lights on or off, do not use any electrical appliances, do not use mobile phones. Open windows and doors. Close the gas ball valve. Warn residents; do not use doorbells. Evacuate the building. Notify the installer or gas supplier once the building has been evacuated.

## Burner servicing schedule

Servicing must be carried out once a year or after 3 000 hours of operation.

Burner	1 year	3 000 hrs
Inspection of electrical installation	1 year	3 000 hrs
Leakage check	1 year	3 000 hrs
Filter	1 year replacement at $\Delta p > 10$ mbar	3 000 hrs replacement at $\Delta p > 10$ mbar
Electrodes	Replacement/Cleaning 1 year	Replacement/Cleaning 3 000 hrs
Brake disc	Replacement/Cleaning 1 year	Replacement/Cleaning 3 000 hrs
Motor	1 year	3 000 hrs
Fan wheel	1 Year Replacement when cleaning needed/imbalance	3 000 hrs Replacement when cleaning needed/imbalance

## Component replacement intervals

Control system	10 years	250 000 starts
Valve control system	10 years	250 000 starts
Pressure switch	10 years	250 000 starts
Ignition system with flame guard	10 years	250 000 starts
UV flame sensor	10 000 hrs	N/A
Gas pressure regulators	15 years	N/A
Gas valve without seal testing	10 years	250 000 starts
Gas valve with seal testing	Replacement upon fault detection	N/A
Gas pressure switch	10 years	250 000 starts
Safety blow-off system	10 years	N/A
Damper motor	N/A	500 000 starts
Contactors	10 years	500 000 starts



The burner and its components must be recycled according to applicable regulations.

## Delivery check

- Make sure everything is delivered and the goods have not been damaged during transit.
- If something is wrong with a delivery, report it to the supplier.
- Transport damage must be reported to the shipping company.

## 2. Technical data

Burners are intended for use at:

- Water heating generators.

### 2.1 Dimensions

- Connection 1-2".

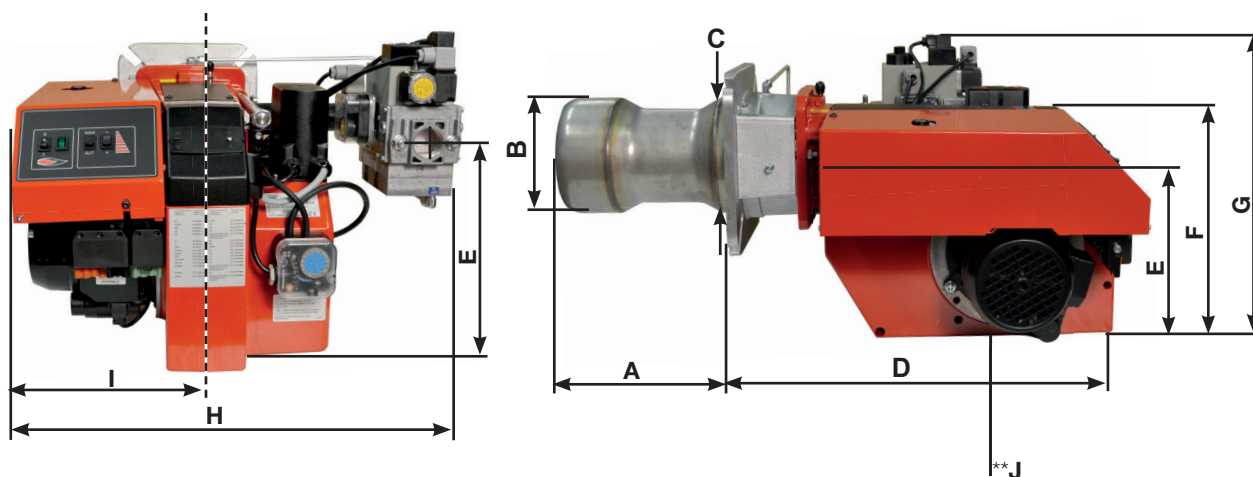

Type		Length of burner tube	Flange measure A	Burner tube measure B	Burner tube measure C
<b>BG 450</b>	1	256	226	∅160	∅162
	2	356	326	∅160	∅162
	3	456	426	∅160	∅162

	D	E	F	G	H	I	**J
<b>BG 450</b>	538	252	328	*500	*640	262	200

\* The above dimensions are max. measurements. Depending on the components used, the measurements may vary.

\*\* Min. recommended distance to floor.

#### 2.1.1 Heat generator connection dimensions

	K	L	M
<b>BG 450</b>	M12	(∅ 210) ∅ 255-290	∅ 170

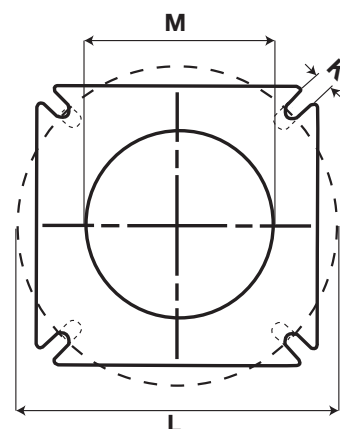

172.515.28-2 2021-04-16

## 2.2 Capacity range

Capacity kW	Gas quantity at min. power Nm <sup>3</sup> /h <sup>1)</sup>	Gas quantity at max. power Nm <sup>3</sup> /h <sup>1)</sup>	Max. connection pressure mbar	Min connection pressure mbar
<b>BG 450</b>				
G20 120-550	12,6	57,9	360	see data plate
G25 120-550	14,6	67,1	360	
G30 120-550	3,7	16,9	360	
G31 120-550	4,9	22,4	360	

<sup>1)</sup> Lower heat value Hu at normal state 15°C and 1013.25 mbar EN676

Grade of gas		kWh/Nm <sup>3</sup>	MJ/Nm <sup>3</sup>	kcal/Nm <sup>3</sup>
Natural gas	G20	9.5	34.02	8126
Natural gas	G25	8.2	29.25	6986
Butane	G30	32.5	116.09	27728
Propane	G31	24.6	88.00	21019
Biogas		6,0	21,60	5159

Gas quantity and capacity vary according to grade of gas and connection pressure.

## 2.3 Appliance categories

Only dry gas is permitted for use.

Category	Country of destination	Supply pressure
II <sub>2R3R</sub>	AT, BE, BG, CH, CY, CZ, DE, DK, EE, ES, FI, FR, GB, GR, HR, HU, IE IS, IT, LT, LU, LV, MK, MT, NL, NO, PL, PT, RO, RS, SE, SI, SK, TR	20 mbar
II <sub>2H3B/P</sub>	AT, CH, CY, DK, FI, LT, RO, SE, SK	20 mbar
II <sub>2H3P</sub>	GB, IE	20 mbar
II <sub>2L3B/P</sub>	NL, RO	20 mbar
II <sub>2E3B/P</sub>	PL	20 mbar
I <sub>2E(R)B</sub>	BE	20 mbar
I <sub>3P</sub>	BE	20 mbar

160302-239-2



## 2.4 Working field BG 450-2, BG 450 M

120-550 kW

mbar

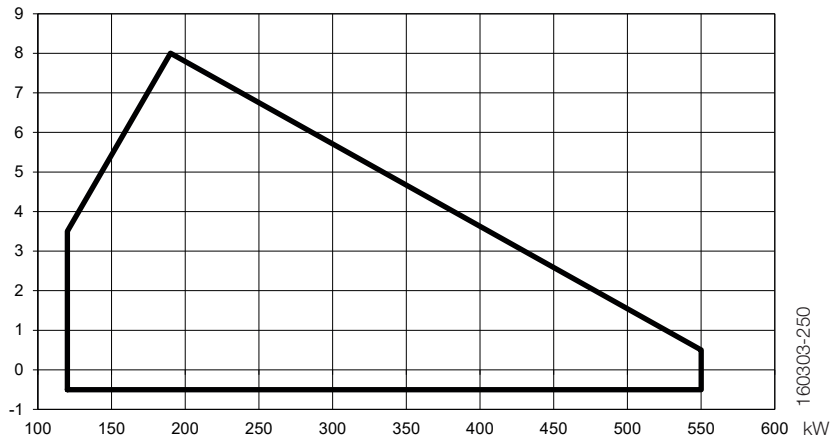

**!** Do not exceed working field.

## 2.5 Electric Specification EN 60335-2-102

Burner correspond to IP20

Type	BG 450
Motor	450W 230V 3,3A 50Hz
The recommended main fuse motor	C10A
Fitting	Naturgas, Propan, Butan 1 1/2"-2"
Control power	230V 3,3A 50Hz
Sound	89 dBA ± 0,5 dBA

Measurements according to EN 3746: 2010

Alt.1 The sound level of the burner can be reduced by equipping the burner with silencer. Installation must be done so it does not prevent air supply to the burner.

Alt.2 The burner's noise level can be reduced by connecting the burner's air intake to the air duct that opens into an appropriate location. Installation must be done so it does not prevent air supply to the burner.

## 2.6 Description

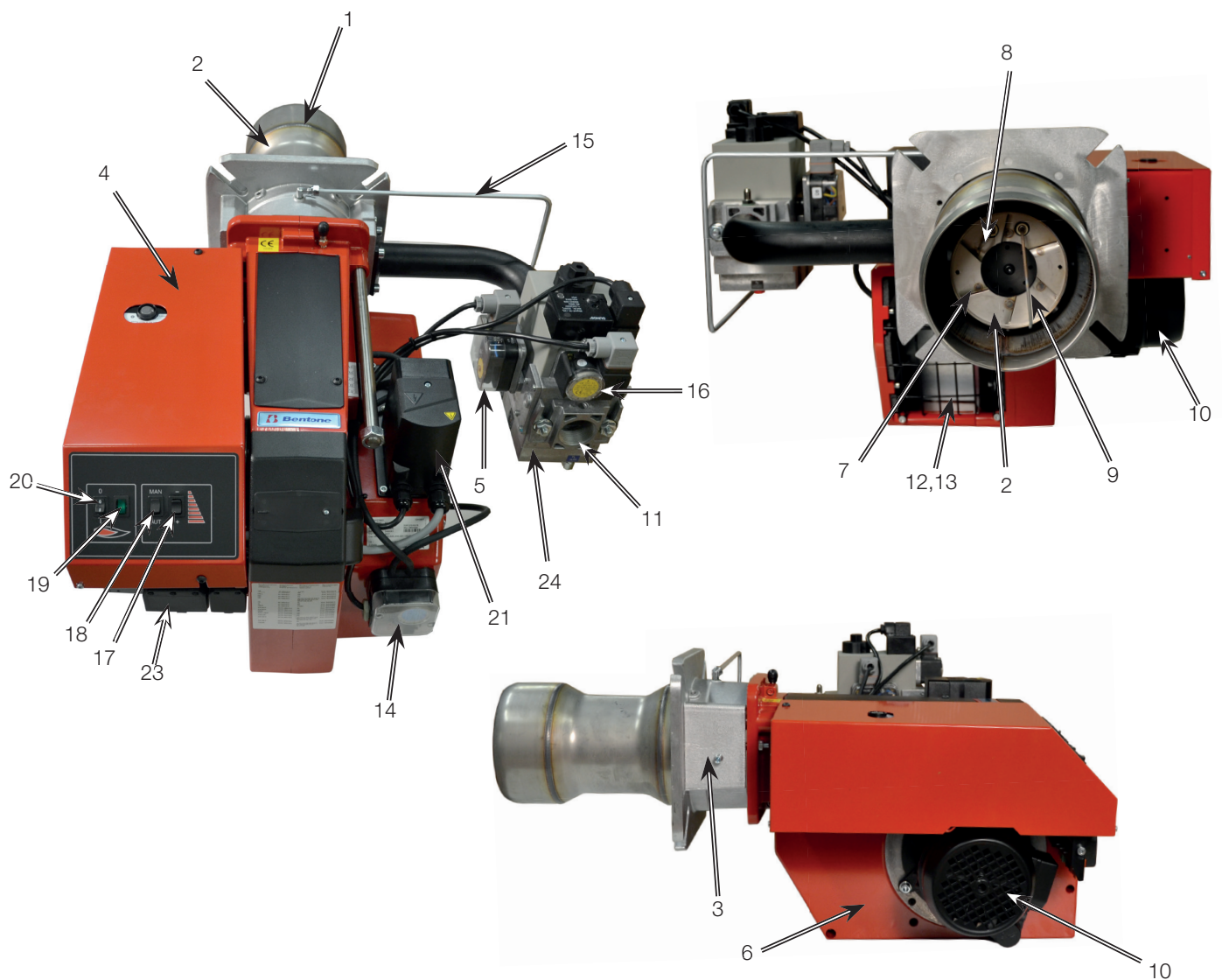

### Components

- |                             |  |                               |
|-----------------------------|--|-------------------------------|
| 1. Burner tube              | 11. Gas connection                       | 19. Indicator lamp, operation |
| 2. Nozzle assembly          | 12. Air intake                           | 20. Switch 0-1                |
| 3. Connection flange        | 13. Air damper                           | 21. Damper motor              |
| 4. Electrical panel         | 14. Air pressure switch                  | 22. Relay box                 |
| 5. Max. gas pressure switch | 15. Impulse pipe                         | 23. Electrical connection     |
| 6. Fan housing              | 16. Gas pressure switch                  | 24. MultiBloc                 |
| 7. Brake plate              | 17. Changeover switch, increase-decrease |                               |
| 8. Ignition electrode       | 18. Changeover switch, manual-automatic  |                               |
| 9. Ionisation electrode     |  |                               |
| 10. Motor                   |  |                               |

## 3. General instructions

### 3.1 General instructions

The installation of the gas burner must be carried out in accordance with current regulations and standards. The installers of gas burners should therefore be acquainted with all regulations and ensure that the installation complies with the requirements. The installation, mounting and adjustment should be made with the greatest care and only the correct gas should be used.

### 3.2 Installation and maintenance instructions

The maintenance instructions supplied with the burner must be kept at an easily accessible location in the boiler room.

### 3.3 Instructions

The user should be thoroughly instructed in the function of the gas burner and the whole installation. The supplier must instruct the user.

### 3.4 Inspection and maintenance

The unit must be serviced and maintained at the interval specified in the service schedule. If the burner is in a dirty environment, service should be done at more frequent intervals than specified.

### 3.5 Start up

After the burner has been fitted to the boiler and the electric connection, the leakage control, the venting and the electric function test have been carried out, the burner will be ready for start-up.

However, study the sections dealing with adjustments of multi-bloc, combustion air and combustion head. Open the ball valve and switch on the main switch. If the burner starts the actual adjustment can be made.

### 3.6 Commissioning of installation

Control of the combustion. The combustion quality is checked by means of a flue gas analysis device. Adjust the burner to appr. 20% excess air in accordance with the table. Check the flue gas temperature. Calculate the efficiency. Check also the actual gas volume on the gas meter so that the correct input is achieved.

## 4. Installation

### 4.1 Delivery check

Check that all has been delivered and that the goods have not been damaged during transport. If that is not the case, please notify the delivery company. Transport damages should be reported to the forwarding agency.

### 4.2 Preparations for installation

Check that the measurements and capacity range of the burner are compatible with the boiler. The power ratings on the type plate refer to the min. and max. power of the burner.

### 4.3 Gas supply

For good operating safety, it is important that the gas supply system is installed correctly.

Consider the following:

1. Check that the burner is approved for the gas quality of the installation. If not, please contact the supplier.
2. Check that the gas components of the burner are approved for indicated gas pressure.
3. The gas supply system should be installed in accordance with current standards.
4. Pipe lines should be run so that service on boiler and burner is facilitated.
5. Pipe lines should be run so that eventual contaminants cannot come into contact with the gas components.
6. Gas discharge system must be installed prior to local regulations.

### 4.4 Electric connection

Before starting the electric installation, the main switch must be turned off. If the boiler has a 7-pole and a 4-pole Eurostecker connector, these usually fit directly to the burner. If not, use the connectors included, (see connection under Electric equipment).

### 4.5 Setting brake plate and air flow

Before the placing into service, the burner should be initially set according to diagram, (see Basic settings). Note that it is only a basic setting which should be adjusted once the burner has been started.



If an electric connection other than the one recommended by Enertech is used, a risk of damage and injury can arise.

# 4.6 Handling and lifting instruction

## 4.6.1 BG 450



**!** The lifting aids we use here are available as accessory.



## 4.7 Mounting on the boiler

Mount the burner to the boiler using 4 bolts. See technical data for the hole pattern.

To make the fitting process easier, it is possible to separate the burner body from the gas flange with the combustion head and valve assembly in place.

Proceed as follows:

1. Ensure that no power is going to the burner. Break the main current and disconnect the Euro plugs from the burner. NB: If the burner is directly connected, ensure that all components on the burner are without power.
2. Remove the cover plate from the fan housing.
3. Loosen screw D on the nozzle assembly.
4. Disconnect the electrical cables to the valve assembly and gas damper motor.
5. Undo the screws (B) on both sides.
6. Undo the end stops (C) on the guides.
7. Disconnect the ignition cable, ionisation cable, and control arm from the gas nozzle.
8. Pull out the burner body from the guides and put it in a suitable place.

After separating the burner body and the gas flange, it is easier to mount the gas flange with the burner head and valve assembly to the boiler (loosen the valve assembly if required). Once the gas flange is fitted to the boiler, it is easy to lift the burner body up onto the guides. Assemble the burner in reverse order to its disassembly.



Check the gas tightness.

Service position

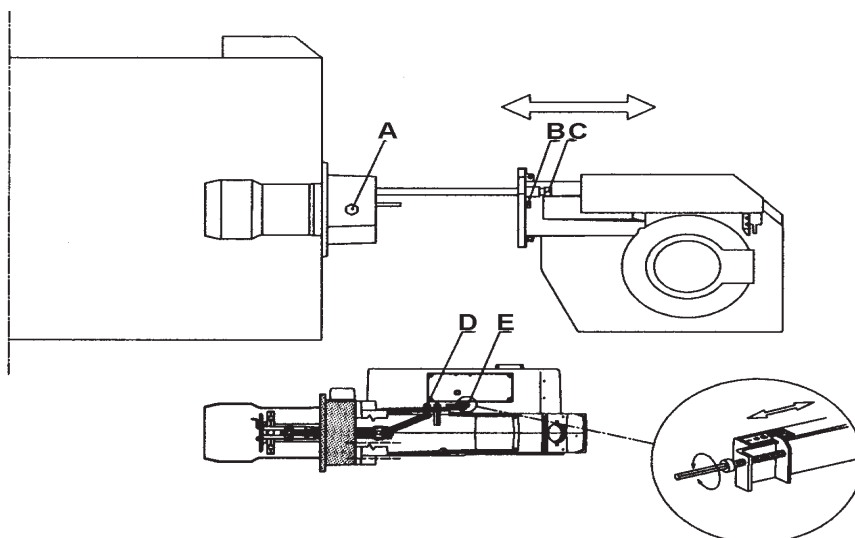

## 4.8 Inspection of gas nozzle before commissioning

The gas nozzle can easily be inspected by using the guides on the burner.

Proceed as follows:

1. Ensure that no power is going to the burner. Switch off the main power supply and disconnect the Euro plugs from the burner.



If the burner is directly connected, ensure that all components on the burner are without power.

2. Remove the cover plate from the fan housing.
3. Undo the nut (D) to the nozzle assembly.
4. Disconnect the ignition cable and ionisation cable for the gas nozzle.
5. Ensure there is enough slack in the electrical cables to the valve assembly and gas damper motor to pull out the burner body in the rear position on the guides. If there is not enough slack the cables can be disconnected.
6. Undo the screw (B) on both sides.
7. Pull out the burner on the guides.
8. Undo the screw(s) (A) on the gas flange.
9. Take out the gas nozzle.
10. See section Gas nozzle

Re-assemble the burner in reverse order to that described above. When re-assembling, make sure that the O-ring located between the gas nozzle and the gas flange is in the correct position when the nozzle is re-fitted.

Service position

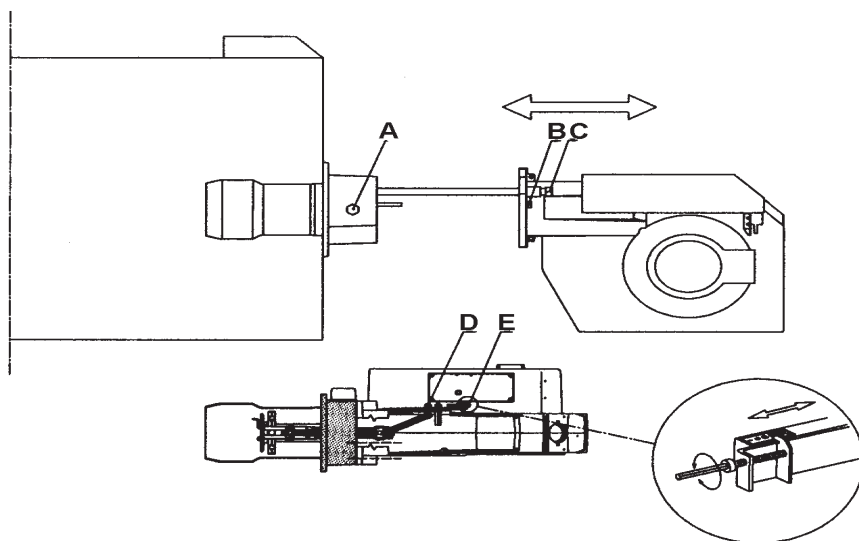

## 4.9 Leakage control

When making a leakage control of the gas supply system the solenoid valve should be closed. Connect a pressure gauge to the test nipple Pa, see fig. The test pressure in the system should be 1,5x max. inlet pressure or min. 150 mbar. If any leakage, locate the source by means of soapy water or a leak location spray. After tightening repeat the test.

### Electric function test:

Ensure that phase and neutral are not reversed. The gas shut-off cock should be closed. To prevent the gas pressure switch from locking out it should be linked temporarily.

After the main switch has been switched on and the thermostats have been adjusted the pre-purging period begins (30-35sec.). At the end of this period the pre-ignition period starts (0,5-2,5 sec. dependent on the design of the gas control). The gas valve is energized and opens and flame is established. At the end of the safety time (2-3 sec.) the gas control locks out. The solenoid valve and the motor will be "dead". Remove the link from the gas pressure switch after the test is finished.

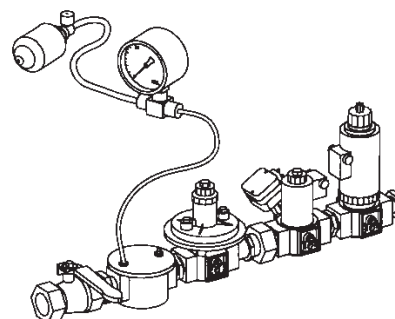
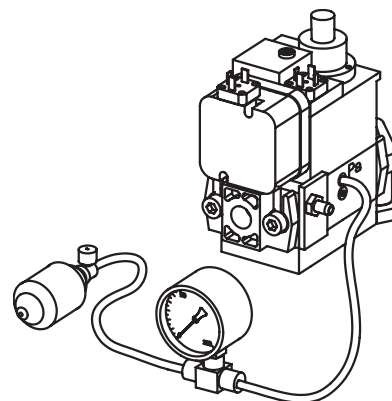



## 4.10 Gas nozzle

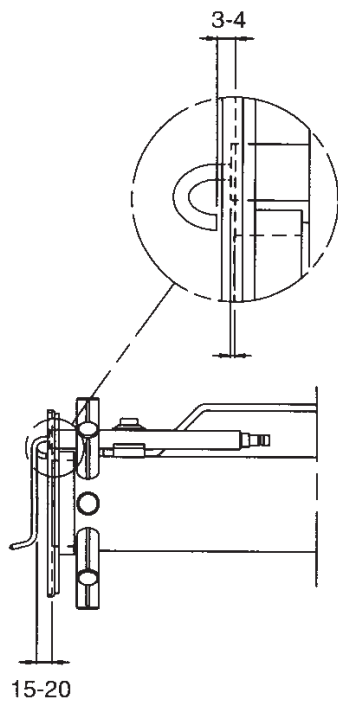

Natural gas

Propan

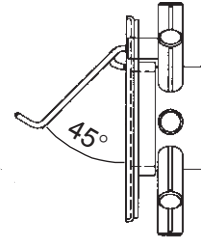

Biogas (UV detector)

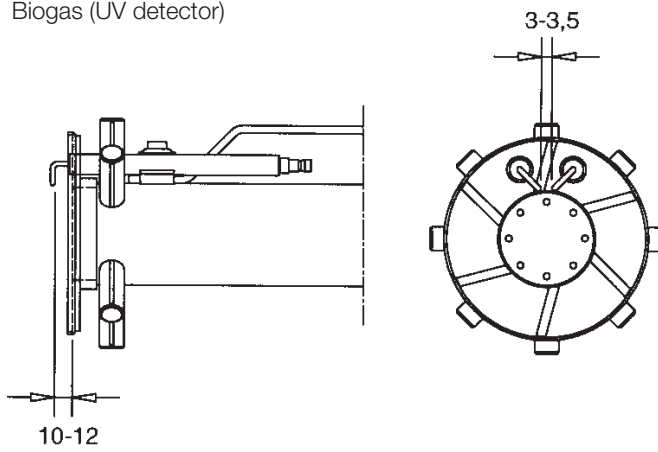

## 4.11 Setting Damper motor, modulating operation

### Air adjustment

The damper motor rotates the air damper between three preset positions: completely closed, low load and high load. These positions are controlled in the motor by colored cam discs:

- Orange cam disc is adjusted for low load (approx. 5-10°).
- Red cam disc is adjusted for high load (approx. 90°).
- Blue cam disc is factory set for closed air damper during standstill.
- Black cam disc has no function during sliding and modulating operation.

### Setting amount of gas

- Before starting the burner, vent the line so that gas is safely available at the multi-block.
- Connect a manometer for measuring outlet pressure (PBr).
- Set the control switch to the MAN position.
- Set gas pressure switch min and air pressure switch in position MIN and (if mounted) gas pressure switch max in position MAX.

- Start burner. If no flame is formed and the manometer does not give a reading, adjust the amount of gas by increasing with screw N on the multi-block. Check combustion values.
- Set high load by pressing "+" control switch (increase). Adjust the amount of gas with screw V on the multi-block and check the combustion values.
- Return to low load "-", check combustion value and adjust if necessary.
- If necessary, repeat the setting on low (N) and high load (V).
- Adjust the orange and red cam discs to obtain the desired effect on low and high loads. Check the amount of gas on the system's gas meter.
- Adjust air and gas pressure switches after adjustment, see special instructions.
- Set the control switch to the AUTO position.

### Release

By pressing the button, the motor is disengaged and the air damper can be turned. The function is used when servicing air dampers.

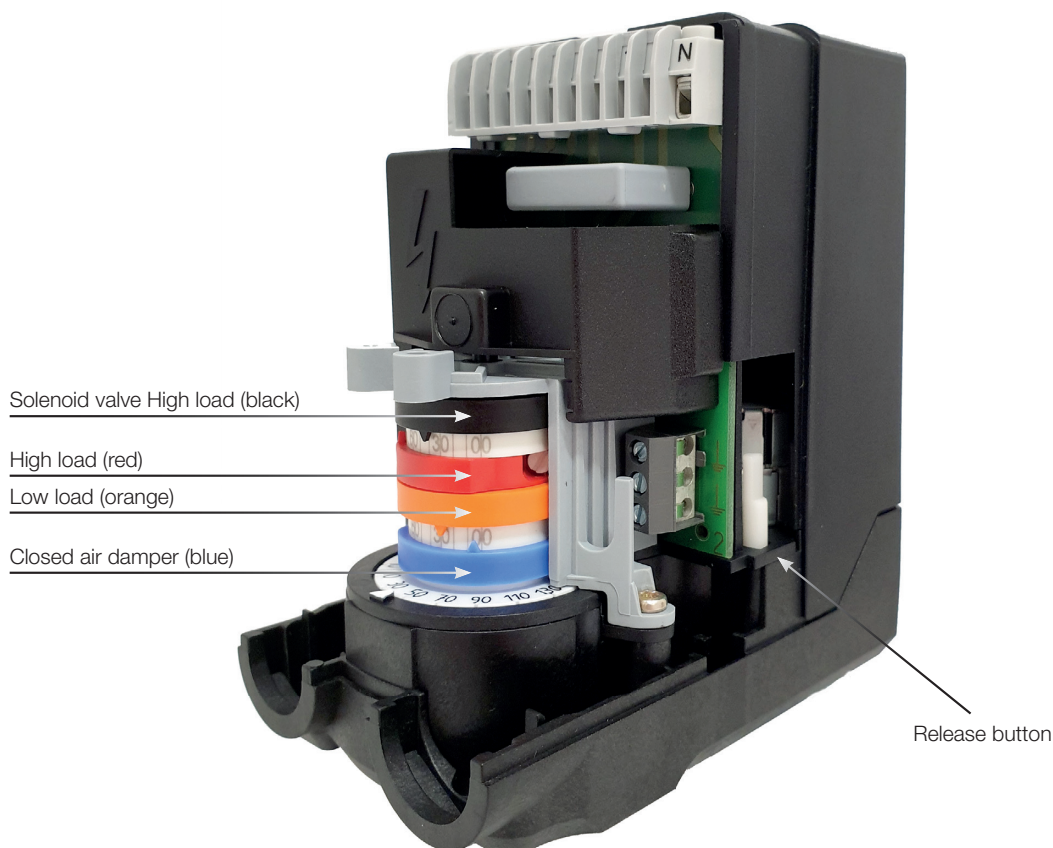

## 5. Setting the burner

### 5.1 Setting the combustion assembly

It may sometimes be necessary to adjust the combustion assembly, i.e. the position of the brake plate in the burner tube.

#### 5.1.1 Setting the combustion assembly,

The burner is equipped with a lever that changes the position of the brake plate in the combustion head. This is used to set the correct pressure drop across the combustion assembly and thereby obtain good combustion without ripples.

Make the adjustment by turning screw X.

The best position is, among other things, dependent on the input power and overpressure in the boiler.

A general rule of thumb is that the smaller the capacity, the smaller the gap should be between the brake plate and the combustion assembly.

The position of the brake plate also has an impact on the quantity of air supplied for combustion. This means that once the brake plate has been adjusted, the combustion should be checked and, if necessary, the setting of the air damper adjusted to obtain good combustion.

A left turn opens the brake plate, providing a lower pressure drop and more air to the combustion process.

A right turn closes the brake plate, providing a higher pressure drop and less air to the combustion process.

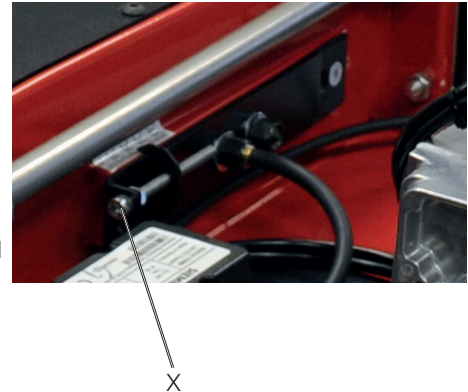

## 5.2 Setting the air pressure switch

The air pressure switch should block the burner if the air quantity supplied for combustion is insufficient. The air pressure switch must be set so that, if there is a defective air supply at the burner's max. or min. capacity, it reacts before the monitored pressure falls so much that it results in poor combustion.

Inställningsområde ca:

LGW 10	1-10	mbar
LGW 50	2,5-50	mbar

Setting for air pressure switch

1. Remove the protective cover, screw (Y).



Be careful when adjusting the air pressure switch; it contains a live component.

2. Start the burner.
3. Carefully turn the scale on the air pressure switch clockwise until the air pressure switch stops the burner. **Is the tolerance on the scale for the min. air pressure switch approx.  $\pm 15\%$ ?**
4. Try to find the pressure at which the burner stops for both the minimum and maximum input power by turning the scale. Make a note of the values and then set the air pressure switch on the basis of the highest pressure noted at which the burner stopped.
5. The air pressure switch should be set to a pressure approx. 10–15% lower than the highest noted pressure at which the burner stopped.
6. After setting the air pressure switch, perform repeated starts and run through the burner's set output range several times. This is to ensure the reliable function of the burner. If breakdowns or interruptions occur, the air pressure switch is probably set to a too narrow position.
7. Fit the protective cover, screw (Y).



## 5.3 Setting the min. gas pressure switch

The min. gas pressure switch should react to a burner connection pressure that is too low and in such cases prevent the burner from starting. If the connection pressure to the burner is too low during operation, the min. gas pressure switch should stop the burner. The burner can start again once the connection pressure has risen above the pressure set for the min. gas pressure switch.

Setting for min. gas pressure switch

1. Remove the protective cover, screw (Y).
2. Open the pressure outlet (X) and connect a manometer to measure the connection pressure.
3. Start the burner.
4. Measure and make a note of the connection pressure to the burner during normal operation at the highest input power.
5. Based on the desired connection pressure set, determine the connection pressure at which the gas pressure switch should stop the burner. Set the connection pressure at which the burner is stopped at a level where the burner is stopped before poor combustion occurs.
6. Set the min. gas pressure switch to this value by turning the scale.
7. Check the setting by carefully closing the ball valve while measuring the connection pressure.
8. When the min. gas pressure switch stops the burner, the value measured should then approximately correspond to the setting on the min. gas pressure switch. The tolerance on the scale for the min. gas pressure switch is approx.  $\pm 15\%$ .
9. Open the ball valve.
10. Remove the pressure gauge and close the pressure outlet (X).



Check the gas tightness.

11. Fit the protective cover, screw (Y).



## 5.4 Skeleton diagrams

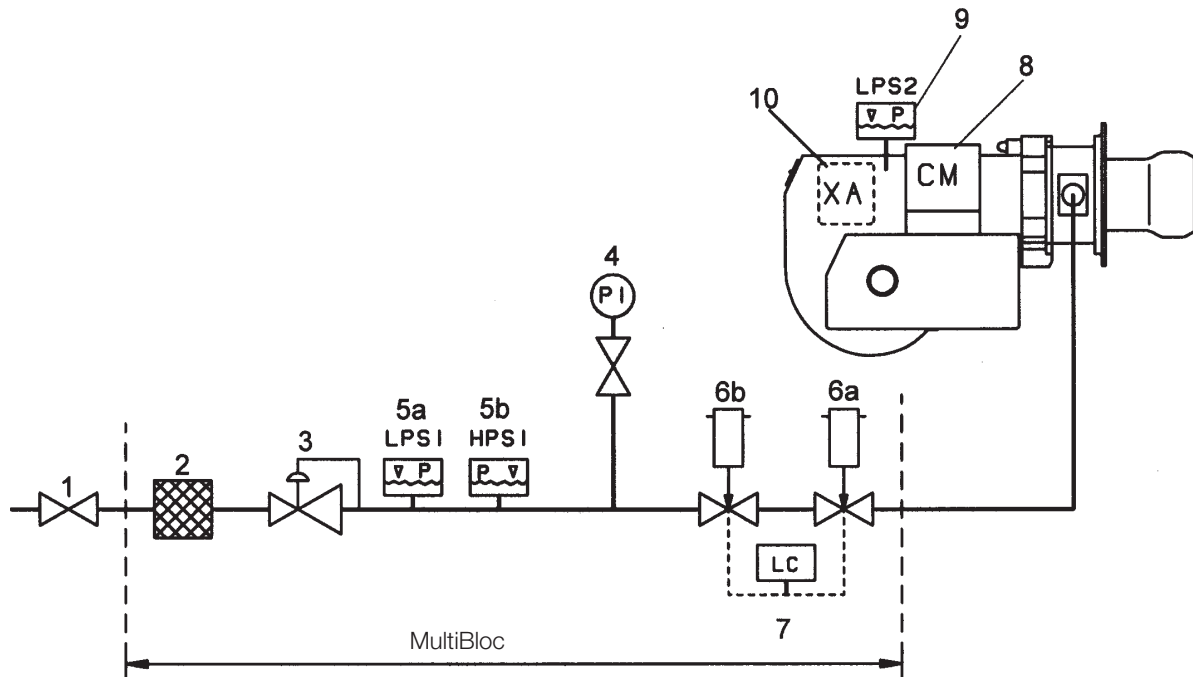

1. Ball valve
2. Filter
3. Governor
4. Pressure gauge with shut-off cock
- 5a. Gas pressure switch, mini
- 5b. Gas pressure switch, maxi
- 6a. Main valve, 2 -stage. When modulating operation is required this valve is equipped with controls for variable opening.
- 6b. Safety valve
7. <sup>1)</sup> Valve proving system
9. Air pressure switch
10. Gas burner control

Pos. 5b, 7: Components not required according to EN 676.

<sup>1)</sup> Required over 1200 kW according to EN 676.hhh

## 6. Multibloc MB-VEF 407-412

**!** All gasline components shall be assembled and mounted without bending, torque and other mechanical or thermal stress.

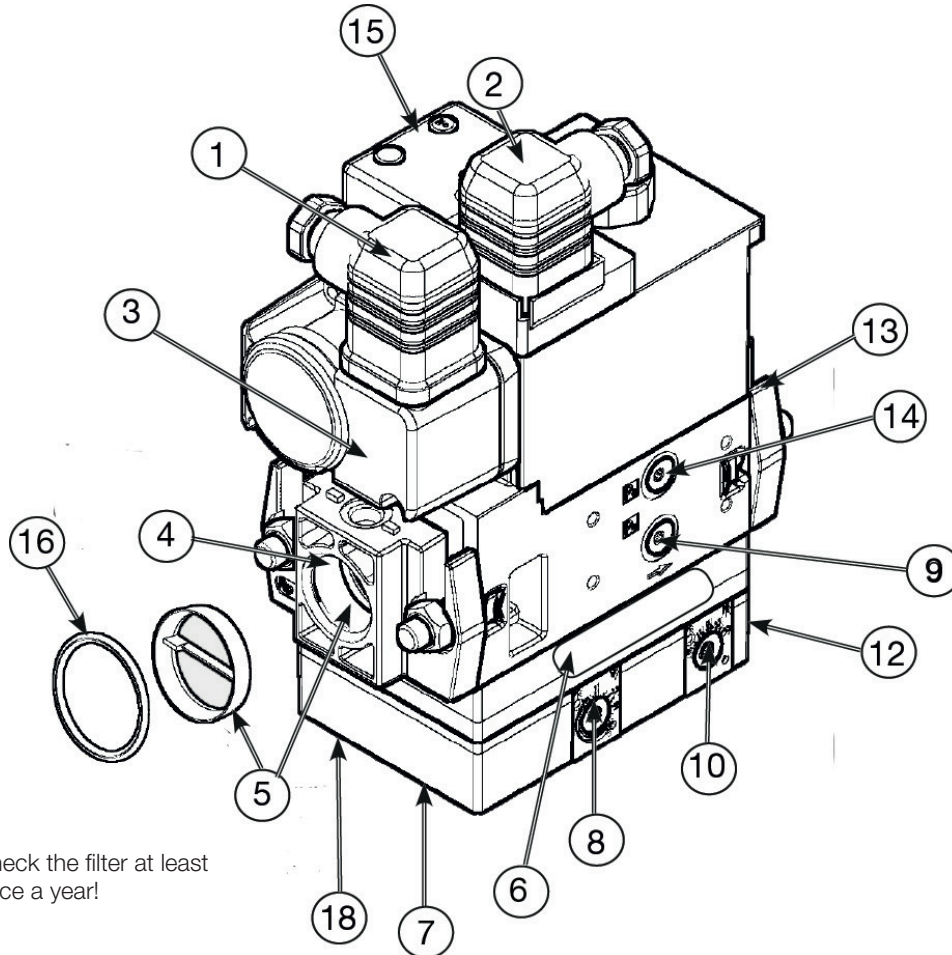

Check the filter at least once a year!

### 6.4.1 Components

- |   |  |  |
|---|--|--|
| 1. Electrical connection gas pressure switch mini | 7. Connection 1/8" $P_L$                                     | 12. Test point connection 1/8" $P_{Br}$                      |
| 2. Electrical connection gas valve                | 8. Adjustment screw V for ratio $P_{Br} : P_L$ (max. load)   | 13. Flange connection, outlet                                |
| 3. Pressure switch mini                           | 9. Test point connection 1/8" before V1 (before governor)    | 14. Test point connection 1/8" Pa before V2 (after governor) |
| 4. Flange connection inlet                        | 10. Adjustment screw for zero point adjustment N (min. load) | 15. Indication of V1 and V2 in operation (not standard)      |
| 5. Filter   | 11. Test point connection 1/8" $P_F$                         | 16. O-ring   |
| 6. Data plate                                     |  |  |

It is possible to connect a leakage control VPS 504 and a gas pressure switch maxi.

1) **NB.** The impulse line  $P_{Br}$  can be replaced by an impulse flange on the multibloc. The impulse line  $P_{Br}$  is then placed inside this flange.

### 6.4.2 Technical data

- Max inlet pressure 360 mbar
- Valves V1+V2 class A group 2 in accordance with EN 161
- Governor class A group 2 in accordance with EN88-1
- Ratio V PBr:PL 0,75:1-3:1
- Filter according to DIN 3386
- Ambient temperature -15°C- +70°C
- Protection standard type IP54 (according to IEC 529, DIN 40050)
- Gas family 1 +2 +3
- Outlet pressure 0,5 - 100 mbar
- Zero point adjustment  $N \pm 2$  mbar
- Pressure switch DIN3398 TI
- Fan pressure PLO,4-100 mbar
- Fire room pressure PF -2 --+5mbar
- Burner pressure PBr 0,5 - 100 mbar

### 6.4.3 Mounting instruction - impulse lines PL,PF och PBr

- Impulse lines should preferably be made of steel. Inside diametre  $> \phi 4$  mm (steel tube  $\phi 6/4$ ).
- For  $P_L$  other material can be used.
- Impulse lines  $P_L$  and  $P_{BR}$  are ready from factory.
- Impulse lines shall be mounted in such a way that no condensate can flow back into the multibloc. This is especially important when  $P_F$  is concerned.
- Impulse lines shall be mounted in such a way that they are protected against rupture and damage.
- Impulse lines shall be as short as possible.

### 6.4.4 Adjustment possibilities



Effective burner pressure

$$\Delta P_{Br} = P_{Br} - P_F$$



Effective fan pressure

$$\Delta P_L = P_L - P_F$$

Adjustment range

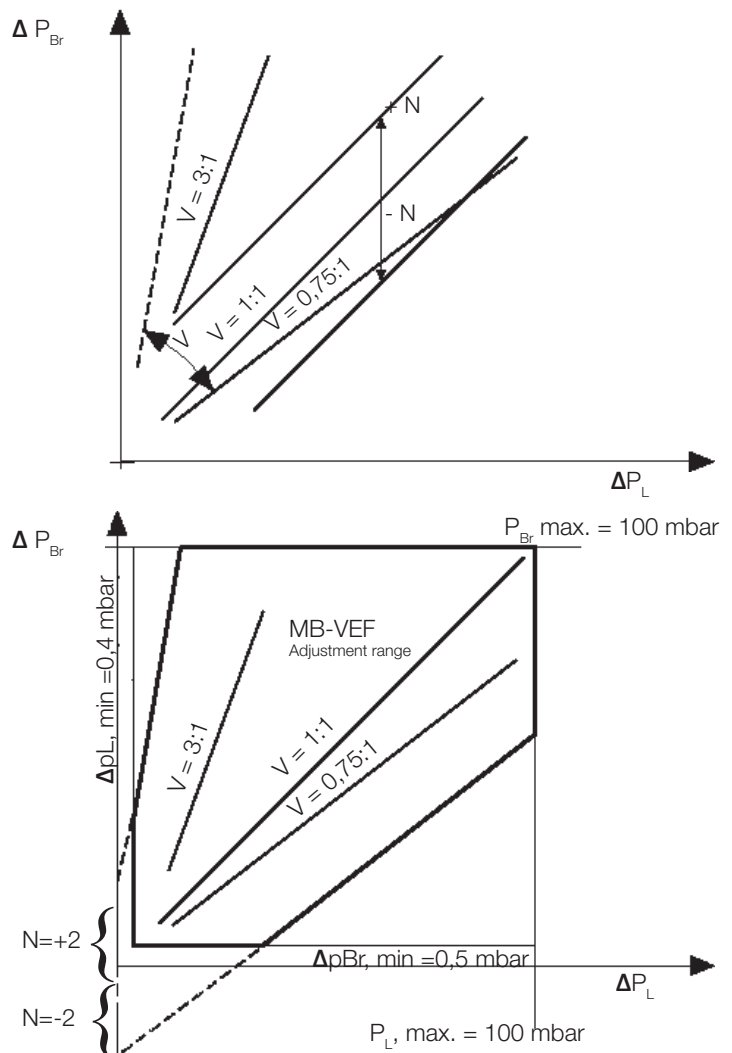



## 6.4.5 Pressure taps

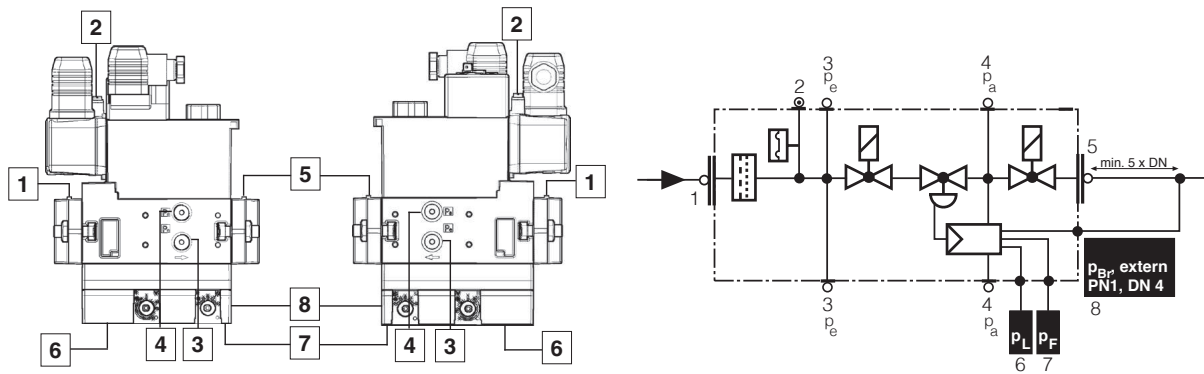

1,3,4,5 G 1/8 screwed sealing plug

2 Measuring nozzle

6,7,8 G 1/8 female thread for pL ,pF ,pBr pulse lines

## 6.4.6 Electrical connection

### S 10/S 30

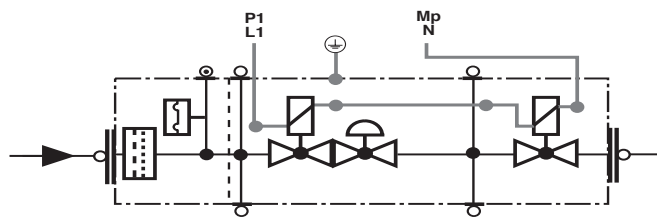
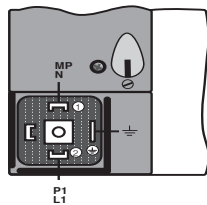

## 6.1 Recommended excess air when using default setting

Grade of gas	Excess air flue gases		Max. % CO <sub>2</sub>
	% O <sub>2</sub>	% CO <sub>2</sub> Lambda 1.2	
Natural gas	3-5	≈10	11.9
Propane	3-5	≈11.5	13.9
Butane	3-5	≈11,5	14,1
Biogas	3-5		

## 6.2 Determining the gas quantity for the system

The heat values indicated are normal values; the heat value varies according to the origin of the gas. For more exact information on values, contact the gas distributor.

Lower heat value Hu at normal state 15°C and 1013.25 mbar EN676

Grade of gas		kWh/Nm <sup>3</sup>	MJ/Nm <sup>3</sup>	kcal/Nm <sup>3</sup>
Natural gas	G20	9.5	34.02	8126
Natural gas	G25	8.2	29.25	6986
Butane	G30	32.5	116.09	27728
Propane	G31	24.6	88.00	21019
Biogas		6,0	21,60	5159

## 6.2.1 Example of how to calculate the gas quantity (natural gas G20)

$V_0 =$	Desired quantity of gas	[Nm <sup>3</sup> /h]
$Q =$	Boiler output	[kW]
$H_u =$	Gas heat value	[kWh/Nm <sup>3</sup> ] or [MJ/Nm <sup>3</sup> ] or [kcal/Nm <sup>3</sup> ]
$\eta =$	Boiler efficiency	[%]

Calculation example:

$$Q = 160 \text{ kW}$$

$$H_u = \text{Example A: } 34020 \text{ MJ/Nm}^3$$

$$\text{Example B: } 9.5 \text{ kWh/Nm}^3$$

$$\text{Example C: } 8126 \text{ kcal/Nm}^3$$

$$\eta = 90\%$$

$$V_{0A} = \frac{Q \cdot 3600}{H_u \cdot \eta} = \frac{160 \cdot 3600}{34020 \cdot 0.90} \approx 18.8 \text{ Nm}^3/\text{h}$$

$$V_{0B} = \frac{Q}{H_u \cdot \eta} \approx \frac{160}{9.5 \cdot 0.90} \approx 19 \text{ Nm}^3/\text{h}$$

$$V_{0C} = \frac{Q}{H_u \cdot 0.00116 \cdot \eta} = \frac{160}{8126 \cdot 0.00116 \cdot 0.90} \approx 19 \text{ Nm}^3/\text{h}$$

If the barometer reading (altitude), pressure and temperature of the gas deviate significantly from normal values, this must be taken into account as follows:

$T =$  Temperature of gas at the gas meter [°C]

$B =$  Barometer reading [mbar]

$P =$  Pressure of gas at the gas meter [mbar]

$f =$  Factor calculated for multiplication with flow in Nm<sup>3</sup>/h to arrive at actual flow in m<sup>3</sup>/h.

$V =$  Actual flow [m<sup>3</sup>/h]

$$f = \frac{273}{273+T} \cdot \frac{B+P}{1013.25}$$

Calculation example:

$$T = 15^{\circ}\text{C}$$

$$B = 945 \text{ mbar}$$

$$P = 15 \text{ mbar}$$

$$f = \frac{273}{273+15} \cdot \frac{945+15}{1013.25} \approx 0.90 \text{ Nm}^3/\text{h}$$

This means that the quantity of gas read from the gas meter should actually be read off as 1.11 . the calculated flow in a normal state.

$$\begin{aligned} V &= V_0 \cdot f \\ V_A &= V_{0A} \cdot f = 18.8 \cdot 0.90 \approx 17 \text{ m}^3/\text{h} \\ V_B &= V_{0B} \cdot f = 19 \cdot 0.90 \approx 17 \text{ m}^3/\text{h} \\ V_C &= V_{0C} \cdot f = 19 \cdot 0.90 \approx 17 \text{ m}^3/\text{h} \end{aligned}$$

## 6.3 Calculating the quantity of gas supplied

The quantity of gas supplied can be calculated if the system is equipped with a gas flow meter of some type. The procedure here is usually to measure how long it takes for the burner to consume a certain quantity of gas.

To measure:

t = Time for a certain quantity of gas consumed by the burner. [h]

M = Quantity of gas consumed. [m<sup>3</sup>]

V = Actual gas flow [m<sup>3</sup>/h]

$$V = \frac{M}{t} \text{ [m}^3/\text{h]}$$

Calculation example:

$$t = 1 \text{ min } 10 \text{ s}$$

$$M = 330 \text{ dm}^3 \text{ (litre)}$$

$$M = \frac{330}{1000} = 0.33 \text{ m}^3$$

$$t = \frac{1}{60} + \frac{10}{3600} = 0.0194 \text{ h}$$

$$V = \frac{M}{t} = \frac{0.33}{0.0194} \approx 17 \text{ m}^3/\text{h}$$

## 7. Service

Whoever carries out service and maintenance on the burner must be authorised to do so. If components need to be replaced, the replacements must be of the same make and type and be approved by the authorities. If the burner is to be used for a different grade of gas, a new adjustment must be carried out. If town gas is to be used, it is also necessary to convert the combustion assembly; in some cases the multi-block or valves and gas train may also need to be changed to a larger type.

### 7.1 Servicing the combustion assembly

Removal and installation

1. Switch off the main power supply and disconnect the Euro plugs from the burner.
2. Remove the cover and disconnect the ignition cable, ionisation cable and control arm (D) from the gas nozzle.
3. Loosen the nuts (B) and pull the burner body out of the guides.
4. Loosen the screw (A); this releases the combustion assembly and allows it to be lifted out.
5. Check and clean the brake plate and gas inlet. If necessary, replace the worn parts.
6. Check the ignition electrode (see chapter Gas nozzle). Replace if necessary.
7. Check the ionisation electrode (see chapter Gas nozzle). Replace if necessary.
8. Fit the combustion assembly in reverse order.
9. Press the burner together and lock using the nuts (B).
10. Fit the Euro plugs and turn on the main power supply.
11. Check/adjust the combustion.

**!** If the burner is directly connected, ensure that all components on the burner are without power.

**!** Check the gas tightness.

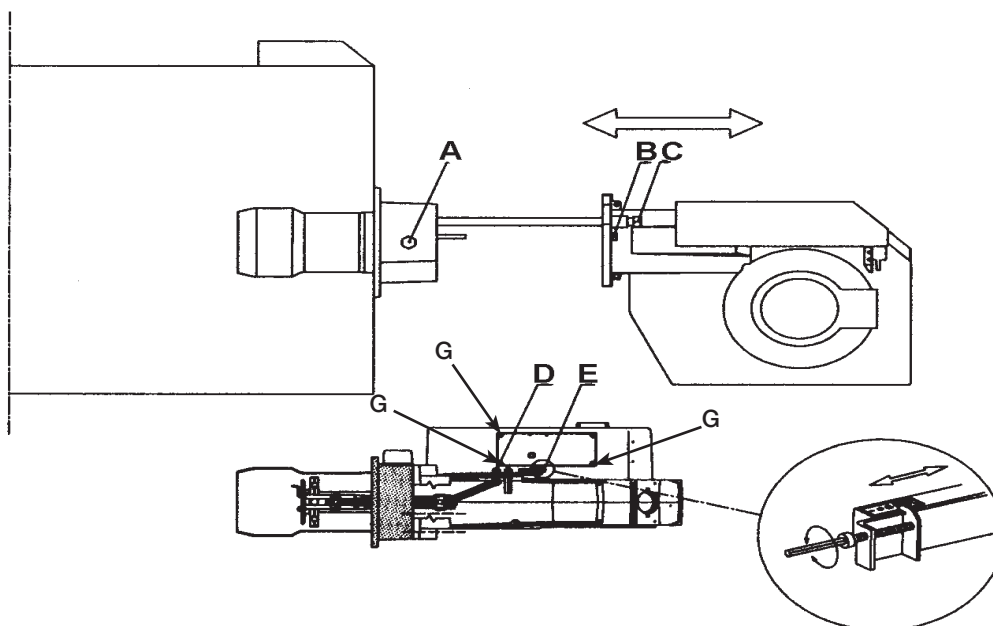

172 615 16 2018-01-15

## 7.2 Servicing air dampers

### Removal and installation

1. Switch off the main power supply and disconnect the Euro plugs from the burner.

**!** If the burner is directly connected, ensure that all components on the burner are without power.

2. Remove the cover and disconnect the ignition cable, ionisation cable and control arm (D) from the gas nozzle.
3. Loosen the nuts (B) and pull the burner body out of the guides.
4. Remove the intake grille at the air intake.
5. Remove the screws (G) securing the damper motor mounting plate.
6. Lift up the damper motor.
7. Clean the air damper and the intake. Lubricate any damper shaft.
8. Re-install the damper motor and mounting plate on the air intake. Ensure that the damper shaft and control arm are connected correctly.
9. Install the intake grille for the air intake.
10. Press the burner together and lock using the nuts (B).
11. Check/adjust the combustion.

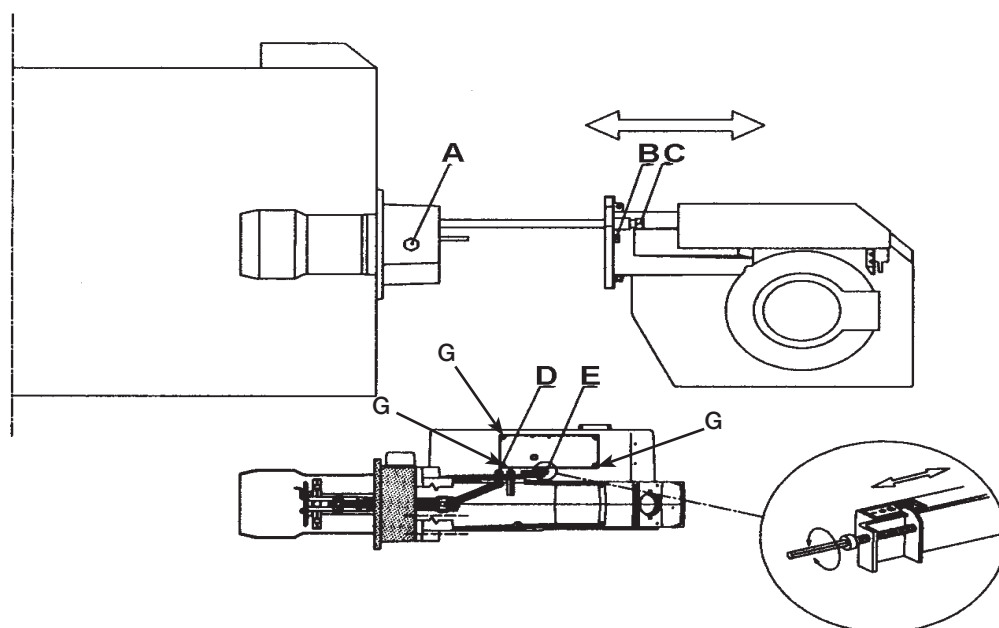

## 7.3 Replacement of damper motor, air

Removal and installation

1. Break the main current and disconnect the Euro plugs from the burner.

**!** If the burner is directly connected, ensure that all components on the burner are without power.

2. Note the connection position of the cables on the damper motor.
3. Disconnect the damper motor cable from the damper motor.
4. Loosen the screws (G) to the damper motor mounting plate.
5. Lift up the damper motor.
6. Remove the control arm from the motor shaft.
7. Remove the screws (I) securing the damper motor to the mounting plate.
8. Remove the damper motor from the mounting plate.
9. Install the new damper motor on the mounting plate.
10. Fit the control arm on the damper motor shaft. It is important that the screw is perpendicular to the plane of the shaft.
11. Re-install the damper motor and mounting plate on the air intake. Ensure that the damper shaft and control arm are connected correctly.
12. Connect the damper motor cable.
13. Fit the Euro plugs and turn on the mains power.
14. Check/adjust the combustion.



### - Releasing button

By pressing the button and snapping it down, the motor will be released and the damper can easily be turned. This function facilitates an exchange of damper motor.

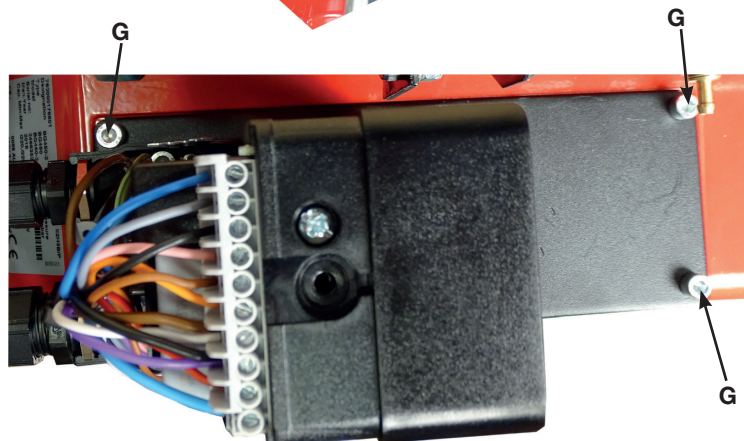
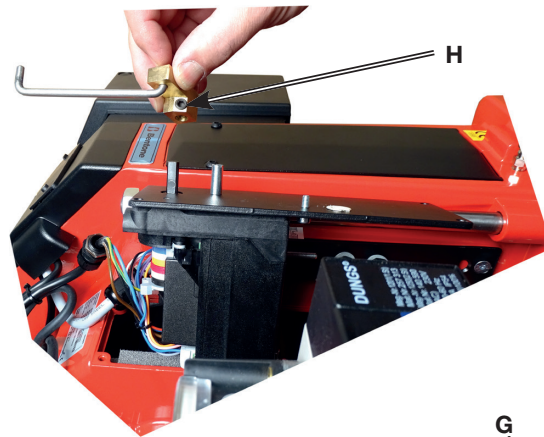
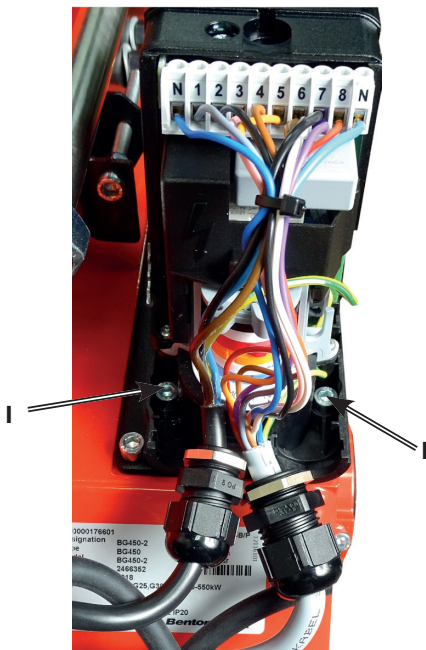

## 7.4 Vibration

Maximum vibration level are 5,0 mm/s

- Check all bolts and nuts for correct torque
- Check fan wheel for damage and contamination. Change when dirty/unbalanced
- Check motor bearings. If worn change motor/bearings

Use lid screw for  
sensor mounting





## 7.5 Flame monitoring and ionisation current check

The standard version of the burner is monitored according to the ionisation principle. The ionisation current should be checked on initial start-up and at each service visit.

Ionisation current is measured using a micro ammeter ( $\mu\text{A}$ ) connected in series with the ionisation electrode and gas burner control. Connect the  $\mu$  ammeter according to the diagram. The minimum required ionisation current is shown in the table. In practice, this current must be significantly higher, preferably more than  $10 \mu\text{A}$ . Connection of the  $\mu\text{A}$  instrument is made easier by the fact that all gas burners are equipped with a divisible ionisation cable.

The reason for low ionisation current can be leakage current, poor connection to earth, fouling or incorrectly positioned ionisation electrode in the combustion head. Occasionally, an incorrect gas/air mix may result in poor ionisation current.

### Technical data

For continuous operation!

Idle voltage at ION-terminals	AC 115-230V
 <b>Protect the ionisation electrode from electric shock!</b>	
Short-circuit current	Max. AC 100-300 mA
Min. current for flame detection	Min. DC $1.5 \mu\text{A}$
Required current to ensure detection	Min. DC $3 \mu\text{A}$
Possible detection current	Max. DC $20 \mu\text{A}$
Operational indicator lamp flashes green	$<5 \mu\text{A DC}$
Operational indicator lamp shines green	$>5 \mu\text{A DC}$

### 7.5.1 Flame monitoring ionisation

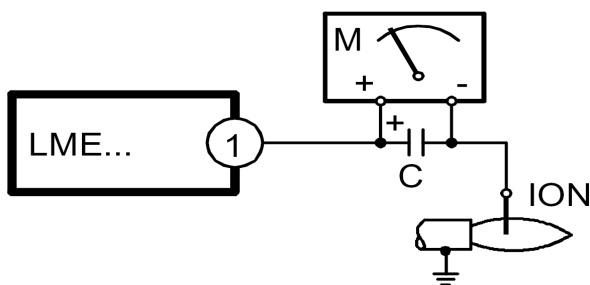

### 7.5.2 UV –detector (QRC)

Should not be exposed to temperatures higher than 60 °C. The current passing through the UV-detector, when it is lighted, should be at least 70 µA. The current can be measured with a moving coil instrument. A check is necessary only if a malfunction is suspected.

### 7.5.3 Flame monitoring UV-detector (QRC)

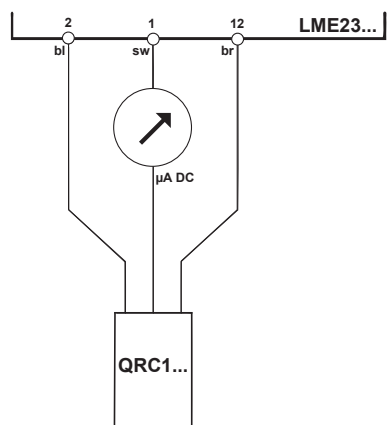

#### Technical data

For continuous operation!

Idle voltage at ION-terminals	AC 115-230V
 <b>Protect the ionisation electrode from electric shock!</b>	
Short-circuit current	Max. AC 100-300 mA
Max. current for flame detection	Max. DC 5.5 µA
Required current to ensure detection	Min. DC 40 µA
Possible detection current	Max. DC 60 µA
Operational indicator lamp flashes green	<45 µA DC
Operational indicator lamp shines green	>45 µA DC

## 8. Handing over of the installation

- Make repeated start attempts to ensure that the adjustments function.
- Close the ball valve during operation to check that the gas switch switches off at the set value.
- Remove the hose for the air pressure switch to check that the burner locks out.
- Check that all protective covers and measurement nipples are mounted and fastened.
- Fill out necessary test reports.
- Instruct the persons in charge of the operation on the service and maintenance of the installation and what to do should any troubles occur.
- Inspection and service must be carried out by authorized personnel.



Review and service should be performed by authorised personnel only.

## 9. Fault location, functional troubles

Trouble free operation is dependent on three factors: electricity, gas and air supply. Should there be any changes in the ratio between these three factors there is a risk of break downs. It has been proved that most break downs are caused by simple faults. Before calling the service engineer, the following should therefore be checked:

- Is the gas cock open?
- Are all fuses in order and the current switched on?
- Are the thermostats correctly set?
- Are pressostats, overheating protection etc. in operating position and not locked-out?
- Is the gas pressure sufficient?
- Is the gas burner control in start position?
- Has the gas control or the motor protector locked out? - Reset.
- Is the circulation pump in operation?
- Is there a supply of fresh air to the installation?
- If integral components are of a different make from what is stated in this manual, see the enclosed loose-leaf.

# 10. Electric equipment

## 10.1 Safety system

Safety systems must be installed in accordance with regulations that are applicable for the appliance. This may differ according to the process burner are installed in to. Se local regulations for information.

Safety system cables must be run in separate cables outgoing signal must not come in same cable as incoming signal. Signals must be in different harnesses for safety reasons.

Safety system as door switches, water level, pressure, temperature and other safety limiters must be installed in safety loop according to process.

## 10.2 Wiring diagram LME

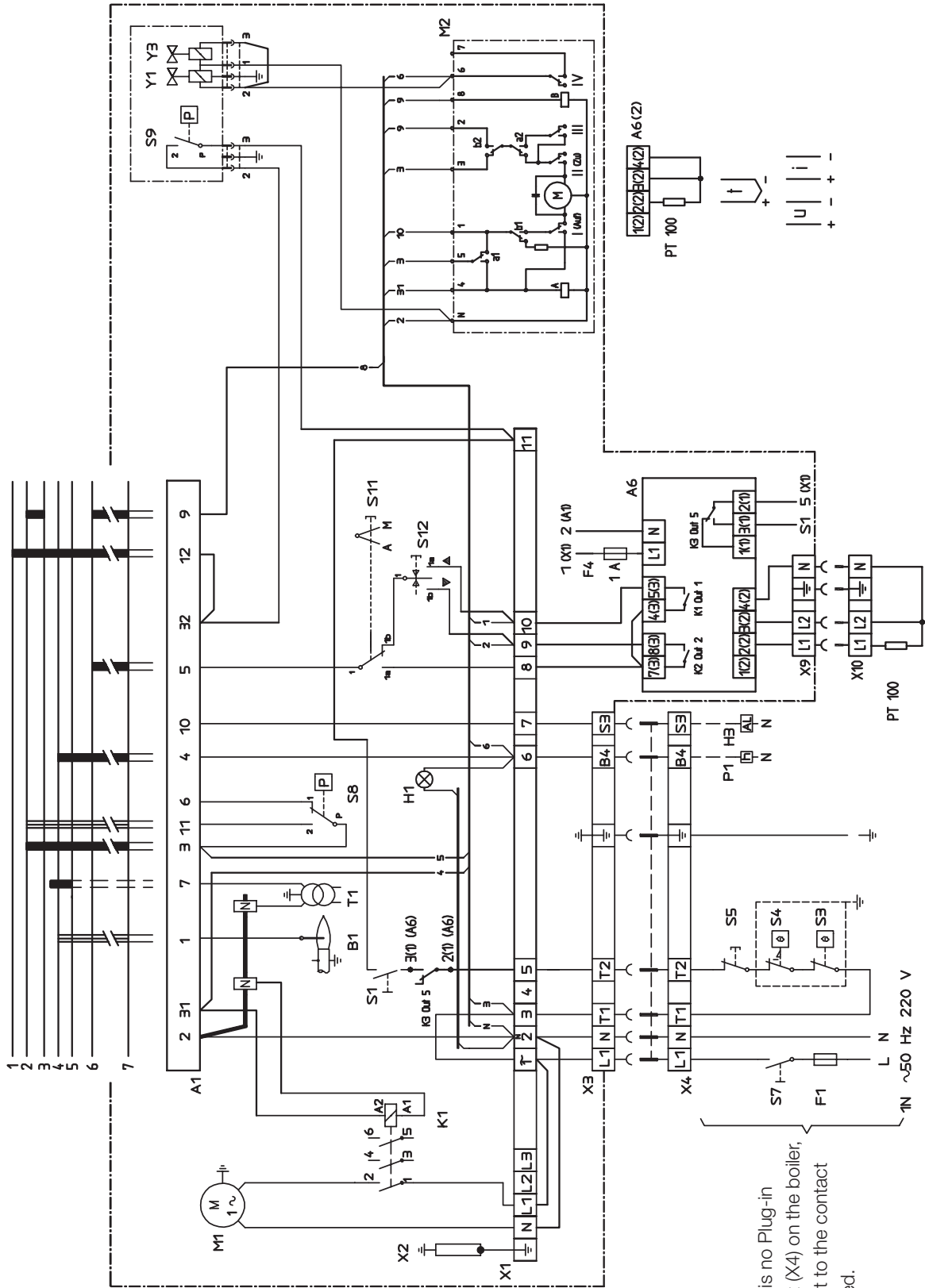

If there is no Plug-in contact (X4) on the boiler, connect to the contact enclosed.

## 10.2.1 List of components

A1	Gas burner control	P1	Time meter, total operating time	X1	Connection terminal board
A6	Power control R316			X2	Earth terminal
A6(2)	PT 100-sensor, Thermocouple, current/voltage	S1	Operating switch	X3	Plug-in contact, burner
B1	Ionization electrode	S3	Control thermostat	X4	Plug-in contact, boiler
F1	Operating fuse	S4	Temperature limiter	X9	Plug-in contact, power controller
F4	Operating fuse 1A	S5	Micro switch for hinged door		R316, burner
H1	Operating lamp	S7	Main switch	X10	Plug-in contact, power controller R316
H3	Alarm signal 230 V	S8	Air pressure switch		
K1	Contact	S9	Gas pressure switch	Y1	Gas solenoid valve 1
M1	Burner motor	S11	Change-over switch, Aut.-Man.	Y3	Safety solenoid valve
M2	Damper Motor, L&S SQN75.624A21B	S12	Change-over switch, Increase-Decrease		
		T1	Ignition transformer		

Max loading K1 Connection A1,A2 / 95, 96 / 97, 98 Max 0,2A/15W

## 10.3 Function LME...

<p><b>1. Operating switch ON-Thermostat ON-Gas pressure switch ON</b> A check that the air pressure switch <b>does not</b> indicate fan pressure is carried out</p>
<p><b>2. Burner motor starts</b> A check that the air pressure switch indicates sufficient fan pressure is carried out</p>
<p><b>3. The ignition spark is created</b></p>
<p><b>4. The gas solenoid valve is open</b> The gas is ignited. The ionisation electrode now indicates a flame</p>
<p><b>5. The safety time expires</b> The ignition spark ceases. The safety period ceases. If the spark is missing or it disappears after this time limit, the gas burner control is blocked</p>
<p><b>6. Operating position</b></p>
<p><b>7. Stop</b> The operation of the burner can now be stopped with the control switch or thermostat</p>
<p><b>If the gas burner control is blocked</b> Red light in the gas burner control is lit. The burner is restarted by pushing the reset button</p>

 Mains connection and fuse in accordance with local regulations.

### 10.3.1 Technical data

	LME22.233C2
Preignition time	3 s
Prepurge time	20 s
Postignition time	2.5 s
Safety lockout time	< 3 s
Reset time after lockout	< 1 s
Reaction time on flame failure	< 1 s
Min. ionisation current at flame	5 µA
Max. ionisation current	20 µA

160303-334

## 10.4 Control program at faults; fault mode indicator LME ....

### 10.4.1 Colour codes

Table colour codes for multi-coloured signal light (LED)		
Status	Colour codes	Colours
Waiting period «tw», other waiting periods	○.....	Off
Ignition phase, ignition controlled	●○ ●○ ●○ ●○ ●○ ●	Blinking yellow
Normal operation	□.....	Green
Operation, poor flame signal	□○□○□○□○□○□○	Blinking green
Illegal flame signal during start-up	□▲□▲□▲□▲□▲□▲	Green-Red
Undervoltage	●▲●▲●▲●▲●▲●▲	Yellow-Red
Fault, alarm	▲.....	Red
Blinking code for fault codes	▲○ ▲○ ▲○ ▲○	Blinking red
Interface diagnostics	▲▲▲▲▲▲▲▲▲▲	Red flicking

.....	Continuous
○	Off
▲	Red
●	Yellow
□	Green

#### 10.4.1.1 Diagnosing alarm causes

After alarm disconnection, the red alarm signal light is lit continuously. The diagnosing of the alarm cause can be read according to the following sequence:

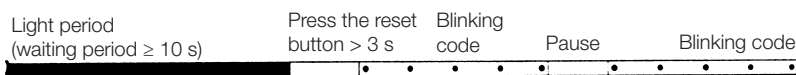

#### 10.4.1.2 Limiting of starting repetitions

LME 11... has a function with start repetition if the flame is not created at start or disappears during operation.. LME 11... allows max. three repetitions during continuous starting cycle.

### 10.4.1.3 Alarm code table

Red blinking code on signal lamp (LED)	Possible causes
Blinking 2 x ..	No flame creation at End of "TSA" - defective or fouled flame monitoring - defective or fouled fuel valves - poor burner setting - defective firing device
Blinking 3 x ...	"LP" defective - No air pressure switch signal after "t10" - "LP" is welded in open position
Blinking 4 x ....	Illegal flame signal during start-up
Blinking 5 x .....	Time out "LP" - "LP" is welded in open position
Blinking 6 x .....	Free
Blinking 7 x .....	Too many flame disappearances during operation - poor burner setting - defective or fouled fuel valves - defective or fouled flame monitoring
Blinking 8 x .....	Free
Blinking 9 x .....	Free
Blinking 10 x .....	Connection fault or internal fault, outgoing contacts or other faults
Blinking 14 x ..... ....	CPI contact not closed

During the diagnosing of the alarm cause, the control outputs are voltage-free.

- The burner is disconnected
- Exception, alarm signal «AL» at board 10
- Reconnection of the burner happens after resetting only.
- Press the reset button 0.5...3 s

### 10.4.1.4 Interface diagnostics

To change to interface mode, press and hold the reset button longer than 3 s. To go back to the normal position, press and hold the reset button longer than 3 s. If the gas burner control is in the alarm position, it is reset by pressing the reset button 0.5...3 s.



# 11. Troubleshooting

## Gas Burner

Conditions favourable to disruption-free operation of the system can only be guaranteed through the interaction between three factors – electricity, gas flow and combustion air. A change in any of these factors may cause disruptions.

It has been shown that a large proportion of disruptions can be attributed to relatively small things. Therefore, before requesting servicing, you should ascertain the following:

1. Are the system's gas taps open?
2. Are the fuses intact and is the power on?
3. Are control devices (room thermostat, boiler thermostat, etc.) correctly set?
4. Is gas pressure to the burner sufficient?
5. Are the burner controls on standby and not locked?
6. Is air supply to the burner adequate?

Cause of fault	Action
<b>Burner does not start:</b>	
No gas.	Make sure all gas taps are open.
No power.	Check the fuse, thermostat and electrical connections.
Burner motor does not start.	Motor protection has tripped. Motor faulty.
Burner control faulty.	Replace.
<b>Burner motor running, no ignition spark at the end of pre-aeration:</b>	
No power in the terminals.	Check the connector. Replace faulty burner controls.
Ignition electrodes in contact with each other or earth.	Adjust.
Ignition electrode porcelain damaged.	Replace the electrodes.
Poor connection to cable connectors.	Adjust connection.
Ignition cables damaged.	Replace.
Transformer damaged, no power to secondary winding.	Replace the transformer.
Ignition cable and ionisation cable swapped around.	Reconnect.
<b>No flame propagation:</b>	
Gas solenoid valve faulty.	Replace.
Gas solenoid valve does not open despite having power.	Replace solenoid valve terminals, or entire valve.
No power to solenoid valve.	Check the connection.
No electrical connection through air pressure gauge.	Check the air pressure gauge's settings and functions.
Ignition load incorrectly set.	Increase/decrease gas supply Reduce airflow.
Burner control faulty	Replace
Air pressure gauge incorrectly set or faulty	Check the settings and reset, or replace
No acknowledgement signal due to incorrect adjustment or misalignment of the control motor cams.	Check the settings and realign.

Cause of fault	Action
<b>Burner trips after safety time limit despite flame propagation:</b>	
No ionisation current or UV cell incorrectly positioned.	Adjust ionisation electrode and UV cell Check cables and connectors.
Burner control monitor faulty.	Replace burner control.
Voltage lower than 185 V.	Contact an electrician.
Ignition electrodes disrupting ionisation current.	Adjust ignition electrodes. Re-polarise the transformer.
Poor earth connection.	Ensure adequate earth connection.
Phase and neutral swapped around.	Check wiring diagram and change accordingly.
<b>Burner trips during pre-aeration:</b>	
Air sensor faulty or incorrectly set.	Increase/decrease air setting. Reduce air volume.
Ignition load incorrectly set.	Increase/decrease gas supply Reduce airflow.
Gas pressure too low.	Increase pressure. If necessary, contact gas supplier.
<b>Pulsations at start-up:</b>	
Ignition electrodes incorrectly set.	Adjust .
Gas pressure too high.	Check and adjust using pressure gauge and pressure control valve.
Flue gas side blocked.	Check the chimney flue.
<b>Burner pulsates during operation:</b>	
Burner incorrectly set.	Adjust.
Burner dirty.	Clean the burner.
Incorrect chimney.	Check and modify dimensions if necessary.
<b>Burner functioning properly but with occasional blockage:</b>	
Ionisation current too low.	Check. Must be at least 6 $\mu$ A, but should ideally lie between 8 and 20 $\mu$ A.
UV cell incorrectly positioned.	Adjust.
Voltage drop at certain times.	Must not drop below 15% of rated voltage. Contact an electrician if necessary.
Incorrectly set or faulty air sensor.	Check the settings and reset, or replace.
Ignition electrode overload.	Replace.
Burner control ambient temperature too high.	Insulate for heat, Max. 60 °C.
Ignition spark too weak.	Check the transformer.
<b>Poor combustion:</b>	
Poor draught conditions.	Check the chimney.
Flue gas temperature too high.	Boiler overloaded Decrease the gas volume, sweep the chimney if necessary.
CO <sub>2</sub> content too low.	Choke the air supply. Check the boiler for any leakages. Choke the draught if too high.

Cause of fault	Action
<b>CO content too high:</b>	
Surplus air when using natural gas and liquefied petroleum (propane, butane).	Choke the air supply.
Poor air supply.	Open the air supply. Check flue gas damper.
Holes in gas nozzle clogged.	Clean.
Poor fresh air intake.	Check and increase.
Flame at incorrect angle due to combustion head out of position.	Check the combustion head and readjust.
<b>Condensation build up in boiler and chimney:</b>	
Flue gas temperature too low or gas volume too low.	Raise the flue gas temperature by increasing gas volume Insulate the chimney.

# 12. General instructions for gasburners

## 12.4.1 Installation

1. Follow standards and instructions applicable to the installation of gas burners.
2. Ensure that the electric installation is made in accordance with existing regulations.
3. Check that the fresh air intake of the boiler room is sufficiently dimensioned.
4. Check by studying the data plate that the efficiency of the burner is adapted to the boiler output.
5. Check that the burner is adapted to the gas quality in question.
6. Check that the input pressure of the gas is correct.
7. Check that the dampers of the boiler are open.
8. Check that there is water in the system.
9. Check that thermostats etc. are correctly adjusted.
10. Read the instructions and follow the directions given for the burner as to starting-up and service.

## 12.4.2 Maintenance

### General instructions

1. Keep the boiler room clean.
2. Ensure that the fresh air intake of the boiler room is not restricted.
3. Switch off the current and shut off the gas supply if the burner must be withdrawn from the boiler.
4. Do not use the boiler for burning paper and waste if there is no special arrangement ( fire room ) for this.

### Normal operation

1. Ensure that the air supply to the burner is not obstructed by dust and dirt.
2. Have the installer make a yearly overhaul of the installation so that safety is not jeopardized.
3. Have the installer at the yearly overhaul also adjust the burner to ensure optimal combustion economy.
4. Check periodically that there is water in the system ( fill up if necessary ) and that thermostats etc. are normally adjusted.
5. Ensure that there is no water or dampness in contact with the burner.

## 12.4.3 If the burner has stopped

1. Press the reset button of the relay.
2. Check that the max. thermostat has not cut out.
3. Check other thermostats for example room thermostat, if any.
4. Check that the gas pressure to the burner is sufficient.
5. Check that the electric fuses have not blown.
6. Make a new attempt to start the burner and check the counter of the gas meter to find out whether the solenoid valve opens.
7. If the burner does not start in spite of repeated starting attempts call the installer.

## 12.4.4 Shut-Off

1. Switch off the current with the main switch.
2. Shut-off the gas supply with the shut-off cock on the burner.

## 12.4.5 Warning

1. Never keep your face in front of the fire room door when starting up the burner.
2. Do not use naked flame when inspecting the fire room.

Authorized installer::

-----

Address: .....

Telephone: .....



# EU Declaration of conformity



## Bentone Gas Burners

Certificate No.	Type	Certificate No.	Type
CE-0123CT1269	BFG 1	CE-0123CT1326	BG 550
CE-0123CT1270	STG 120	CE-0123CT1337	BG 600
CE-0123CT1281	STG 146	CE-0123CT1348	BG 650
CE-0123CT1292	BG 300	CE-0123CT1359	BG 700
CE-0123CT1304	BG 400	CE-0123CT1360	BG 800
CE-0123CT1315	BG 450	CE-0123CT1371	BG 950

This declaration of conformity is issued under the sole responsibility of the manufacturer. The object of the declaration described above is in conformity with:

**Gas Appliance Regulation 2016/426/EU**

**Machinery Directive 2006/42/EC**

**EMC 2014/30/EU**

**Restriction of the use of certain hazardous substances (RoHS) Directive 2011/65/EU**

References to the relevant harmonised standards used or references to the other technical specifications in relation to which conformity is declared:

EN 676+A2:2008

Excluded Annex J/K. Automatic forced draught burners for gaseous fuels

Additional information can be downloaded at:

[www.bentone.com](http://www.bentone.com)

**Enertech AB**

**Box 309**

**S-341 26 LJUNGBY**

Ljungby, January 26<sup>th</sup> 2021

Helene Richmond

Managing Director

Enertech AB



