



Installation and Maintenance Manual

Pro 450i M

LMV37

VGD20.40 SKP15/25

IP54

Translation of the original instructions.

Keep for future use.

Read carefully before use.

178 023 75-5 CR00782 2024-03-18

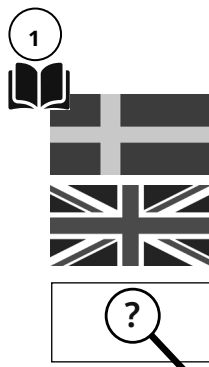

MADE IN SWEDEN

**-sv****1. Manualer på övriga språk**

2. [www.bentone.com\nedladdning](http://www.bentone.com/nedladdning) eller scanna QR-koden.

3. Skriv in brännarens artikelnummer som finns på din typskylt (se bild) och välj ditt språk.

Detaljerad ecodesign information kan laddas ner på:
www.bentone.com/ecodesign.

-fr**1. Manuels dans d'autres langues**

2. www.bentone.com/download ou scannez le code QR.

3. Saisir le numéro d'article du brûleur sur votre plaque signalétique (consultez l'illustration) et sélectionnez la langue.

Des informations détaillées sur l'ecodesign peuvent être téléchargées à l'adresse:
www.bentone.com/ecodesign.

2

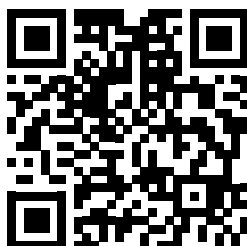
**-en****1. Manuals in other languages**

2. www.bentone.com/download or scan QR-code.

3. Enter the burner's article number on your data plate (see picture) and select language.

Detailed ecodesign information can be downloaded at:
www.bentone.com/ecodesign.

-de**1. Gebrauchsanweisungen in anderen Sprachen**



2. www.bentone.com/download oder scannen Sie den QR-Code.

3. Geben Sie die Artikelnummer des Brenners auf Ihrem Typenschild ein, (siehe Bild) und wählen Sie die Sprache aus.

Detaillierte Informationen zum Ecodesign können unter
www.bentone.com/ecodesign heruntergeladen werden.

3

exempel example Beispiel

352011030141	Serial no. 1234567	Man.Year 2019
Designation	BF 1 KS 76-24	
Type	BF 1	
Model	BF 1 KS 76-24	
Cap. Min-Max	LIGHT OIL 35-90kW 1,25-6,0 cSt 7-14bar	
Main supply	1-230V 1,0A 50Hz IP 20	
Motor supply		
MADE IN SWEDEN BY		

-da**1. Manualer på andre sprog**

2. www.bentone.com/download eller scan QR-koden.

3. Indtast brænderens artikelnummer, der findes på typeskiltet (se billede), og vælg dit sprog.

Detaljerede oplysninger om ecodesign kan downloades på:
www.bentone.com/ecodesign.

Table of contents

1. General Information.....	5	9. Mounting	82
1.1 Delivery inspection.....	5	9.1 Gas nozzle.....	83
1.2 Safety	5	9.2 De-aerating.....	84
1.3 What to do if you smell gas.....	6	9.3 Leakage control.....	84
2. Technical data.....	7	9.4 Calculate prepurge time, Industrial applications	85
2.1 Dimensions Pro 450i M.....	7	9.5 Calculation of gas flow	86
2.3 Gas categories, approved gases.....	8	10. Settings	87
2.2 Capacity range.....	8	10.1 Brake plate adjustment	87
2.4 Technical specification	9	10.2 Setting the air damper.....	87
2.5 Working field.....	9	10.3 Setting the gas damper.....	87
2.6 Components.....	10	10.4 Startup.....	88
2.7 Skeleton diagram.....	12	10.5 Control of combustion	88
3. Electric equipment.....	13	10.6 Setting the air pressure switch	89
3.1 Safety system	13	10.7 Setting the gas pressure switch, min.....	90
3.2 Components.....	13	10.8 Setting the gas pressure switch max/ overload protection switch	91
3.3 Wiring diagram	14	10.9 Setting the gas pressure switch VPS.....	92
4. Automatic control unit LMV37	15	11. Gas valve VGD20... SKP15/25	93
4.1 System structure/Function description.....	15	11.1 Technical specification	93
4.2 General information	16	11.2 Overview	94
4.3 Technical data Basic unit LMV37.4.....	16	11.3 Installation position.....	95
4.4 Connection and internal diagram.....	20	11.4 Adjusting the gas valve.....	95
5. Operation	22	11.5 Actuator SKP15.....	95
5.1 LMV37 automatic control unit.....	22	11.6 Actuator SKP25.....	95
5.2 List of phase displays	24	11.7 Gas damper VKG.....	97
5.3 Automatic control unit levels.....	25	11.8 SQM Damper motor	98
5.4 Manual output	29	12. Service.....	99
5.5 Setting the automatic control unit	30	12.1 Burner Service Schedule, Gas	99
5.6 Backup and restore	47	12.2 Component replacement intervals.....	99
5.7 Fault status message, display of errors and info	51	12.3 Combustion device	100
5.8 Display message of info.....	55	12.4 Air damper.....	101
5.9 Resetting the automatic control unit.....	56	12.5 Replacement of damper motor, air	102
6. Parameter list.....	57	12.6 Replacement of damper motor, gas.....	103
7. Error code list	66	12.7 Fan	104
8. Installation.....	80	12.8 Vibrations.....	105
8.1 General instructions.....	80	12.9 Kontroll av flamövervakning och joniseringsström	106
8.2 Instructions	80	12.10 Replacement of electrical components.....	107
8.3 Inspection and maintenance.....	80	13. Handing over of the installation	108
8.4 Preparation for assembly	80	14. Troubleshooting.....	109
8.5 Gas supply	80	15. Service- and inspection protocol	111
8.6 Electric connection	80		
8.7 Handling and lifting instruction	81		

1. General Information

The burner may only be used for its intended purpose in accordance with the product's technical data.

We reserve the right to make design changes and cannot be held liable for any misprints or typographical errors.

Modifying the design or using accessories or components that have not been approved by CTC in writing is strictly prohibited.

This Installation and Maintenance manual:

- is to be regarded as part of the burner and must always be kept near the installation site.
- must be read prior to installation.
- is intended for use by authorised personnel.

1.1 Delivery inspection

- Make sure everything is delivered and the goods have not been damaged during transit. Transport damage should be reported to the shipping company.
- If something is wrong with a delivery, report it to the supplier.

1.2 Safety

- before installation:

- Installation and work on the burner and associated system components may only be carried out by persons who have undergone relevant training.
- The product is packaged to prevent damage from occurring when handled – Handle the product with care! Lifting equipment must be used to lift larger packages.
- The products must be transported/stored on a level surface in a dry environment, max. 80% relative humidity, no condensation. Temperature -20 to +60 °C.



- installation:

- The burner must be installed in accordance with local regulations for fire safety, electrical safety, and fuel distribution.
- The premises must comply with local regulations pertaining to use of the burner and must have adequate air supply.
- The installation site must be free of chemicals.
- Fire extinguisher with Class BE recommended.
- Make sure when installing the burner that there is enough space to service the burner.
- The electrical installation must be professionally carried out in accordance with current mains electricity regulations and in a professional manner.
- Make sure that the burner is suitable for the application (see Technical Data).
- All components must be installed without being bent, twisted or subjected to mechanical or thermal forces that affect components.

- Care must be taken by the installer to ensure that no electrical cables or fuel lines are pinched or otherwise damaged during installation or service.
- Sharp edges can occur on, for example: flame tube, fan wheel and air damper.
- The gas outlet from the pressure regulator must be configured in accordance with applicable regulations and lead to a safe area.

- before first start:

- The burner must not be put into operation without proper safety and protection devices.
- Permitted ambient temperature during operation -10 to +60 °C. Max. 80% relative humidity, no condensation.
- The surface temperature of the burner's components may exceed 60 °C.
- Handle with caution – the burner has moving parts, and there is risk of crushing injuries.
- Seal inspections must be performed during installation and servicing to prevent leakage.
- Fitting and installation work has been completed and approved.
- Electrical installation has been correctly performed.
- Flue gas ducts and combustion air ducts are not blocked.
- All actuators and control and safety devices are in working order and correctly set.
- If the boiler is equipped with an access hatch, this must be equipped with a hatch opening switch connected to the burner's safety system.
- When in operation, the burner's noise level can exceed 85 dBA – use hearing protection!

- operation:

- Carry out all stipulated settings, service and inspection work within the set time.

1.3 What to do if you smell gas

- Turn off the fuel supply.
- Turn off the device and remove the boiler from operation.
- Open windows and doors.
- Prevent open flames or sparking, e.g. do not turn lights on or off, do not use any electrical appliances or mobile phones.
- Evacuate the building.
- Notify the installer or gas supplier of the problem so that it can be rectified.



2. Technical data

The burner is intended for:

- Operation in installations according to EN 303, EN 676 and EN 746-2.

Fuels:

- Natural gas H, E, L, LL.
- LPG, Butane and Propane.

2.1 Dimensions Pro 450i M

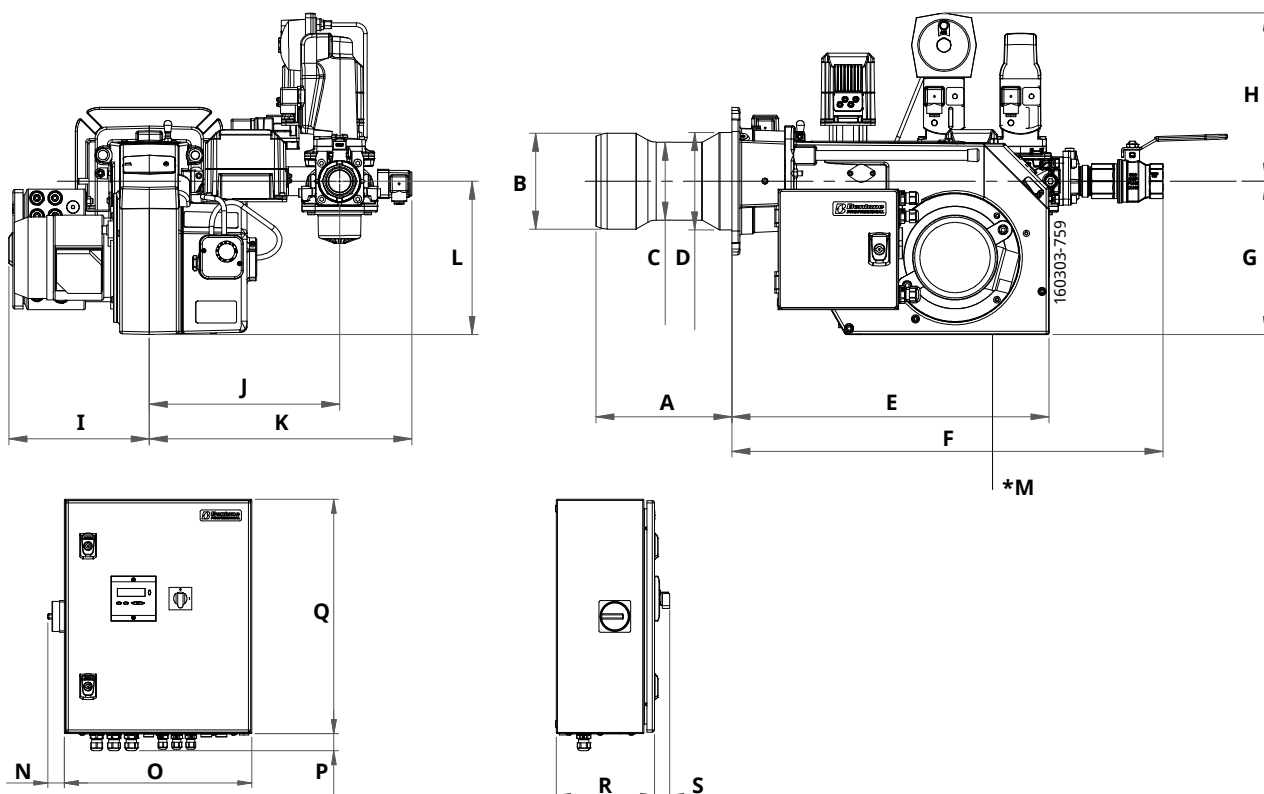

Length of flame tube	Flame tube measure A	Flame tube measure B	Flame tube measure C	Flame tube measure D
256	226	ø159	ø129	ø162
356	326	ø159	ø129	ø162
456	426	ø159	ø129	ø162

E	F	G	H	I	J	K	L	*M
526	715	255	279	233	316	436	255	200

* Min. recommended distance to floor.

N	O	P	Q	R	S
35	400	37	500	210	32

2.1.1 Measurements for connection to the boiler

K	L	M
14	(Ø 210) Ø 255-290	Ø170

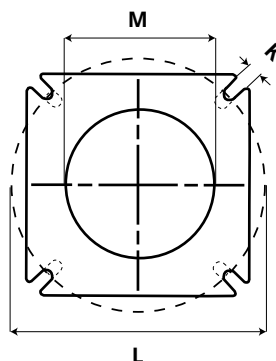

2.2 Capacity range

Capacity kW	Gas quantity at min. power Nm ³ /h	Gas quantity at max. power Nm ³ /h	Max. connection pressure mbar	Min connection pressure mbar
450 / 450i				See data plate.
G20 120 - 550	12.7	58.2	360	
G25 120 - 550	14.8	67.7	360	
G30 120 - 550	3.7	17.1	360	
G31 120 - 550	4.9	22.5	360	
Biogas 120 - 500	20.0	83.3	360	40

160303-681-2

Gas quantity and capacity vary according to grade of gas and connection pressure.

2.3 Gas categories, approved gases

Only dry gas is permitted for use.

Category	Country of destination	Supply pressure
II _{2R3R}	AT, BE, BG, CH, CY, CZ, DE, DK, EE, ES, FI, FR, GB, GR, HR, HU, IE, IS, IT, LT, LU, LV, MK, MT, NL, NO, PL, PT, RO, RS, SE, SI, SK, TR	20 mbar
II _{2H3B/P}	AT, CH, CY, DK, FI, LT, RO, SE, SK	20 mbar
II _{2H3P}	GB, IE	20 mbar
II _{2L3B/P}	RO	20 mbar
II _{2E3B/P}	PL	20 mbar
I _{2E(R)B}	BE	20 mbar
I _{3P}	BE	20 mbar
II _{2EK3B/P}	NL	20 mbar

160302-239-4

2.4 Technical specification

Pro 450i M	
Main supply, Operation ²⁾	230V, 1~, 0.6A, 50Hz, IP54
Main supply, Motor ¹⁾	230/400V, 3/1.7A
Max fuse rating, Operation	-
Max fuse rating, Motor	10A
NO _x -class	3
Sound power (dBA) LWA	89dBA

¹⁾ Max operating current, see data plate.

²⁾ Motor excluded.

Measurements according to EN 15036-1:2006

Alt.1 The noise level of the burner can be reduced by equipping the burner with silencer. Installation must be done so it does not prevent air supply to the burner.

Alt.2 The burner's noise level can be reduced by connecting the burner's air intake to the air duct that opens into an appropriate location. Installation must be done so it does not prevent air supply to the burner.

2.5 Working field

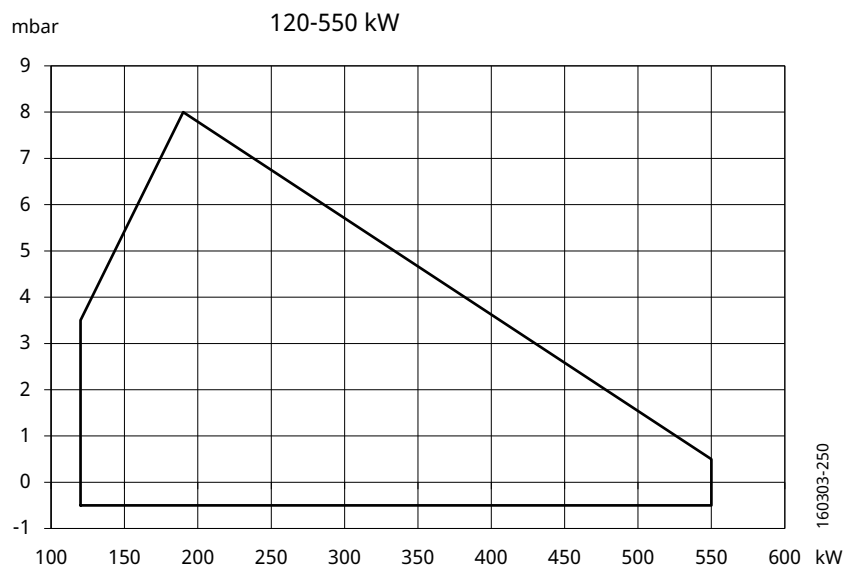

! Do not exceed working field.

2.6 Components

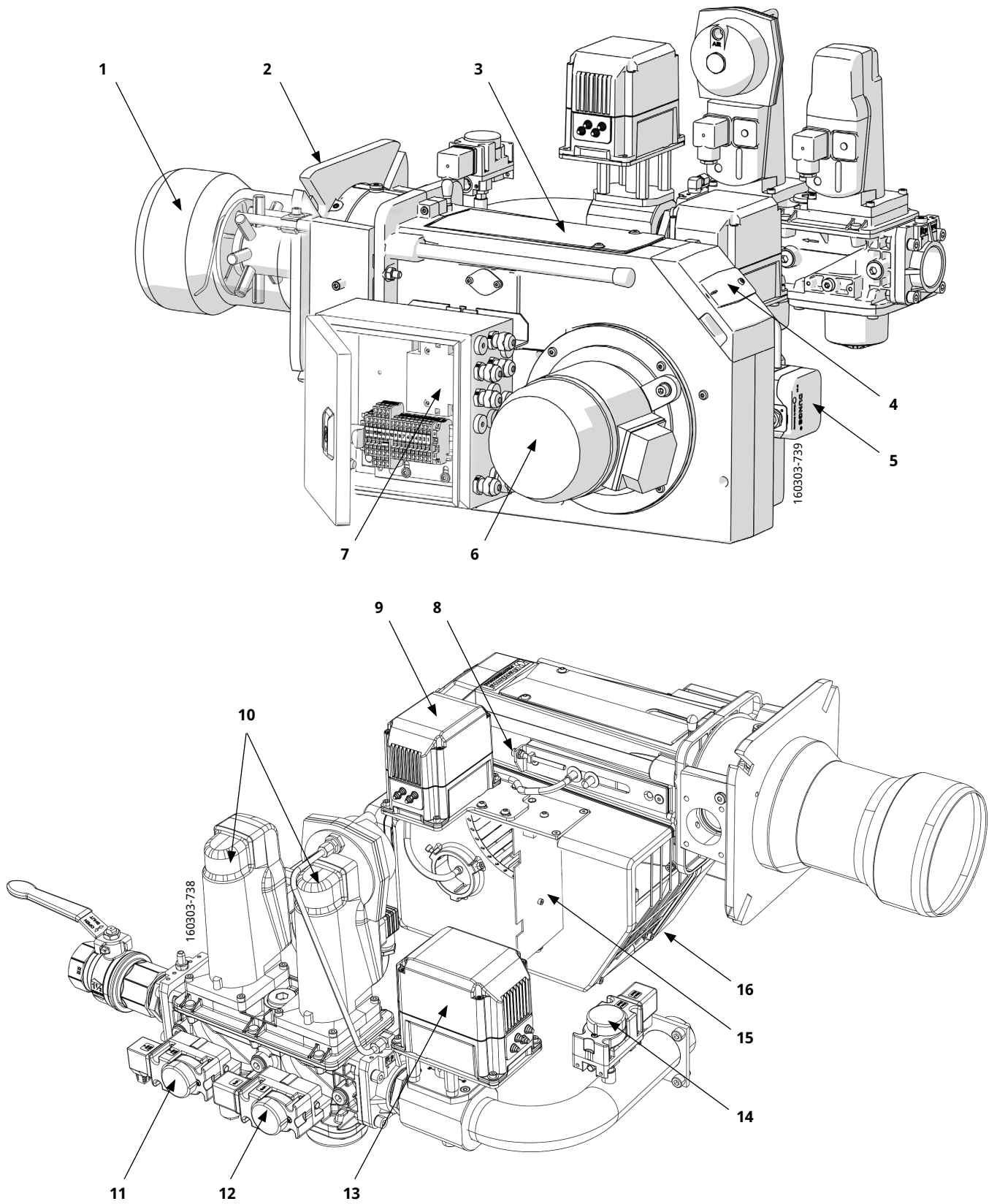

1. Flame tube
2. Fixing flange
3. Cover, fan housing
4. Cover, inspection glass
5. Air pressure switch
6. Motor
7. Transformer
8. Brake plate adjustment
9. Damper motor, air
10. Gas valve
11. Gas pressure switch, min
12. Gas pressure switch, VPS
13. Damper motor, gas
14. Gas pressure switch, max
15. Air damper
16. Air intake
17. Ignition electrode
18. Brake plate
19. Ionization electrode
20. Nozzle

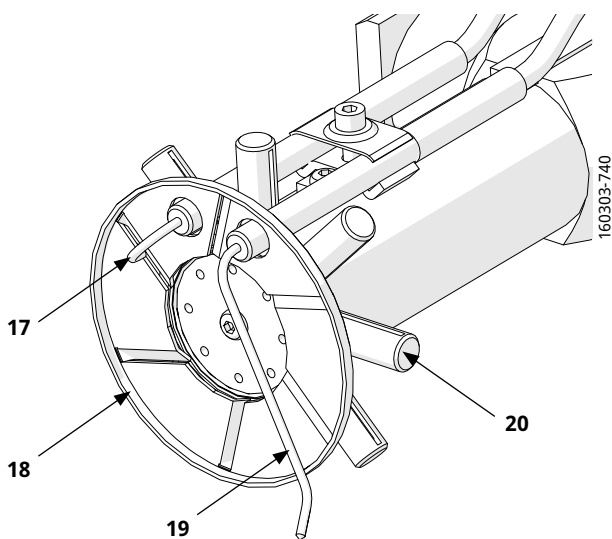

2.6.1 Components - Electrical cabinet (Automatic control unit)

21. Main switch
22. Automatic control unit LMV
23. AZL display for LMV Automatic control unit
24. Reset button
25. Switch 0-I
26. Contactor
27. Overload protection
28. Fuse

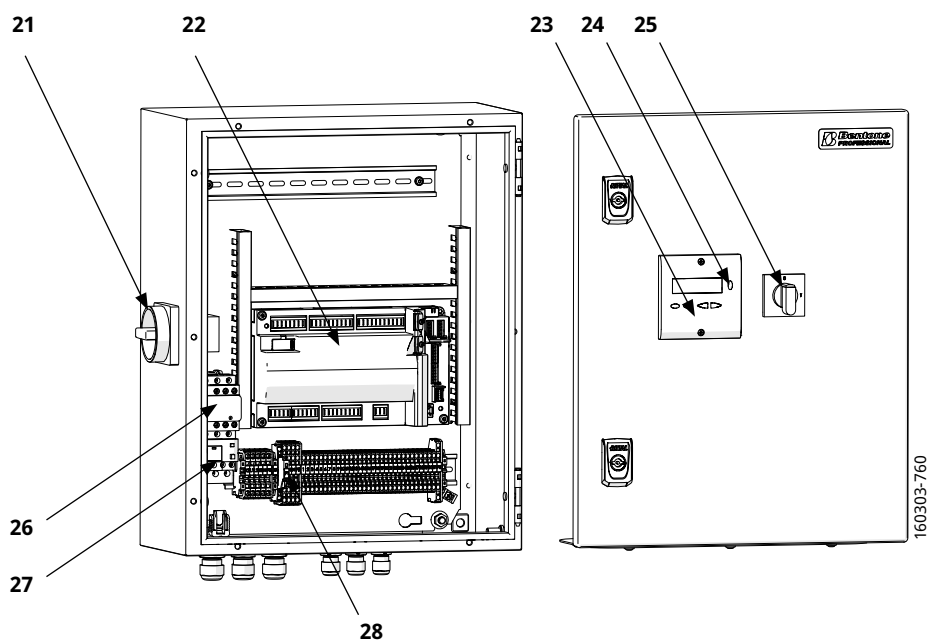

2.7 Skeleton diagram

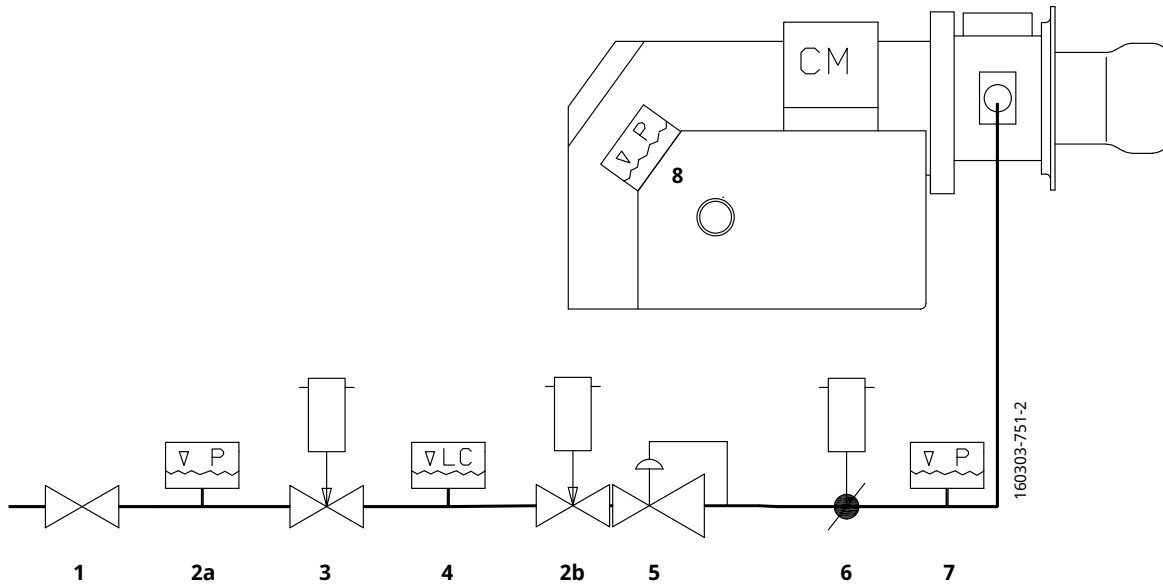

1. Ball valve
- 2a. Main valve
3. Gas pressure switch, min.
4. Gas pressure switch, VPS
- 2b. Safety valve
5. Pressure regulator
6. Gas damper
7. Gas pressure switch, max.
8. Air pressure switch

3. Electric equipment

3.1 Safety system

The safety system (safety switch for hatches, doors, water level, pressure, temperature and other safety devices) must be installed in the safety circuit in accordance with current regulations for the system. If these safety requirements are met by other means, safety circuits must be bypassed. This can differ between different systems in which the burner is installed, see rules and regulations that apply.

The cables of the safety system must be separated so that the outgoing signal is not placed in the same cable as the incoming signal.

3.2 Components

A1	Automatic control unit LMV	S10	Gas pressure switch, max
B1	Ionization electrode	S17	Gas pressure switch, VPS
F1	Fuse	T1	Ignition transformer
K1	Contactor + Overload protection	X53	Connection, Damper motor - Air
M1	Motor	X54	Connection, Damper motor - Gas
S1	Operation switch	X56	Connection, Display
S7	Main switch	Y1	Solenoid valve 1
S8	Air pressure switch	Y2	Solenoid valve 2
S9	Gas pressure switch, min		



! The installation of a safety system is required to start the burner.

! Mains connection and fuse in accordance with local regulations.

3.3 Wiring diagram

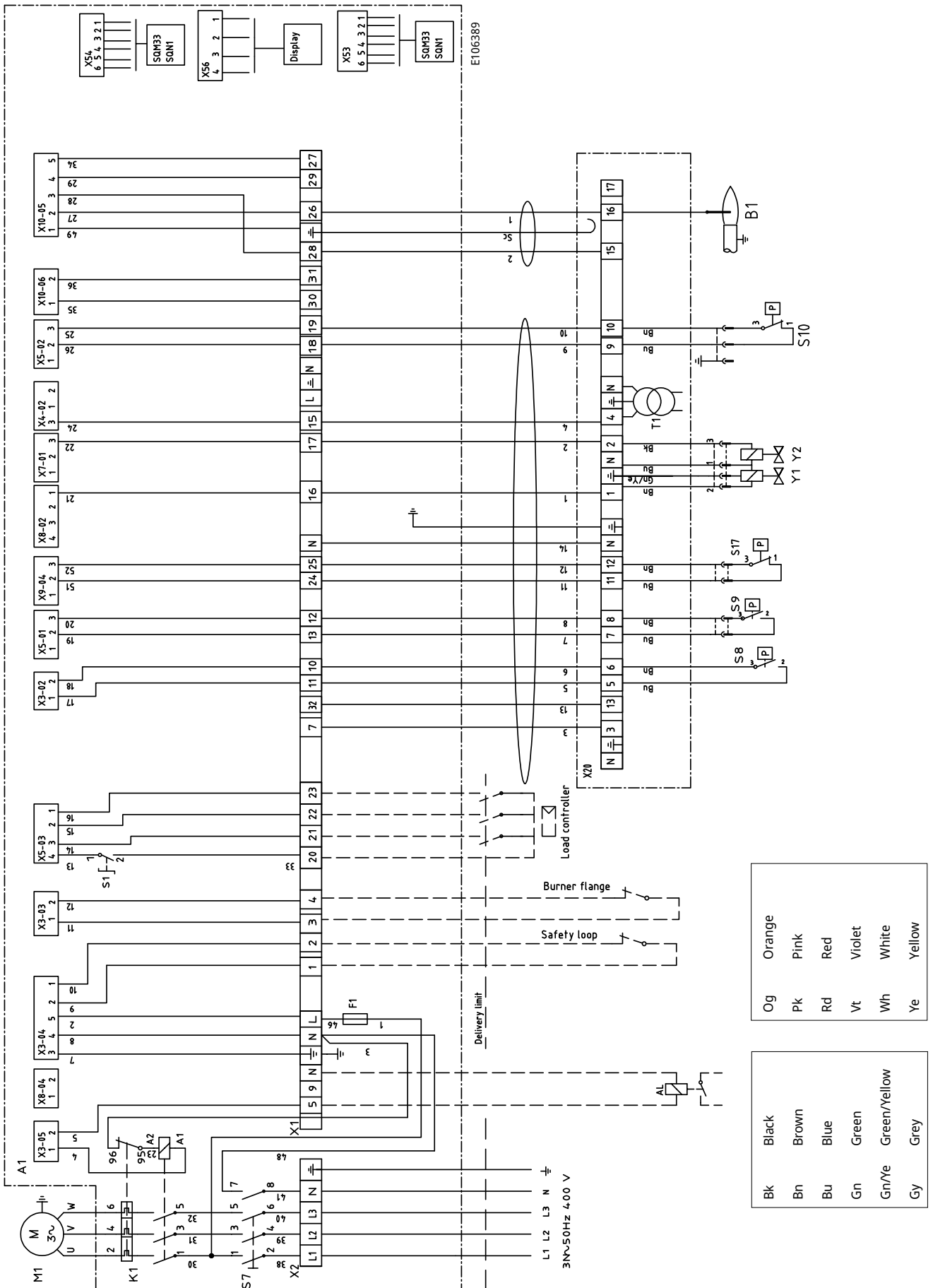

4. Automatic control unit LMV37

The LMV37 Automatic control unit is a piece of control equipment that can be used for many different types of burner.

In the following review of how this control equipment works and can be adjusted, the description will focus on the type of burner covered by this

4.1 System structure/Function description

The LMV37.4... is a microprocessor-based burner management system with matching system components for the control and supervision of forced draft burners of medium to high capacity.

Integrated in the basic unit of the LMV37.4... are:

- Burner management system complete with valve proving system
- Electronic air-fuel ratio control system for a maximum of 2 SQM3... or SQN1... actuators
- Control of VSD air fan
- Modbus interface

At the time of writing, of the parameters mentioned above, motor frequency control and communication via modbus are not available on the burner models described in this manual.

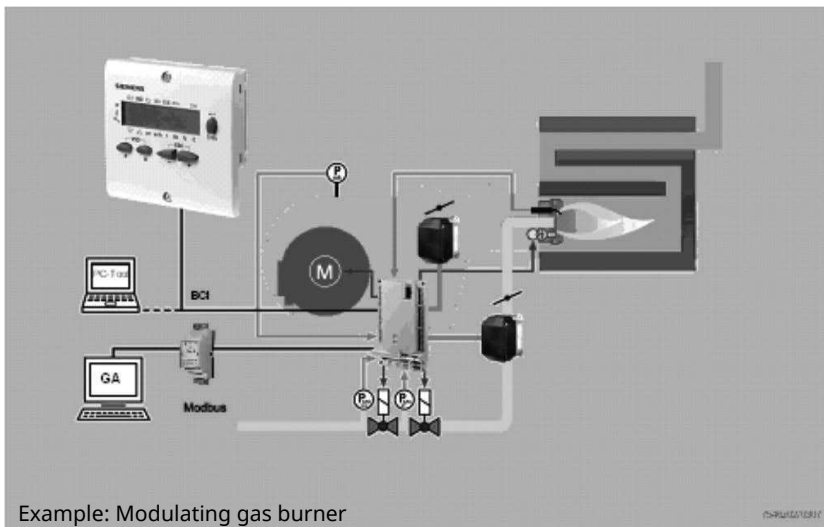

The system components (display and operating unit, actuators) are connected directly to the LMV37.4... basic unit. All safety-related digital inputs and outputs of the system are monitored by a contact feedback network.

4.2 General information

The burner management system is operated and parameterized via the AZL2... display. The AZL2... with LCD and menu-driven operation facilitates straightforward use and targeted diagnostics. When making diagnostics, the display shows the operating states, the type of error and the point in time the error occurred. Passwords protect the different parameter levels of the burner against unauthorized access. It is possible to select from different types of fuel trains and make use of a wide choice of individual parameter settings (program times, configuration of inputs / outputs, etc.), enabling the installer to make optimum adaptations to the relevant application. A change of parameters varies in levels of authorization, this manual will give info on those that might be changed by the installer. The actuators are driven by stepper motors and can be positioned with high resolution. Specific features and actuator settings are defined by the LMV37.4... basic unit.

4.3 Technical data Basic unit LMV37.4...

Mains voltage	
LMV37.400A2	AC 230 V -15 % / +10 %
Mains frequency	50 / 60 Hz \pm 6 %
Safety class	I, with parts according to II and III to DIN EN 60730-1
Perm. mains primary fuse (externally)	Max. 16 AT
Unit fuse F1 (internally)	6.3 AT (DIN EN 60127 2 / 5)
Mains supply: Input current depending on the operating state of the unit	

Under voltage	
Safety shutdown from operating position at mains voltage	
LMV37.400A2	Approx. AC 186 V
Restart on rise in mains voltage	
LMV37.400A2	Approx. AC 195 V

Gas direct ignition «G», «G mod», «G mod pneu»

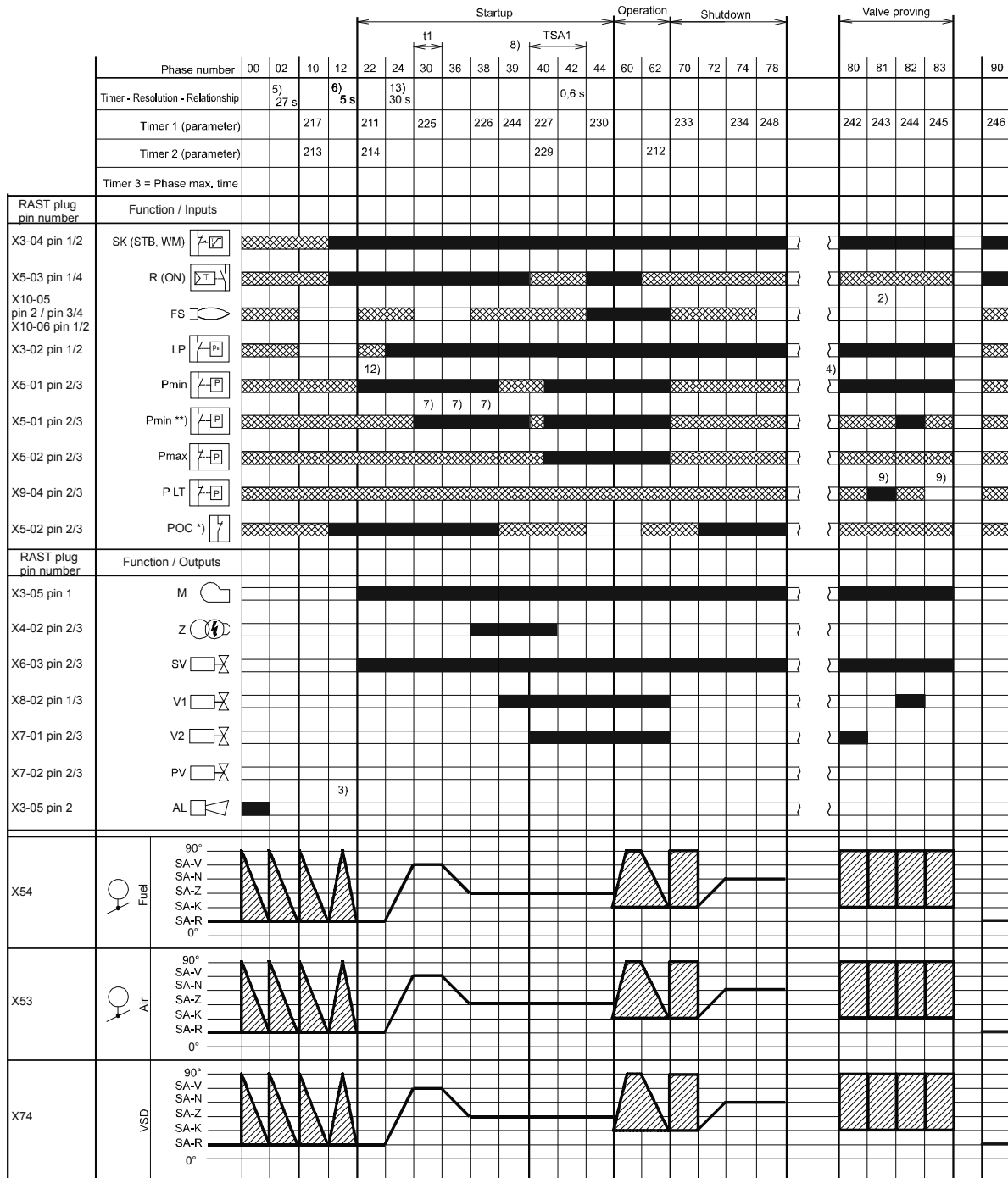

Legend to the sequence diagrams



Not all phases, times, indices, abbreviations and symbols appear in the individual sequence diagrams or are needed there!

Phase numbers	
00	Lockout phase
02	Safety phase
10	Home run
12	Standby (stationary)
22	Fan motor (M) = ON, safety valve (SV) = ON
24	Air damper (LK) \rightleftharpoons fuel valve prepurge position
30	Prepurging
36	Air damper (LK) \rightleftharpoons ignition position
38	Preignition ignition (Z) = ON
39	Test pressure switch-min (Pmin)
40	Fuel valve (V) = ON
42	Ignition (Z) = OFF
44	Interval 1 (t44)
50	Safety time 2 (TSA2)
52	Interval 2 (t52)
60	Operation 1 (stationary)
62	Operation 2 air damper (LK) \rightleftharpoons low-fire (KL) - position
70	Afterburn time (t13)
72	Air damper (LK) \rightleftharpoons Rated load (NL) - position
74	Postpurge time (t8)
78	Postpurge time (t3)
80	Evacuation of test space
81	Atmospheric pressure test
82	Filling of test space
83	Gas pressure test
90	Gas shortage waiting time

Valve proving is performed depending on the parameter settings:

Simultaneously with the prepurge time and/or the afterburn time.

Times	
TSA1	1st safety time
TSA2	2nd safety time
t1	Prepurge time
t3	Postpurge time
t8	Postpurge time
t13	Afterburn time
t44	Interval 1
t52	Interval 2

Indices	
1)	Parameter: Short/long prepurge time for oil only Short/long on time of oil pump - time
2)	Only with valve proving during startup
3)	Parameter: With/without alarm in the event of start prevention
4)	If signal is faulty in the startup phase, phase 10 is next, otherwise phase 70
5)	Max. time safety phase, then lockout
6)	Time from occurrence of start prevention to signaling
7)	Only in case of valve proving during startup (valve proving via pressure switch-min)
8)	Only in case of startup without valve proving (valve proving via pressure switch -min)
9)	Inverse logic in case of valve proving via pressure switch-min
10)	Parameter: Oil pressure min-input 1 = active from phase 38 2 = active from safety time
11)	Only with fuel train Lo and 2 fuel valves
12)	Parameter 223: Repetition limit value gas pressure switch-min in connection with gas shortage program parameter 246 (phase 90)
13)	Max. drop-in/response time for air pressure switch
14)	Alternative to valve proving
15)	Alternative to pressure switch-max (Pmax) or POC

Abbreviations	
AL	Alarm
FS	Flame signal
GM	Fan motor contactor
LP	Air pressure switch
M	Fan motor
P LT	Pressure switch for valve proving
Pmax	Pressure switch-max
Pmin	Pressure switch-min
POC	Proof of closure
PV	Pilot valve
R	Temperature or pressure controller
SB	Safety limiter
SK	Safety loop

STB	Safety limit thermostat
SV	Safety valve
WM	Water shortage
V1	Fuel valve 1
V2	Fuel valve 2
VP	Combustion pressure switch
Z	Ignition transformer

SA	Actuator
SA-K	Low-fire position of actuator
SA-N	Postpurge position of actuator
SA-R	Home position of actuator
SA-V	Rated load position of actuator
SA-Z	Ignition load position of actuator

Symbols



Permissible position range



In Standby mode: Actuator is allowed to travel within the permissible position range, but is always driven to the home position; must be in the home position for phase changes

0°/10% Position as supplied (0°)
90°/100% Actuator fully open (90°)



Input/output signal 1 (ON)



Input/output signal 0 (OFF)



Input permissible signal 1 (ON) or 0 (OFF)

4.4 Connection and internal diagram

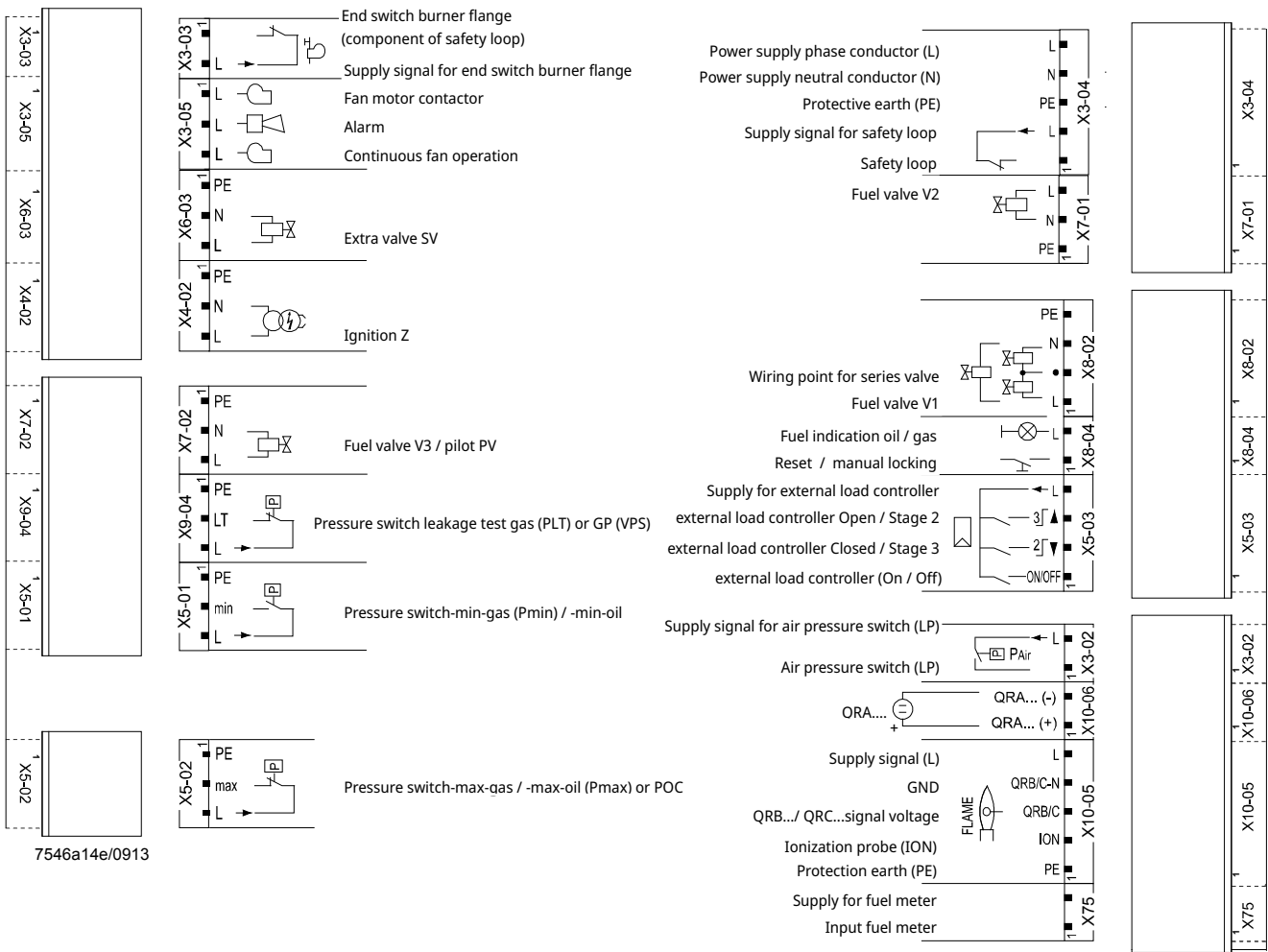

Shielding:

For shielding the cables on the VSD, refer to:

- Siemens SED2 VSD Commissioning Manual (G5192), chapters 4 and 7, or
- Danfoss Operation Manual VLT 6000 (MG60A703), chapter Installation

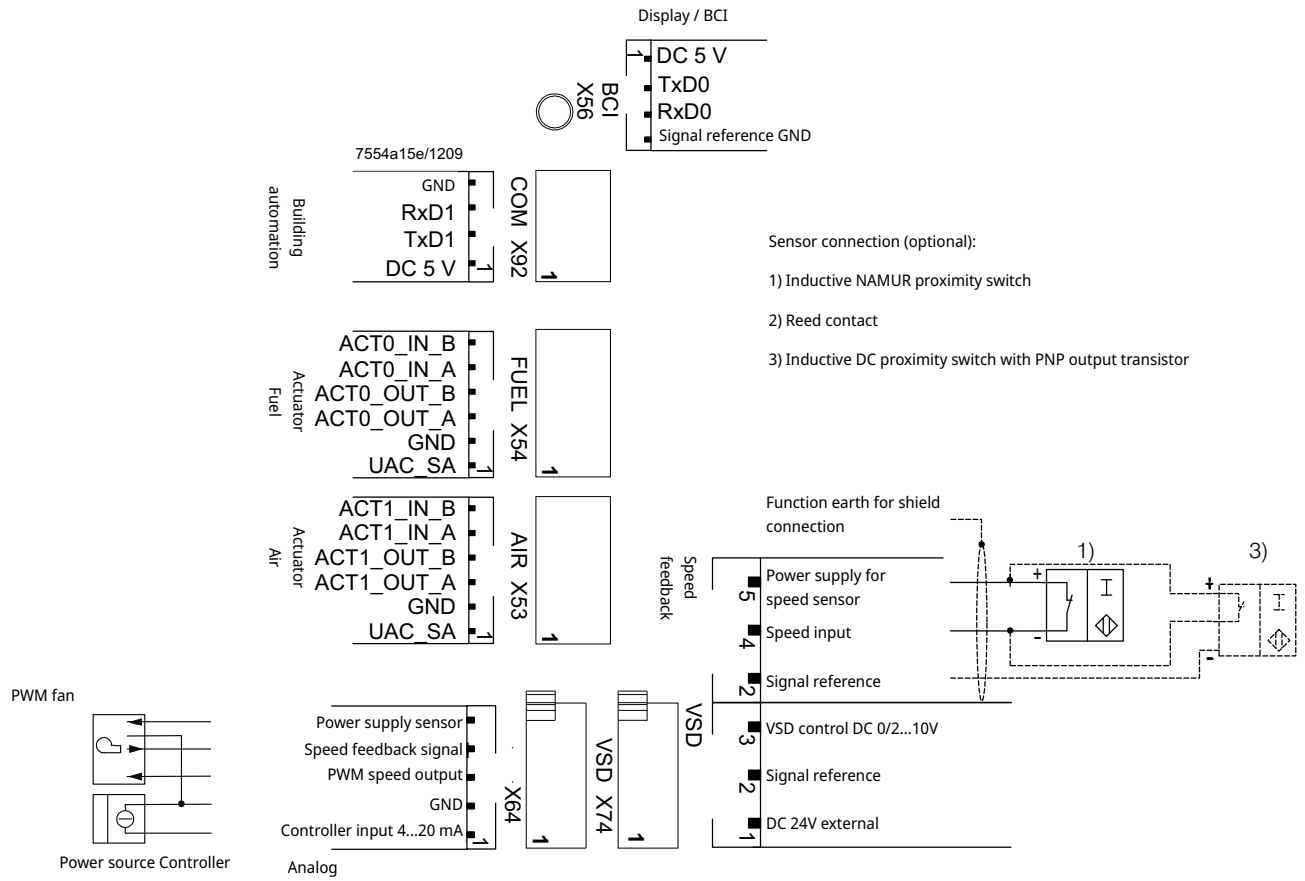

5. Operation

5.1 LMV37 automatic control unit

5.1.1 Explanation of display and buttons

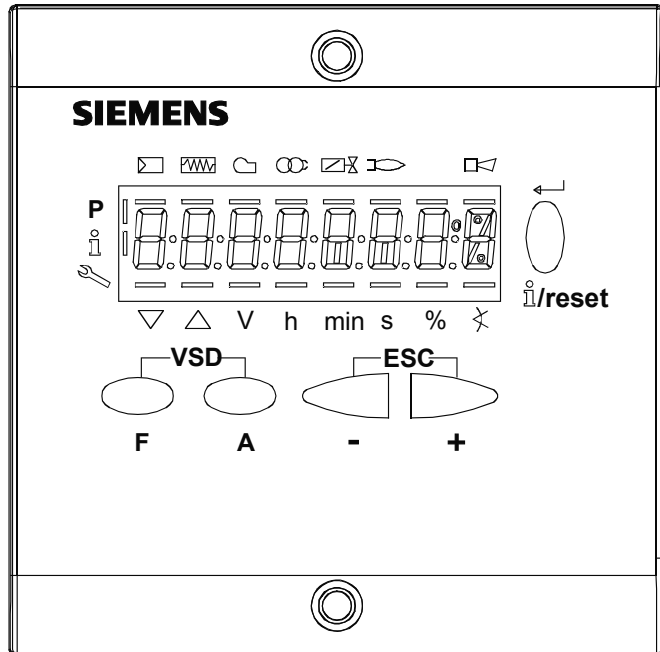
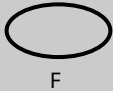



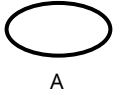



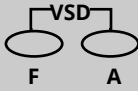

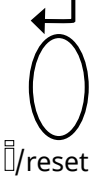

Figure 3: Description of unit/display and buttons

Button	Function
	<p>Button F</p> <p>- For adjusting the fuel actuator</p> <p>(keep  depressed and adjust the value by pressing  or .</p>
	<p>Button A</p> <p>- For adjusting the air actuator</p> <p>(keep  depressed and adjust the value by pressing  or .</p>
	<p>Buttons A and F: VSD function</p> <p>- For changing to parameter setting mode P</p> <p>(press simultaneously  and .</p>
	<p>Info and Enter button</p> <ul style="list-style-type: none"> • For navigating in info or service mode <ul style="list-style-type: none"> - Selection (symbol flashing) (press button for <1 s) - For changing to a lower menu level (press button for 1...3 s) - For changing to a higher menu level (press button for 3...8 s) - For changing the operating mode (press button for >8 s) • Enter in parameter setting mode • Reset in the event of fault • One menu level down





Button	Function
	<p>- button</p> <ul style="list-style-type: none"> For decreasing the value For navigating during curve adjustments in info or service mode
	<p>+ button</p> <ul style="list-style-type: none"> For increasing the value For navigating during curve adjustments in info or service mode
	<p>+ and - button: Escape function (press  and  simultaneously)</p> <ul style="list-style-type: none"> No adoption of value One menu level up

Figure 4: Meaning of display



5.2 List of phase displays

The display shows which phase the burner is in. The table below lists the codes and explains what these mean for the various phases. Not all the phases described in the table are shown or are suitable for the burners described in this manual.

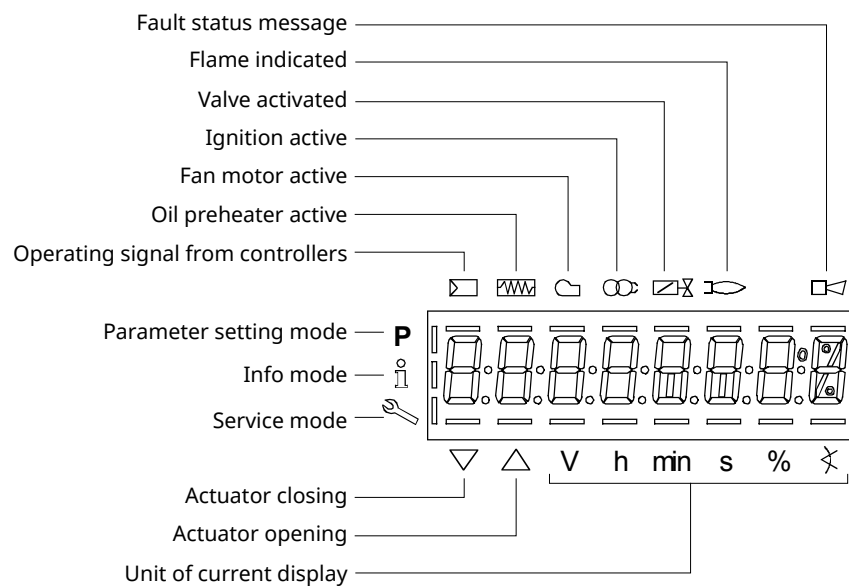
Phase	Function
Ph00	Lockout phase
Ph01	Safety phase
Ph10	Home run
Ph12	Standby (stationary)
Ph22	Fan ramp up time (fan motor = ON, safety valve = ON)
Ph24	Traveling to the prepurge position
Ph30	Prepurge time
Ph35	Fan
Ph36	Traveling to the ignition position
Ph38	Preignition time
Ph39	Valve proving filling time (test of pressure switch-min when fitted between fuel valves V1 and V2)
Ph40	1st safety time (ignition ON)
Ph42	1st safety time (ignition OFF)
Ph44	Interval 1
Ph50	2nd safety time
Ph52	Interval 2
Ph60	Operation 1 (stationary)
Ph62	Max. time low-fire (operation 2, preparing for shutdown, traveling to low-fire)
Ph64	Switching back to pilot: Modulation to ignition load
Ph65	Switching back to pilot: Interval 2 waiting time
Ph66	Switching back to pilot: Reactivation of ignition + pilot
Ph67	Switching back to pilot: Shutdown of main valves
Ph68	Switching back to pilot: Pilot mode waiting phase
Ph69	Switching back to pilot: Pilot mode waiting phase for burner startup
Ph70	Afterburn time
Ph72	Traveling to the postpurge position
Ph74	Postpurge time (no extraneous light test)
Ph78	Postpurge time (t3) (abortion when load controller ON)
Ph80	Valve proving test evacuation time
Ph81	Valve proving test time atmospheric pressure, atmospheric test
Ph82	Valve proving filling test, filling
Ph83	Valve proving time gas pressure, pressure test
Ph90	Gas shortage waiting time

5.3 Automatic control unit levels

When working on burners there are different levels at which the automatic control unit can be accessed.

The info and service levels can be accessed without a password; error codes, error history and basic information about the burner can be viewed on these levels.

A code is required to enter settings for the burner.

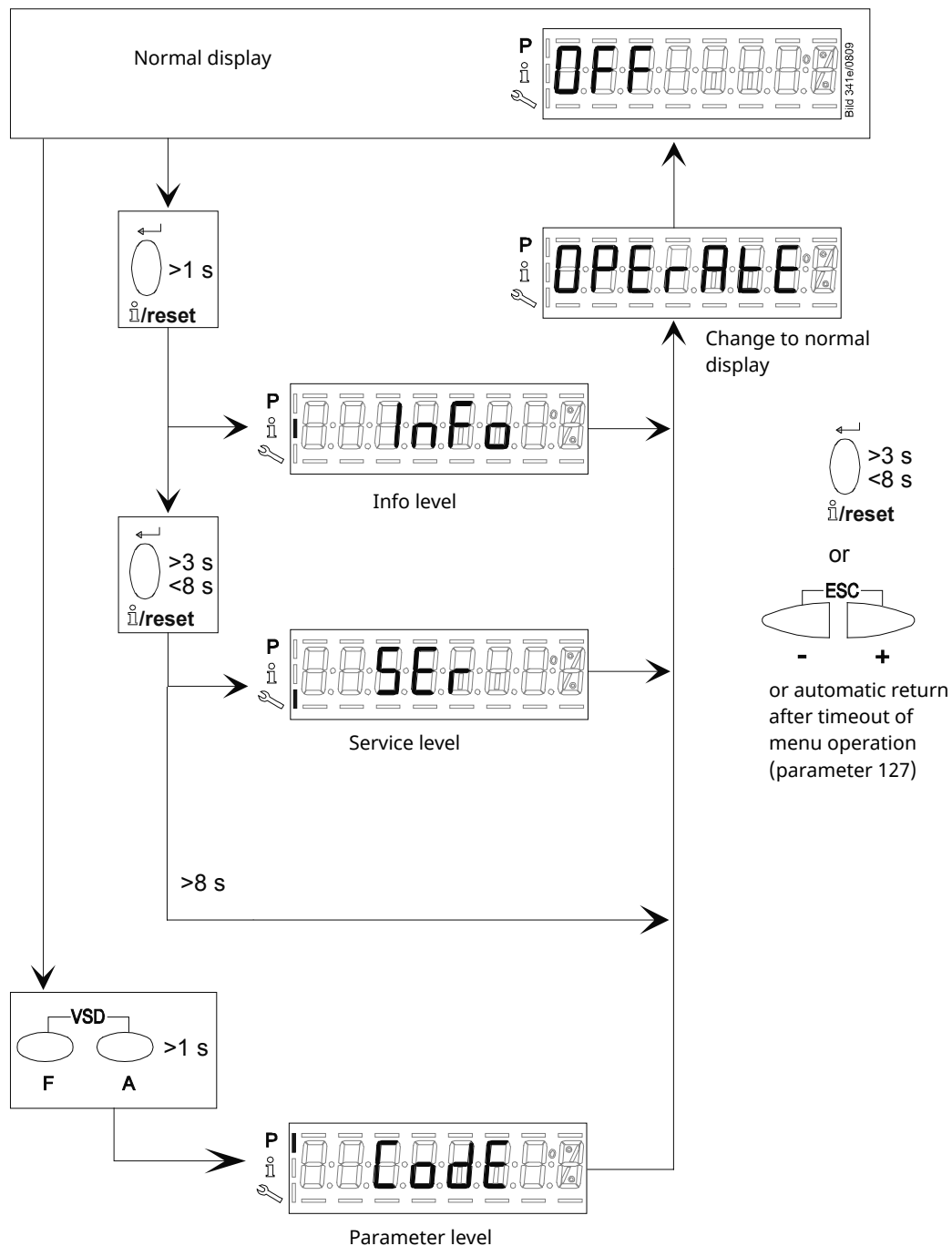

5.3.1 Structure of parameter levels

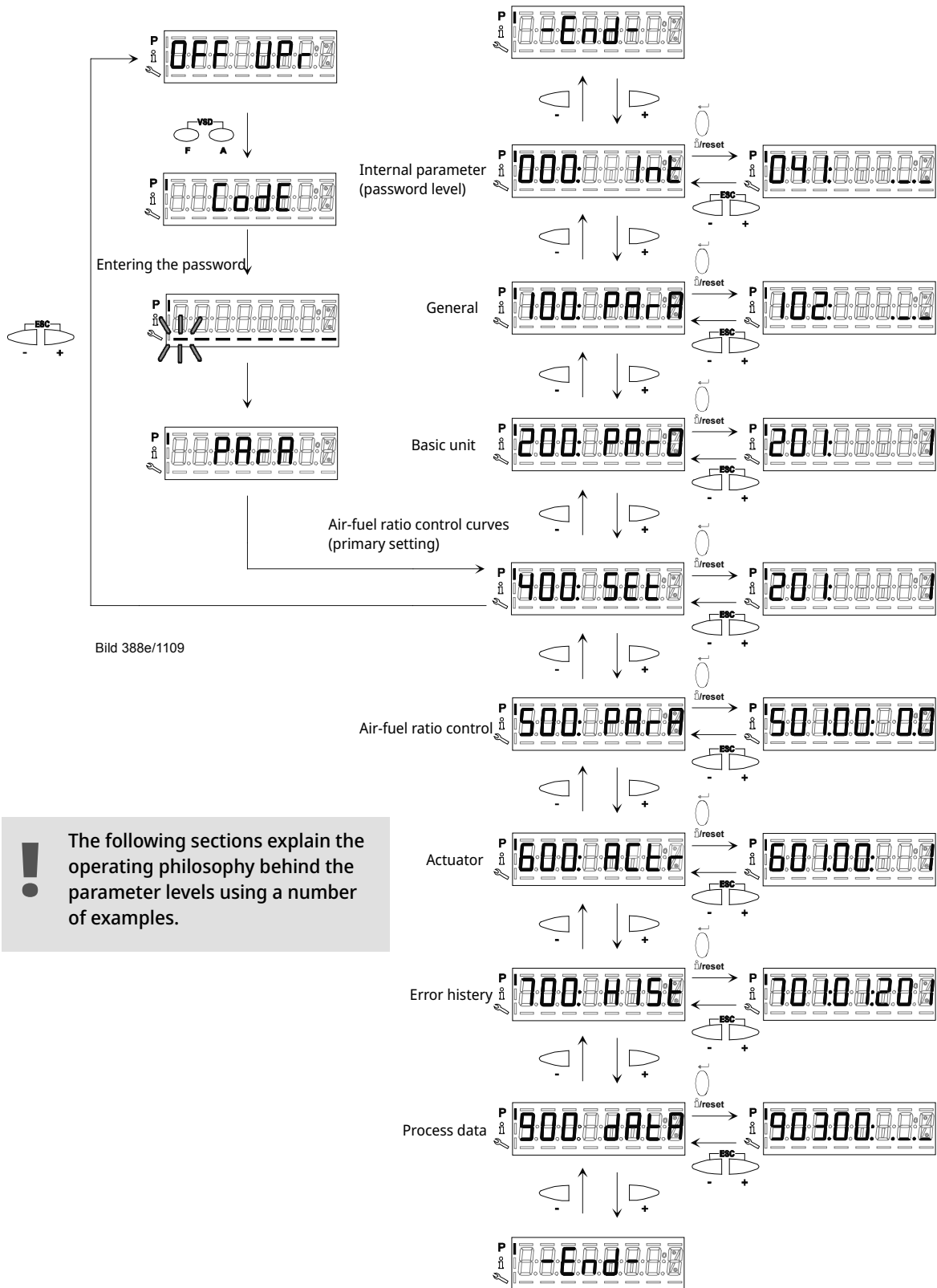

5.3.2 Parameter of level info

No.	Parameter
167	Fuel volume resettable (m ³ , l, ft ³ , gal)
162	Operating hours resettable
164	Startups resettable
163	Operating hours when unit is live
166	Total number of startups
113	Burner identification
107	Software version
108	Software variant
102	Identification date
103	Identification number
104	Preselected parameter set: Customer code
105	Preselected parameter set: Version
143	Reserve
End	

5.3.3 Parameter of level service

No.	Parameter
954	Flame intensity
960	Actual flow rate (fuel throughput in m ³ /h, l/h, ft ³ /h, gal/h)
121	Manual output Undefined = automatic operation
922	Incremental position of actuators Index 0 = fuel Index 1 = air
936	Standardized speed
161	Number of faults
701	Error history: 701-725.01.Code ex. 701. 01. xxx · · · 725

Indexlista:

01 = error code

02 = diagnostic code

03 = error class

04 = error phase



05 = startup counter

06 = output

5.3.4 Access code for service engineer level



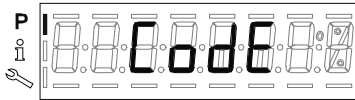

The code for logging into service level is found on the plate on the inside of the cover for the electrical connections box.

Press button combination    to display **Code**

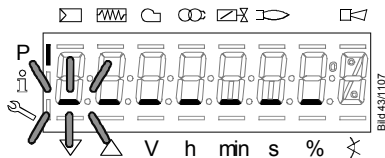

When releasing the buttons, 7 bars appear the first of which is flashing.



Press  or  to select a number or letter.

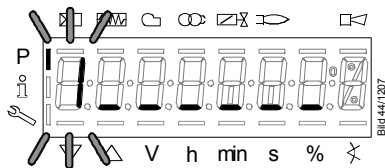

Press  to confirm the value

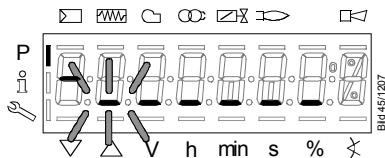

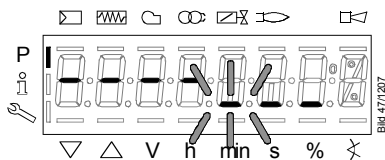

The value entered changes to a minus sign (-)
The next bar starts flashing.

Complete the rest of the password according to the principle described.



Example: Password consisting of 4 characters.

After entry of the last character the password must be confirmed by pressing  

5.4 Manual output

A manual output can be set with the «Normal display» of the display and operating unit.

5.4.1 Activation of Manually OFF in standby via the display and operating unit

When the burner is in OFF position it can be set to Manually OFF which means that the burner will not start.

Manual OFF can be activated by pressing  for at least 1 second then **LoAd 0.0** appears flashing.

LoAd 0.0 means Manually OFF.

As long as the Manual OFF is active, **OFF** appears on the normal display flashing.

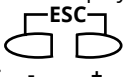

To deactivate and to change to automatic operation, press  for 3 seconds. Then OFF appears without flashing in the display.

5.4.2 Activation of Manually OFF in operation and adjustment of output via the display and operating unit

When the burner is in operation position it can be set to Manually OFF which means that the load of the burner can be manually set and will not start if the burner is shut down.

To activate Manually OFF, first run the system to the minimum output limit.

Manual OFF can be activated by pressing  for at least 1 second then **LoAd 0.0** appears flashing.

Adjustment of **LoAd** can now manually be done by pressing  and simultaneous pressing  or .

The burner will now stay in set input if none of the safety regulators stops the burner.

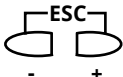
To deactivate and to change to automatic operation, press  for 3 seconds.

! If Manually OFF is activated, it is stored via mains OFF.

● On power return, the burner assumes the Manually OFF position (OFF flashing).

! Please note that the automatic control unit will not exit manual mode by itself. Make sure that the automatic control unit is reset to automatic mode.

! The unit can be changed to manual mode without login taking place. If the automatic control unit has been left in manual mode, no automatic burner control will take place, which in turn means that the installation is not operating satisfactorily. For this reason, make sure when servicing/troubleshooting that the automatic control unit is not in manual mode.

! Manually OFF must not be used just to put a burner out of operation when doing mounting work, or when the burner is not ready for operation. The safety notes contained in chapter Safety notes must be observed!

5.5 Setting the automatic control unit

To set the correct ratio between air and fuel, it is important to understand how this type of burner is controlled. This chapter will describe the procedure to follow when adjusting a burner with an LMV37 automatic control unit.

! Note! When power is turned on for an unadjusted automatic control unit, "OFF UPr" is always shown in the display.

5.5.1 Adjusting settings of previously set automatic control unit

The burner is pre-set at the factory for start-up.

! With the warm settings, the burner is started up after pressing the Info button. Air-fuel ratio control can now be accurately set while the flame is present. When traveling along the precalculated curve to curve point **P9**, all intermediate curvepoints (**P2...P8**) must be set. Automatic operation is released when – after reaching **P9** – the curve settings are quit by pressing ESC. If the curve settings are aborted earlier (**ESC** or shutdown due to fault), start prevention **OFF UPr** continues to be active until all points are set. If required, the gas pressure can be set at the high curve point. In case the gas pressure is changed, all points must be checked by traveling along the curve downward and – if required – must be readjusted. safety shutdown, parameterization of the curve is quit.

- Check that the burner is connected to gas and has gas pressure.
- Check that the burner is electrically connected.
- Move the switch to the ON position (I).

The display on the burner will now be active.

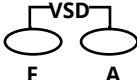

Follow the description below to set the burner.

Press  > 1 second to access login mode.

To continue with the setting work, you need to log into service engineer level, see section "Access code for service engineer level".

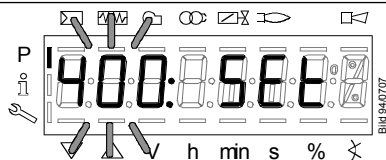
After login is complete, continue with the setting work as shown below.



Press  to select parameter **400** for initial commissioning and for setting air-fuel ratio control
/reset

Identification of start for setting the curve parameters.

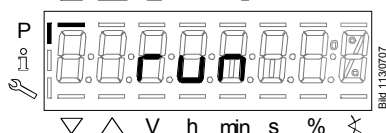





Curve points are displayed.





! If, during the time the curve is parameterized, an error occurs which leads to safety shutdown, parameterization of the curve is quit.

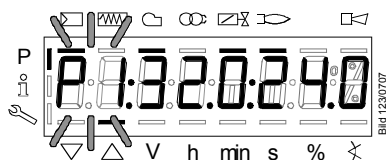

The startup process on the automatic control unit now takes place.



When the automatic control unit has completed the start procedure and the burner has started, the setting values for curvepoint 1 will appear; settings for the minimum input power will be shown in the display. See display representation below. If you wish to adjust the ignition load, this can be done by pressing  when curvepoint 1 is shown in the display.

Curve point **P1** can only be set when symbol  or  is no longer highlighted. The value is adopted from **P0**, (fine-tuned in later step).





For fuel, keep  depressed, for air . Press  and  to adjust the value. F A

When symbol  or  is no longer highlighted, the next curvepoint can be selected with .



To the next curvepoint  back to the previous curvepoint .

! Curvepoint 1 should be set to the minimum input power that the installation can handle. Curvepoint 9 should be set to the maximum input power that the installation can handle. Once the curve setting is complete, the desired minimum and maximum input power can be set.

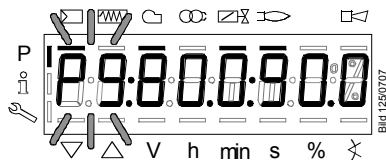

Set curve point **P9** and pressure regulator:

Curve point **P9** can only be set when symbol  or  is no longer highlighted. Adjust the incoming gas pressure if necessary.



For fuel, keep  depressed, for air,  F A

Press  and  to adjust the value.

When symbol  or  is no longer highlighted, the curve is set and it is possible to go on with the rest of the setting.

After setting **P9**, the remaining curve points are set in reverse order **P8** to **P1** and then **P0** is set to obtain a good start.

After setting the curve point (P0), you can either switch to parameter 546 (automatic operation) (with ESC) or run through all curve points in reverse order.

If the gas pressure is changed, all curvepoints must be checked and - if required - readjusted.

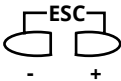
Press .





If  is pressed before **curve points are completed**, the burner is switched off and the automatic control unit enters **OFF UPr** mode.

The maximum capacity is displayed.

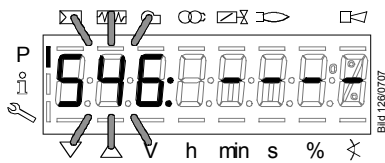
If the display shows - - - -, the maximum capacity has not yet been specified. The system can be run up to 100% capacity.



You can press  to go to editing mode, enabling you to change the maximum capacity.

Adjust the setting downwards or upwards using the buttons .

Press  to save the setting.

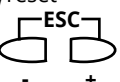
Press  to return to parameter level **400 Set**.

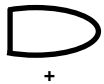

To the next parameter.

The minimum capacity is displayed.

If the display shows - - - -, the minimum capacity has not yet been entered. The system can be run down to 20% capacity.

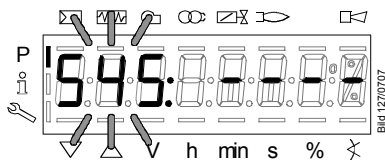

You can press  to go to editing mode, enabling you to change the minimum capacity.

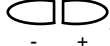
Adjust the setting downwards or upwards using the buttons .

Press  to save the setting.

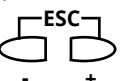
Press  to return to parameter level.

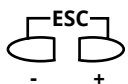

Completing parameterization of the curve



Back to the previous parameter

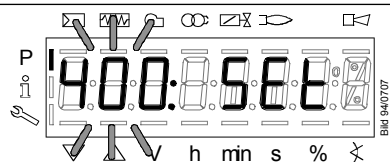

When symbol \triangle or ∇ is no longer highlighted, you can press **ESC** a second time.

Press .

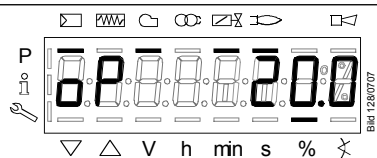

The warm settings for air-fuel ratio control by the LMV37.4... are now completed.

5.5.2 Setting an automatic control unit which has not previously been set or lost its settings

! Note! When power is turned on for an unadjusted automatic control unit, "OFF UPr" is always shown in the display.



- Check that the burner is connected to gas and has gas pressure.
- Check that the burner is electrically connected.
- Move the switch to the ON position (I).

The text "OFF UPr" is shown in the display.

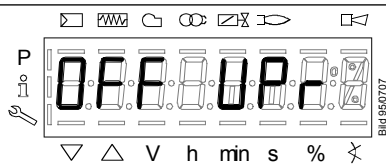
Follow the procedure indicated below to set the automatic control unit.





An unprogrammed unit or a unit whose operating mode has been reset or changed displays **OFF UPr**.

Press   > 1 second to access login mode.

To continue with the setting work, you need to log into service engineer level, see section "Access code for service engineer level".

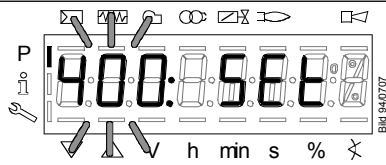
After login is complete, continue with the setting work as shown below.



Press  to select parameter **400** for initial commissioning and for setting air-fuel control.
/reset

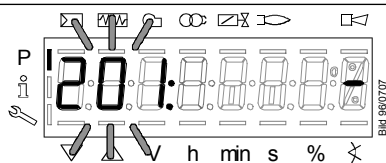

201: appears flashing.

Press to go to the settings for air-fuel ratio control and parameter

201 for selecting the operating mode.



Ensure that the fuel train is correctly set in compliance with the type of burner used.

No	Parameter	Actuator controlled	
		Air	Fuel
201	Burner operating mode (fuel train, modulating / multistage, actuators, etc.)	Air	Fuel
	-- = undefined (delete curves)	•	•
	1 = gas modulating (G mod)	•	•
	2 = gas modulating with pilot valve (Gp1 mod)	•	•
	3 = gas modulating with pilot valve (Gp2 mod)	•	•
	4 = oil modulating (Lo mod)	•	•
	5 = oil 2-stage (Lo 2 stage)	•	-
	6 = oil 3-stage (Lo 3 stage)	•	-
	7 = gas modulating (G mod pneu)	•	-
	8 = gas modulating (Gp1 mod pneu)	•	-
	9 = gas modulating (Gp2 mod pneu)	•	-
	10 = oil modulating with gas pilot (LoGp mod)	•	•
	11 = oil 2-stage with gas pilot (LoGp 2-stage)	•	-
	12 = oil modulating with 2 fuel valves (Lo mod 2V)	•	•
	13 = oil modulating with gas pilot and 2 fuel valves (LoGp mod 2V)	•	•
	14 = gas modulating (G mod pneu, 0 active)	-	-
	15 = gas modulating with pilot (Gp1 mod pneu, 0 active)	-	-
	16 = gas modulating with pilot (Gp2 mod pneu, 0 active)	-	-
	17 = oil 2-stage (Lo 2-stage, 0 active)	-	-
	18 = oil 3-stage (Lo 3-stage, 0 active)	-	-
	19 = gas modulating only when firing on gas (G mod fuel active)	-	•
	20 = gas modulating with pilot only when firing on gas (Gp1 mod fuel active)	-	•
	21 = gas modulating with pilot only when firing on gas (Gp2 mod fuel active)	-	•
	22 = oil modulating only when firing on oil (Lo mod fuel active)	-	•



This manual describes "1=gas modulating (Gmod)" type burners.

Press: to return to parameter level.

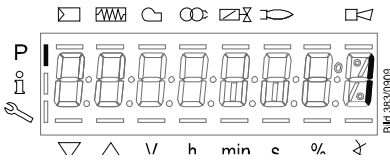

Press to save selected setting.
/reset

Press: to return to parameter level.

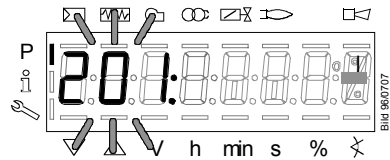

To the next parameter .

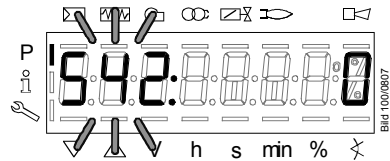

Parameter **542**
 activate the VSD / PWM fan.
 You can choose:
 0 = VSD / PWM fan OFF
 1 = VSD / PWM fan ON

If the parameter is set correctly, move directly to the next parameter with .

Press to adjust parameter **542**.
/reset

Select your setting by pressing one of the buttons .

Press to save the setting for parameter **542**: VSD
/reset

Press: to return to parameter level.

To the next parameter . Back to the previous parameter .



This manual describes "0=VSD OFF" type burners.

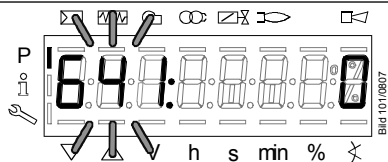

Parameter **641** to control speed standardization of the VSD.

You can choose:

0 = speed standardization of VSD OFF

1 = speed standardization of VSD ON

After setting speed standardization to 1, standardization of the VSD commences. If successful, the parameter is reset to 0. Negative values indicate errors (refer to chapter Automatic speed standardization).

If the parameter is set correctly, move directly to the next parameter with .

Press: to adjust parameter **641**: speed standardization
/reset

Select your setting by pressing one of the buttons .

Press: to save the setting for parameter **641**: VSD
/reset

Press: to return to parameter level.

! This manual describes "0=speed standardization" type burners.

To the next parameter .

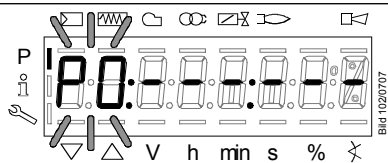

Display **P0** appears flashing.

Curvepoint for ignition load.

Press simultaneously and or to set ignition position **P0** of the fuel damper.

! Set a suitable fuel-air mixture so that the burner starts.

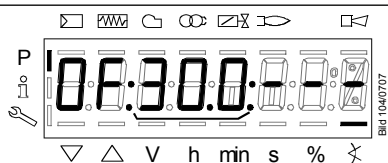

Example: **30.0**

Press simultaneously and or to set ignition position **P0** of the air actuator.

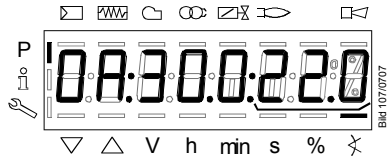

Example: 22.0

Press simultaneous **F** and **A** and **-** or **+** to adjust speed **nO** of the load controller.

! This menu option is only shown if parameter 542 has been set to 1, for burners with VSD.
● This manual only describes burners without VSD.

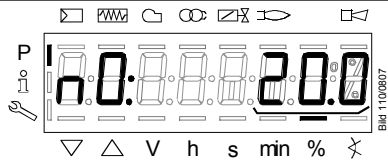

Example: 20.0

To the next curvepoint **+**.

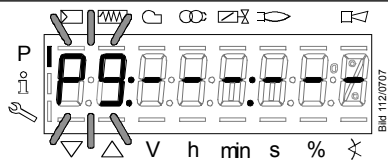

P9 appears flashing.

Curvepoint for high-fire.

Same procedure as with **P0**

! Note:
● If **-** is pressed first, the display jumps to 90!

Back to the previous curvepoint **-**.

When curvepoint **P9** is set, press **+** and Enter to start the burner.

Example of basic setting

Basic settings should only be seen as setting values to get burner to start. Once the burner has started and established flame, it is necessary to adjust the settings so that they are adapted to the installation and the fuel used.

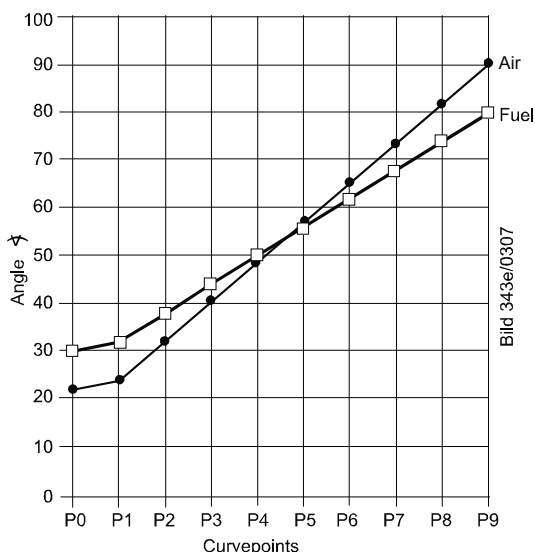

It is important to set **P0** and **P9** as accurately as possible. These settings are used to calculate the remaining curvepoints once the burner has started.

Curvepoints P2 to P8 are automatically computed as a straight line between P1 and P9.

Example 1 = gas modulating

	Curvepoint	Value 1 fuel	Value 2 air
P0, P1 and P9 are set as described	P0	30.0	22.0
	P1	32.0	24.0
	P9	50.0	90.0

Curvepoint **P1** is automatically set to the same value as **P0** on the first start. This value can, however, be adjusted once the burner has started.

	Curvepoint	Value 1 fuel	Value 2 air
P2 through P8 have automatically been calculated:	P2	38.0	32.3
	P3	44.0	40.5
	P4	50.0	48.8
	P5	56.0	57
	P6	62.0	65.3
	P7	68.0	73.5
	P8	74.0	81.8

To simplify the setting work involved for each curvepoint, do as follows:

1. Check that good combustion is achieved at **P1**; adjust if necessary.
2. Move along to **P2** and check/adjust for good combustion.
3. Calculate the curvepoints between **P2** and **P9** by pressing > on .
4. Now move along to **P9** and repeat the process described.
5. Repeat the process until curvepoint **P1** has been reached. This method makes the setting work easier and faster to complete. A more "correct" setting is obtained straight away. The process may need to be redone if the wrong input power was set for **P9** initially. For this reason, be extremely careful when entering the first setting of **P9**.

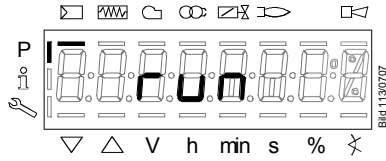

Identification of start for setting the curve parameters.

Press to continue.
 /reset

The burner motor will then start and a number of phases in the automatic control unit are completed. A menu then appears, asking whether further changes to ignition load **P0** need to be made.

If the switch on the burner is in the OFF position, the automatic control unit will not proceed from **Ph12**: Move the switch to the **ON** position to continue.

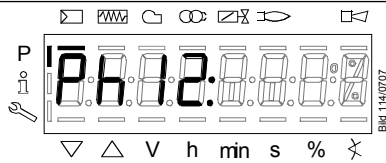

Phase Standby (stationary)

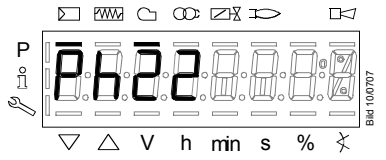

Phase Fan ramp up (fan motor = ON, safety valve = ON)



Phase Traveling to prepurge position



VPS Leakage control



Phase Prepurging



Phase Traveling to ignition position

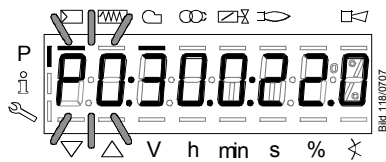

Ignition position **P0** can only be set after symbol Δ or ∇ is no longer highlighted.

For fuel, keep depressed, for air ,

press or to adjust the value.

When the symbol Δ or ∇ is no longer highlighted,

press to continue.

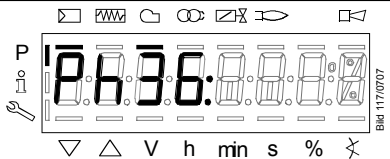

Phase Traveling to ignition position



Phase Preignition

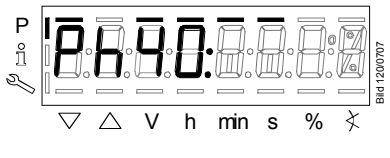

Phase for first safety time (ignition transformer ON)

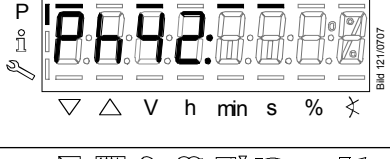

Phase for first safety time (ignition transformer OFF), preignition time OFF

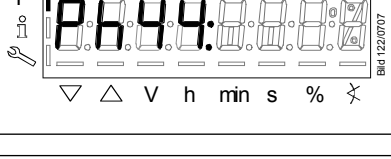

Phase Interval 1



The burner has ignited and is burning. Should the burner not ignite, repeat the above procedure but adjust ignition load **P0** to get the burner to start.

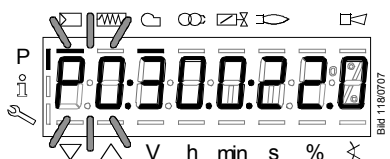

The **P0** menu will appear when the burner starts successfully.

It is now possible to adjust ignition load **P0** while the burner is in operation.



Ignition position **P0** can only be set when symbol Δ or ∇ is no longer highlighted.

For fuel, keep  depressed, for air, 

press  or  to adjust the value.

When the symbol Δ or ∇ is no longer highlighted, press  to continue to the next curvepoint.

Curve point **P1** can only be set when symbol Δ or ∇ is no longer highlighted.

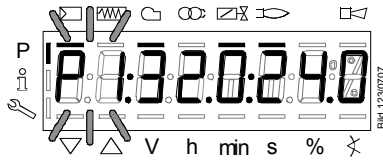

The value is adopted from **P0**

For fuel, keep F depressed, for air, A
 press $-$ or $+$ to adjust the value.

When symbol Δ or ∇ is no longer highlighted.

Back to the previous curvepoint $-$.

When the symbol Δ or ∇ is no longer highlighted, press $+$ to start calculating curvepoints.

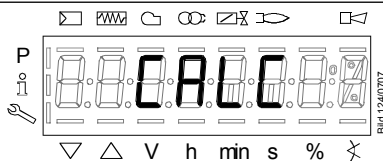

When changing from **P1** to **P2** for the first time, curvepoints **P2...P8** automatically calculated and saved.

CALC appears for a short moment.

After setting **P9**, the remaining curve points are set in reverse order **P8** to **P1** and then **P0** is set to obtain a good start.

! When reviewing curvepoints after calculating them, check and adjust each curvepoint in order to achieve good combustion.

Move to curvepoint **P1**.

When **P1** flashes, press ESC $-$ $+$.

! If the burner goes into blocking mode when increasing to full load, restart the setting procedure and adjust the curvepoints in order to avoid the burner entering blocking mode.

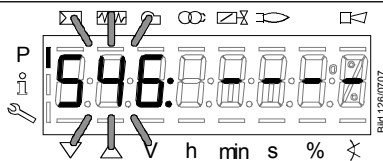

The maximum capacity is displayed.

If the display shows - - - , the maximum capacity has not yet been specified.

The system can be run up to 100% capacity.

You can press I/reset to go to editing mode, enabling you to change the maximum capacity.

Adjust the setting downwards or upwards using the buttons $-$ $+$.

Press I/reset to save the setting.



Press ESC $-$ $+$ to return to parameter level.

The benefit of setting the maximum input power in this way is that at a later date it is easy to change the input power without having to adjust the amount of air and gas. The setting curve is therefore adjusted to the highest input power that the installation can handle. The desired input power is then set by entering how much of the maximum power is required.

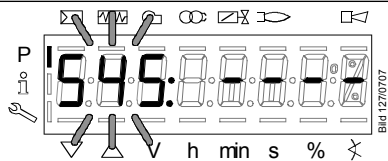

To the next parameter .



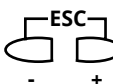

The minimum capacity is displayed.
 If the display shows - - - , the minimum capacity has not yet been entered.
 The system can be run down to 20% capacity.
 You can press  to go to editing mode, enabling you to change the minimum capacity.

Adjust the setting downwards or upwards using the buttons .
 Press  to save the setting.
 Press  to return to parameter level.

The benefit of setting the minimum input power in this way is that at a later date it is easy to change the input power without having to adjust the amount of air and gas. The setting curve is therefore adjusted to the lowest input power that the installation can handle. The desired input power is then set by entering how much of the minimum power is required.

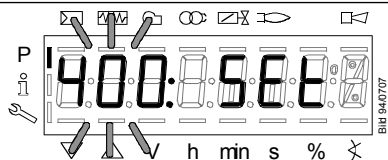
Completing parameterization of the curve . Back to the previous parameter .

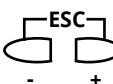

When symbol  or  is no longer highlighted, you can press **ESC** a second time.

Press  to exit parameter level.

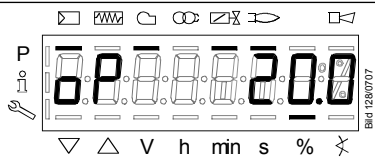

The settings for air-fuel ratio control by the LMV37.4... are now completed.

5.5.3 The parameters below may need to be set according to the nature of the installation

To change any of the parameters set out below, go into parameter level and make the required adjustments.

5.5.3.1 Pressure switch-min input

236 Gas: Pressure switch-min input

0 = inactive

1 = pressure switch-min (upstream of fuel valve 1)

2 = valve proving via pressure switch-min (between fuel valves 1 and 2)

Factory settings marked with bold text.

5.5.3.2 Execution valve proving

241 Gas: Execution valve proving

0 = no valve proving

1 = valve proving on startup

2 = valve proving on shutdown

3 = valve proving on startup and shutdown

Factory settings marked with bold text.

At an input power higher than 1,200 kW, a tightness test must be performed. At an input power lower than 1,200 kW, performing a tightness test is optional. It is essential for all changes to take local standards and regulations into consideration.

5.5.3.3 No-flame positions fuel actuator

501 No-flame positions fuel actuator

Index 0 = no-load position

Index 1 = pre purge position

Index 2 = post purge position

Factory settings marked with bold text.

5.5.3.4 No-flame positions air actuator

502 No-flame positions air actuator

Index 0 = no-load position

Index 1 = pre purge position

Index 2 = post purge position

Factory settings marked with bold text.

5.5.3.5 Active detector flame evaluation

221 Gas: Active detector flame evaluation

0 = QRB / QRC

1 = ION / QRA

Factory settings marked with bold text.

! This manual describes "1 = pressure switch-min (upstream of fuel valve 1)" type burners.

! The automatic control unit should be set to "Index 0 = no-load position".

! The automatic control unit should be set to "Index 0 = no-load position".

When replacing detector flame between ionisation and UV-cell (QRA), no change to the setting parameters is required; simply disconnect and connect ionisation and UV-cell (QRA) respectively..

5.5.3.6 Prepurging

222 Gas: Prepurging

Index 0 = deactivated

Index 1 = activated

Factory settings marked with bold text

When using valve proving and 2 fuel valves of class A, prepurging is not required (conforming to EN 676).

If not activated, it is nevertheless performed if one or several of the following conditions apply:

- Alterable lockout position
- After an off time of >24 hours
- In the event of a power failure (power-on)
- In the event of shutdown due to an interruption of gas supply (safety shutdown)

5.5.3.7 Prepurging time

225 Gas: Prepurging time

20 s – 60 min

5.5.3.8 Postpurge time

234 Gas: Postpurge time (no external light test)

0,2 s – 108 min

5.5.3.9 Postpurging in lockout position

190 Postpurging in lockout position

0 = deactivate (no-load position)

1 = active (postpurge position)

Factory settings marked with bold text.

When active, the Alarm in the event of start prevention function (parameter 210) is only possible to a limited extent!

The LMV37.4 system simply moves the actuators to the postpurge position. A fan release contact cannot be controlled, as the alarm relay of the LMV37.4 system cuts off the power supply to the outputs. With the Alarm in the event of start prevention function, an external circuit that may be present for controlling the fan release contact for purging in the lockout position is activated via start prevention in standby mode.



When the Purging in the lockout position function is used, the fan may only be powered via a contactor and must not be connected directly to LMV37.4 (X3-05 pin 1)!

5.5.3.10 Continuous fan

A burner can be converted into a continuous fan using a conversion kit, see the documentation provided with the kit for instructions on conversion.

5.5.3.11 Continuous operation

The LMV37 automatic control unit permits continuous operation of the burner, provided that the burner's detector flame is an ionisation detector flame.

When forced intermittent operation is activated, the unit shuts down for a moment after 23 hours and 45 min of uninterrupted operation, followed by an automatic restart.

When forced intermittent operation is inactivated the burner will run continuously.

Forced intermittent operation is a standard feature.

239 Gas: Forced intermittent operation

0 = inactivate

1 = activated

Factory settings marked with bold text.

5.6 Backup and restore



When adjustments to the burner are complete, it is a good idea to make a backup of the settings.

The backup ensures that the adjusted values are also saved in the display memory. This can be useful, e.g. if there are any problems with the LMV. The LMV can then be replaced and previous settings for the burner restored from the display memory to the new LMV.

Backup: Means that the parameters set on the LMV control unit are saved in the display memory.

Restore: Means that the settings saved in the display memory are transferred to the LMV and these overwrite any settings already in the LMV. The transferred parameter settings then act as operating parameters for the burner.



5.6.1 Backup

Press   > 1 second to access login mode.

F **A**

To continue with the setting work, you need to log into service engineer level, see section "Access code for service engineer level".

After login is complete, continue with the setting work as shown below.

Press  or  for parameter level **000**.

Press 
 ↵/reset

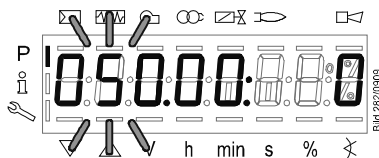

Display: Parameter **050**, flashes, index **00**, and value **0** do not.

 ↵/reset

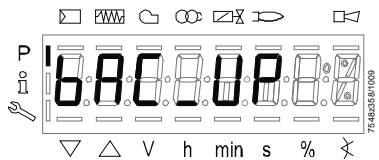



Display: Parameter **bAC_UP**

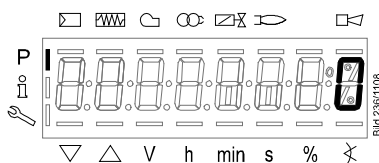

 ↵/reset



Display: Value **0**

Press  to backup process.

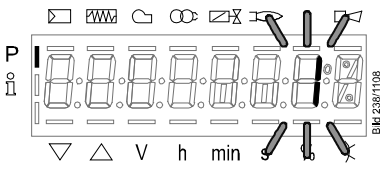
Press  to shift the value in change mode 1 position to the left.



Display: Value 1 flashes

! To detect potential display errors, the value is displayed 1 place shifted to the left

! Note! The value must be set to 1 if a backup is required, and to 0 if a backup is not required. The values higher than 1 which can be set must not be used.

Press  to activate the backup process.

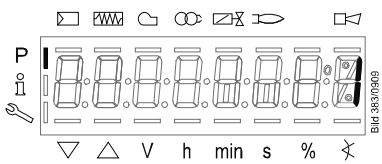

Display: 1 appears

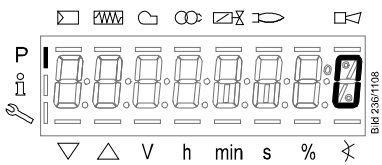



After about 5 seconds (depending on the duration of the program), 0 appears on the display, indicating the end of the backup process.

Display: 0

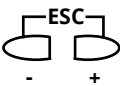
! If an error occurs during the backup process, a negativ value is displayed. For error diagnostics, the cause of the error can be determined from the diagnostic code of error message 137 (see Error code list)



Press  four times until the top menu is displayed.



5.6.2 Restore

Press    > 1 second to access login mode.

To continue with the setting work, you need to log into service engineer level, see section "Access code for service engineer level".



After login is complete, continue with the setting work as shown below.

Press  or  for parameter level **000**.

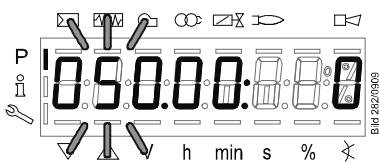
Press 
 /reset



Display: Parameter **050**, flashes, index **00**, and value **0** do not.

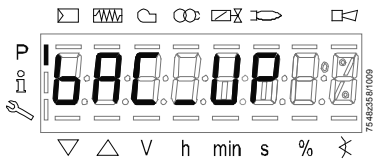

 /reset



Display: Parameter **bAC_UP**

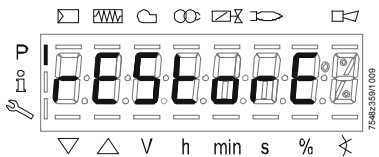

Press  to select parameter **rESstorE**



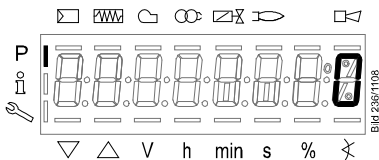

 /reset



Display: Value **0**

Press 
 /reset to select the restore process.

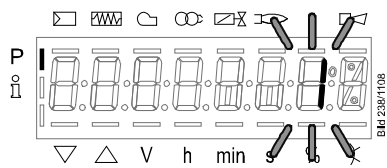
Press  to shift the value in change mode 1 position to the left.



Display: Value 1 flashes

! To detect potential display errors, the value is displayed 1 place shifted to the left

Press  to activate the the restore process.
 /reset

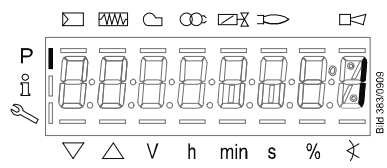

Display: 1 appears

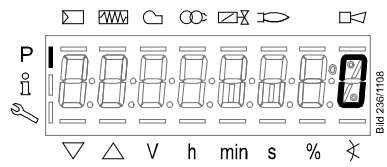

After about 8 seconds (depending on the duration of the program), 0 appears on the display, indicating the end of the backup process.

Display: 0

Press  four times until the top menu is displayed.

5.7 Fault status message, display of errors and info

5.7.1 Display of errors (faults) with lockout

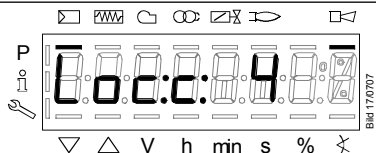

The display shows Loc., the bar under the fault status message  appears.

The unit is in the lockout position.

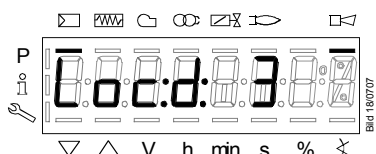

The display shows current error code c: alternating with diagnostic code d: (refer to Flash code list).

Example: Error code 4/diagnostic code 3

When pressing  for 1...3 s, **rESEt** appears on the display.



When the button is released, the basic unit is reset.

If the  button is pressed for a time other than the time indicated above, a change to the previous menu is made.

Exception
If an error occurred while setting the curve, a change back to the parameter setting level is made.

5.7.2 Activating info / service mode from lockout

 >3 s

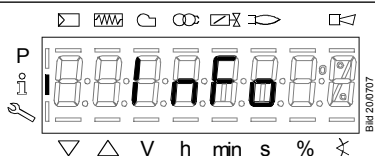

When pressing  for >3 s, the display shows InFo,

 >5 s

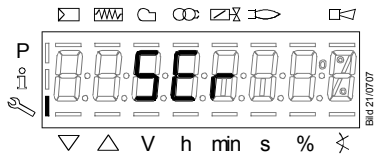

SEr and then **OPeRAte**.

For a list of parameters, see table "Parameter of level service".

 >8 s

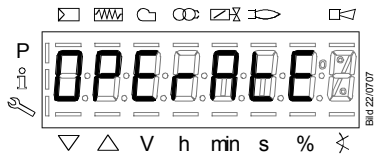

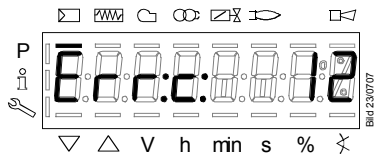

When the button is released, a change to info / service mode is made.

5.7.3 Error with safety shutdown

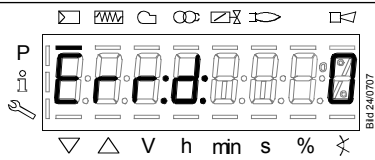

The display shows **Err:**.
 The unit initiates safety shutdown.
 The display shows current error code c:
 alternating with diagnostic code d:.



Press  1...3 s, to return to the normal display.
 ↻/reset

Example: Error code **12** / diagnostic code **0**

5.7.4 Error history

Press > 1 second to access login mode.

To continue with the setting work, you need to log into service engineer level, see section "Access code for service engineer level".

After login is complete, continue with the setting work as shown below.

Press or for parameter level **700**.

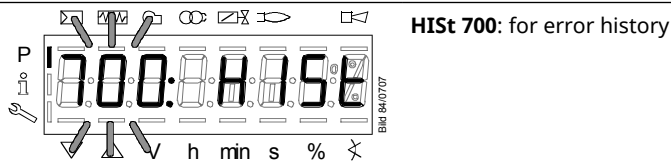

Press to go to the parameter level.

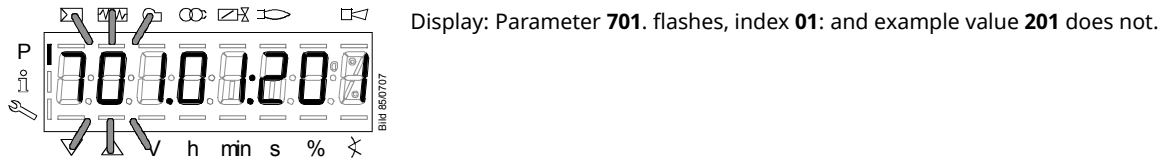

Press to go to index 01:

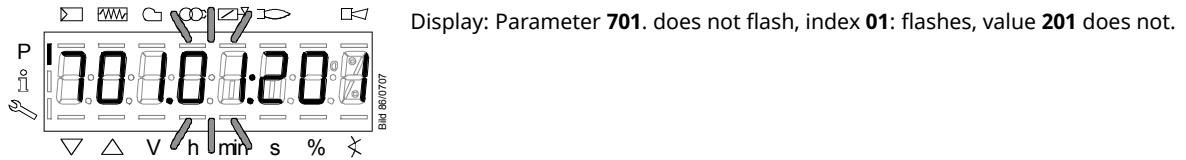

To the next index . Back to the previous index .

Press to select the index:





- .01 = error code
- .02 = diagnostic code
- .03 = error class
- .04 = error phase
- .05 = startup counter
- .06 = output

Example:

Parameter **701.**, index **05**: for startup counter, diagnostic code **._.**

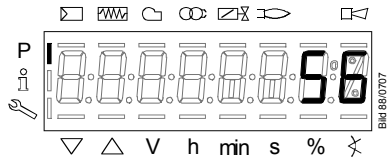
/reset



Press  to go to display mode.
/reset

Display: Value **56** (number of startup)

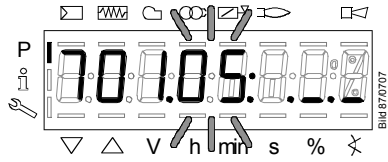
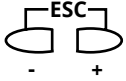

Press  to return to the index.

Display: Parameter **701**. does not flash, index **05**: flashes, characters **._.** do not.

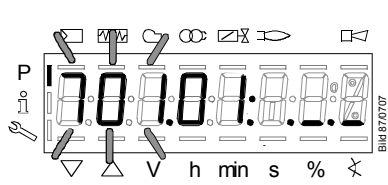
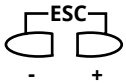

Press  to return to the parameter level.

Display: Parameter **701**. flashes index **01**: does not, characters **._.** do not.

To the next old error .

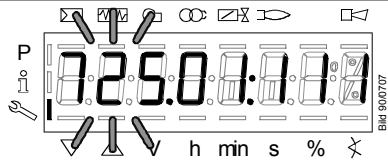

Shows all saved error codes between 701 and 725.



Parameters cover the period of time back to the last error since history was deleted (max. to parameter **725**.)

Example:

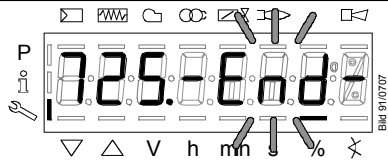

Parameter **725**., index **01**.; error code **111**

To the next parameter . Back to the previous parameter .



When this display appears, you have reached the end of the error history index.

Display - **End** - appears flashing.

To the next index . Back to the previous index .

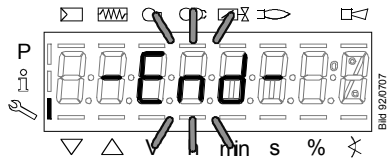

When this display appears, you have reached the end of the error history.

Display - **End** - appears flashing.

Press  twice.

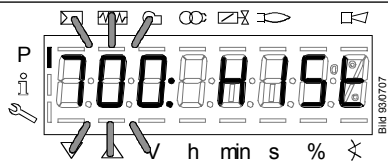

HIST 700: for error history

5.8 Display message of info

5.8.1 General information

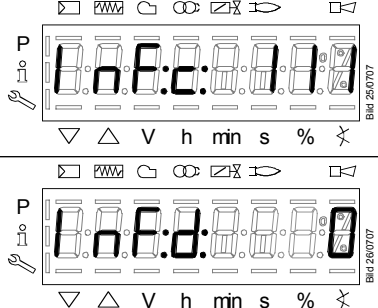

The unit displays an event which does not lead to shutdown.

The display shows current error code c: alternating with diagnostic code d:.

Press  to return to the display of phases.

t/reset

Example: Error code **111** / diagnostic code **0**

Note
 For meaning of the error and diagnostic codes, refer to chapter Error code list. When an error has been acknowledged, it can still be read out from the error history.

5.8.2 Start prevention

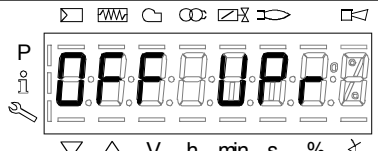

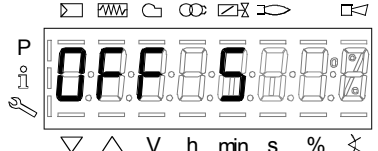

A non-programmed or not completely parameterized unit, or a unit whose operating mode was reset or changed, displays **OFF UPPr**.

5.8.3 Safety loop







A unit whose safety loop and / or burner flange contact is open, and a controller ON signal is present, displays **OFF S**.

5.9 Resetting the automatic control unit

Press   > 1 second to access login mode.



To continue with the setting work, you need to log into service engineer level, see section "Access code for service engineer level".

After login is complete, move to parameter level **200** using  or .

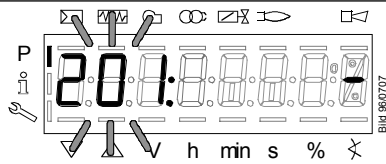

Press 
/reset

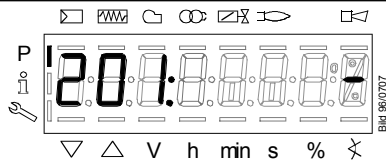

201: appears flashing

Press 
/reset to go to the settings for air-fuel ratio control and parameter **201** for selecting the operating mode.



Select another burner type than the one already selected by pressing one of the buttons  or .

Confirm this selection with 
/reset The automatic control unit is now reset.

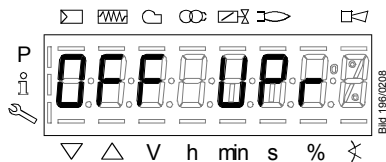

6. Parameter list

Par. no.	Parameter	Number of elements	Type	Edit	Value range		Resolution	Default setting	Password level
					Min	Max			
000	Internal parameters								
050	Start backup / restore via AZL2.../ PC software (set parameter to 1) Index 0: Create backup Index 1: Execute restore Error diagnostics via negative values (see error code 137)	2	Std_s8	edit	-99	50	1	0; 0	SO
055	Burner identification of AZL2... backup data set	1	Std_s32	read only	0	99999999	1	0	SO
056	ASN extraction of AZL2... backup data set	8	Std_u8	read only	0	127	1	0	SO
057	Software version when creating the AZL2... backup data set	1	Hex_16	read only	0x100	0xFF9	1	0	SO
100	General								
102	Identification date	1	Date	read only	0	255	1		Info / Service
103	Identification number	1	Std_u16	read only	0	65535	1		Info / Service
104	Preselected parameter set: Customer code	1	Std_u8	read only	0	255	1	9	Info / Service
105	Preselected parameter set: Version	1	Hex_16	read only	0	0xFFFF	1	LMV37.400...: V 01.05 LMV37.420...: V 01.06	Info / Service
107	Software version	1	Hex_16	read only	0x100	0xFF9	1	V 03.30	Info / Service
108	Software variant	1	Std_u8	read only	0	255	1	LMV37.400...: 1 LMV37.420...: 2	Info / Service
111	ASN extraction for verification with the AZL2... backup data set	8	Std_u8	read only	0	127	1	0	SO
113	Burner identification	1	Std_s32	edit	0	99999999	1	undefined	SO
121	Manual output Undefined = automatic mode	1	Output	edit / clear	0%	100%	0.1%	undefined	Info / Service
123	Minimum output positioning step Index 0: BACS output Index 1: Output of external load controller, analog Index 2: Output of external load controller contacts	3	Output	edit	0%	100%	0.1%	Index Value 0 0% 1 1% 2 0%	SO
124	Start loss-of-flame test (TUV test) (set parameter to 1) (shutdown of fuel valves → loss of flame)	1	Std_s8	edit	-6	1	1	0	SO
125	Error diagnostics via negative values (see error code 150) Mains frequency 0 = 50 Hz 1 = 60 Hz	1	Selection	edit	0	1	1	LMV37.400...: 0 LMV37.420...: 1	SO
126	Display brightness	1	Std_u8	edit	0%	100%	1%	LMV37.400...: 75 % LMV37.420...: 100 %	SO

Par. no.	Parameter	Number of elements	Type	Edit	Value range		Resolution	Default setting	Password level
					Min	Max			
128	Fuel meter: Pulse valency [pulses / volume unit]	1	Std_u16	edit	0	400	0.01	0	SO
130	Delete display of error history To delete the display: Set parameter to 1, then to 2 Return value 0: Job successfully completed Return value -1: Timeout of 1_2 sequence	1	Std_s8	edit	-5	2	1	0	SO
133	Default output for TÜV test Invalid = TÜV test when output is active 2.000...10.000 = low curve point (P1)...high-fire or stage 1 / stage 2 / stage 3	1	Output	edit / clear	20 %	100 %	0.1 %	undefined	SO
141	Operating mode BACS 0 = off 1 = Modbus 2 = reserved	1	Selection	edit	0	2	1	0	SO
142	Setback time in the event of communication breakdown Setting values 0 = inactive 1....7200 s	1	Std_u16	edit	0 s	7200 s	1 s	120 s	SO (BA)
143	Reserved	1	Std_u8	edit	1	8	1	1	Info / Service
144	Reserved	1	Std_u16	edit	10 s	60 s	1 s	30 s	SO
145	Device address for Modbus of basic unit Setting values 1...247	1	Std_u8	edit	1	247	1	1	SO
146	Setting of Baud rate for Modbus communication Setting values 0 = 9600 1 = 19200	1	Selection	edit	0	1	1	1	SO
147	Parity for Modbus 0 = none 1 = odd 2 = even	1	Selection	edit	0	2	1	0	SO
148	Default output if communication with building automation is interrupted Setting values: For modulation operation the setting range is as follows: 0...19.9 = burner off 20...100 = 20...100% burner rating For multistage operation apply to setting range: 0 = burner OFF, P1, P2, P3 Invalid = no default output predefined by building automation Default setting: Invalid	1	Output	edit / clear	0%	100%	0.1%	undefined	SO (BA)

Par. no.	Parameter	Number of elements	Type	Edit	Value range		Resolution	Default setting	Password level
					Min	Max			
161	Number of faults	1	Std_u16	read only	0	65535	1	0	Info / Service
162	Operating hours resettable	1	Std_s32	reset	0 h	9999999 h	1 h	0 h	Info / Service
163	Operating hours when unit is live	1	Std_s32	read only	0 h	9999999 h	1 h	0 h	Info / Service
164	Number of startups resettable	1	Std_s32	reset	0	9999999	1	0	Info / Service
166	Total number of startups	1	Std_s32	read only	0	9999999	1	0	Info / Service
167	Fuel volume resettable [m ³ , l, ft ³ , gal]	1	Std_s32	reset	0	999999999	1	0	Info / Service
176	Switching back to pilot switching cycles	1	Std_s32	read only	0	9999999	1	0	Info / Service
190	Postpurging in lockout position 0 = deactivate (no-load position) 1 = active (postpurge position) When active, the Alarm in the event of start prevention function is only possible to a limited extent!	1	Selection	edit	0	1	1	0	SO
191	Function Switching back to pilot 0 = deactivate 1 = active (low active) 2 = active (high active) Load controller contacts X5-03 are deactivated when function is active!	1	Std_u8	edit	0	2	1	0	SO
192	Switching back to pilot minimum time	1	Time	edit	5 s	120 s	0,2 s	30 s	SO
193	Switching back to pilot maximum time	1	Time	edit	30 s	108 min.	0,2 s	60 min.	SO
195	Repetition limit heavy oil direct start 1 = no repetition 2...15 = 1...14 number of repetitions 16 = constant repetition	1	Std_u8	edit	1	16	1	3	SO
196	Restart limit value: Air pressure failure 1 = no restart 2 = 1 restart 3 = 2 restarts Recharging time: At end of shutdown / 24 hours of continuous operation	1	Std_u8	edit	1	16		1	SO

Par. no.	Parameter	Number of elements	Type	Edit	Value range		Resolution	Default setting	Password level
					Min	Max			
200	Basic unit								
201	Burner operating mode (fuel train, modulating / multistage, actuators, etc.) -- = undefined (delete curves) 1 = G mod 2 = Gp1 mod 3 = Gp2 mod 4 = Lo mod 5 = Lo 2-stage 6 = Lo 3-stage 7 = G mod pneu 8 = Gp1 mod pneu 9 = Gp2 mod pneu 10 = LoGp mod 11 = LoGp 2-stage 12 = Lo mod 2 fuel valves 13 = LoGp mod 2 fuel valves 14 = G mod pneu without actuator 15 = Gp1 mod pneu without actuator 16 = Gp2 mod pneu without actuator 17 = Lo 2-stage without actuator 18 = Lo 3-stage without actuator 19 = G mod only gas actuator 20 = Gp1 mod only gas actuator 21 = Gp2 mod only gas actuator 22 = Lo mod only oil actuator 23 = Ho mod. sep. circulation 24 = Ho 2-stage sep. circulation 25 = Ho mod. without circulation 26 = Ho 2-stage without circulation 27 = Ho 3-stage without circulation	1	Selection	edit / clear	1	27	1	undefined	SO
204	Analog output invalid (4...20 mA) 0 = default load low curve point 1 = safety shutdown + start prevention	1	Std_u8	edit	0	1	1	1	SO
208	Program stop 0 = inactive 1 = PrePurgP (Ph24) 2 = IgnitPos (Ph36) 3 = interval 1 (Ph44) 4 = interval 2 (Ph52)	1	Selection	edit	0	4	1	0	SO (BA)

Par. no.	Parameter	Number of elements	Type	Edit	Value range		Resolution	Default setting	Password level
					Min	Max			
210	Alarm in the event of start prevention 0 = deactivated 1 = activated	1	Selection	edit	0	1	1	LMV37,400...:0 LMV37,420...:1	SO
211	Fan ramp up time	1	Time	edit	2 s	60 s	0.2 s	2 s	SO
212	Max. time down to low curve point	1	Time	edit	0.2 s	10 min	0.2 s	45 s	SO
215	Repetition limit safety loop 1 = no repetition 2...15 = 1...14 number of repetitions 16 = constant repetition	1	Std_u8	edit	1	16	1	LMV37,400...:16 LMV37,420...:1	SO
221	Gas: Active detector flame evaluation 0 = QRB / QRC 1 = ION / QRA	1	Selection	edit	0	1	1	1	SO
222	Gas: Prepurging 0 = deactivated 1 = activated	1	Selection	edit	0	1	1	1	SO
223	Repetition limit gas pressure switch-min 1 = no repetition 2...15 = 1...14 number of repetitions 16 = constant repetition	1	Std_u8	edit	1	16	1	LMV37,400...:16 LMV37,420...:1	SO
225	Gas: Prepurge time	1	Time	edit	LMV37. 400...:20 s LMV37. 420...:5 s	60 min	0.2 s	LMV37. 400...:20 s LMV37. 420...:30 s	SO
226	Gas: Preignition time	1	Time	edit	0.4 s	60 min	0.2 s	2 s	SO
230	Gas: Interval 1	1	Time	edit	0.4 s	60 s	0.2 s	2 s	SO
232	Gas: Interval 2	1	Time	edit	0.4 s	60 s	0.2 s	2 s	SO
233	Gas: Afterburn time	1	Time	edit	0.2 s	60 s	0.2 s	8 s	SO
234	Gas: Postpurge time (no extraneous light test)	1	Time	edit	0.2 s	108 min	0.2 s	LMV37,400...:0.2 s LMV37,420...:15 s	SO
235	Gas: Air pressure switch (LP) 0 = inactive 1 = active 2 = active, except phase 60...66 (pneumatic operation only)	1	Selection	edit	1	2	1	1	SO
236	Gas: Pressure switch-min input 0 = inactive 1 = pressure switch-min (upstream of fuel valve 1 (V1)) 2 = valve proving via pressure switch-min (between fuel valves 1 (V1) and 2 (V2))	1	Selection	edit	1	2	1	1	SO

Par. no.	Parameter	Number of elements	Type	Edit	Value range		Resolution	Default setting	Password level
					Min	Max			
237	Gas: Pressure switch-max / POC input 0 = inactive 1 = pressure switch-max 2 = POC 3 = pressure switch valve proving	1	Selection	edit	1	2	1	LMV37,400....:1 LMV37,420....:2	SO
239	Gas: Forced intermittent operation 0 = inactive 1 = activated	1	Selection	edit	0	1	1	1	SO
241	Gas: Execution valve proving 0 = no valve proving 1 = valve proving on startup 2 = valve proving on shutdown 3 = valve proving on startup and shutdown	1	Selection	edit	0	3	1	LMV37,400....:2 LMV37,420....:0	SO
248	Gas: Postpurge time (t3) (abortion with load controller (LR)-ON)	1	Time	edit	1 s	108 min	0.2 s	1 s	SO
400	Ratio curves								
401	Ratio control curve fuel actuator (only curve settings)	13	Std_s16	edit	0°	90°	0.1°	0°; 0°; 15°; undefined	SO
402	Ratio control curve air actuator (only curve settings)	13	Std_s16	edit	0°	90°	0.1°	0°; 90°; 45°; undefined	SO
403	Ratio control curve VSD (only curve settings)	13	Std_s16	edit	15 %	100%	0.1%	0%; 100%; 50%; undefined	SO
500	Ratio control								
501	No-flame positions fuel actuator Index 0 = home position Index 1 = prepurge position Index 2 = postpurge position	3	Std_s16	edit	0°	90°	0.1°	Index 0 0° 1 0° 2 15°	Value 0° 90° 45° SO
502	No-flame positions air actuator Index 0 = home position Index 1 = prepurge position Index 2 = postpurge position	3	Std_s16	edit	0°	90°	0.1°	Index 0 0° 1 90° 2 45°	Value 0° 90° 45° SO
503	No-flame speeds VSD Index 0 = no-load speed Index 1 = prepurge speed Index 2 = postpurge speed	3	Std_s16	edit	0%	100%	0.1%	Index 0 0% 1 100% 2 50%	Value 0% 100% 50% SO
522	Ramp up	1	Std_u8	edit	5 s	40 s	1 s	10 s	SO
523	Ramp down	1	Std_u8	edit	5 s	40 s	1 s	10 s	SO

Par. no.	Parameter	Number of elements	Type	Edit	Value range		Resolution	Default setting	Password level
					Min	Max			
542	Activation of VSD / PWM fan 0 = inactive 1 = active	1	Selection	edit	0	1	1	0	SO
544	Ramp modulating	1	Std_u8	edit	32 s	80 s	1 s	32 s	SO
545	Lower output limit undefined = 20 %	1	Output	edit / clear	20%	100%	0.1%	undefined	SO (BA)
546	Upper output limit undefined = 100 %	1	Output	edit / clear	20%	100%	0.1%	undefined	SO (BA)
600	Actuators								
601	Selection of reference point Index 0 = fuel Index 1 = air 0 = close (<90°) 1 = open (>90°)	2	Selection	edit	0	1	1	Index Value 0 1	SO
602	Actuator's direction of rotation Index 0 = fuel Index 1 = air 0 = counterclockwise 1 = clockwise (exclusively for SQM3...)	2	Selection	edit	0	1	1	Index Value 0 1	SO
606	Tolerance limit of position monitoring [0.1°] Index 0 = fuel Index 1 = air Greatest position error where a fault is securely detected → error detection band: (parameter 606-0.6°) to parameter 606	2	Std_u8	edit	0.5°	4°	0.1°	Index Value 0 1 1.7° 1.7°	SO
611	Type of referencing Index 0 = fuel Index 1 = air 0 = standard 1 = stop within usable range 2 = internal stop (SQN1...) 3 = both	2	Std_u8	edit	0	3	1	Index Value 0 1	SO
613	Type of actuator Index 0 = fuel Index 1 = air 0 = 5 s / 90° (1 Nm, 1,2 Nm, 3 Nm) 1 = 10 s / 90° (6 Nm) 2 = 17 s / 90° (10 Nm)	2	Std_u8	edit	0	2	1	0;0	SO

Par. no.	Parameter	Number of elements	Type	Edit	Value range		Resolution	Default setting	Password level
					Min	Max			
641	Control of speed standardization of VSD	1	Std_s8	edit	-25	1	1	0	SO
	Error diagnostics of negative values (refer to error code 82) 0 = no speed standardization 1 = speed standardization active								
642	Standardized speed	2	Std_u16	read only	650	6500	0.1	undefined	SO
	Index 0 = speed 1 Index 1 = speed 2 (internal supervision)								
645	Configuration of analog output	1	Std_u8	edit	0	2	1	0	SO
	0 = DC 0...10 V 1 = DC 2...10 V 2 = DC 0/2...10 V								
652	VSD behavior when safety loop / burner flange is open	1	Std_u8	edit	0	1	1	1	HF
	0 = no VSD control when safety loop / burner flange is open 1 = VSD control independent of safety loop / burner flange								
653	VSD standstill supervision in standby mode	1	Std_u8	edit	0	1	1	1	HF
	0 = deactivate 1 = active								
700	Error history								
701	Error history: 701-725.01.Code	25	Std_u8	read only	0	255	1	0	Info / Service
	Error history: 701-725.02.Diagnostic code	25	Std_u8	read only	0	255	1	0	Info / Service
•	Error history: 701-725.03.Error class	25	Std_u8	read only	0	6	1	0	Info / Service
	Error history: 701-725.04.Phase	25	Std_u8	read only	0	255	1	0	Info / Service
•	Error history: 701-725.05.Startup counter	25	Std_s32	read only	0	99999999	1	0	Info / Service
	Error history: 701-725.06.Output	25	Output	read only	0%	100 %	0.1%	0%	Info / Service
900	Process data								
903	Current output	2	Output	read only	0%	100%	0.1%	0%	Info / Service
	Index 0 = fuel Index 1 = air								
922	Incremental position of actuators	2	Std_s16	read only	-50°	150°	0.01°	0°	Info / Service
	Index 0 = fuel Index 1 = air								
935	Absolute speed	1	Std_u16	read only	0	6553.5	0.1	0	SO
936	Standardized speed	1	Std_s16	read only	-200%	200%	0.1%	0%	Info / Service

Par. no.	Parameter	Number of elements	Type	Edit	Value range		Resolution	Default setting	Password level
					Min	Max			
942	Active load source 1 = output during curve settings 2 = manual output 3 = default: output via building automation 4 = default: output via analog input 5 = external load controller via contacts	1	Selection	read only	0	255	1	0	SO
947	Result of contact sensing (bit-coded) Bit 0.0 = 1: Pressure switch-min Bit 0.1 = 2: Pressure switch-max Bit 0.2 = 4: Pressure switch valve proving Bit 0.3 = 8: Pressure switch air pressure switch Bit 0.4 = 16: Load controller OPEN Bit 0.5 = 32: Load controller ON Bit 0.6 = 64: Load controller CLOSE Bit 0.7 = 128: Safety loop Bit 1.0 = 1: Safety valve Bit 1.1 = 2: Ignition Bit 1.2 = 4: Fuel valve 1 Bit 1.3 = 8: Fuel valve 2 Bit 1.4 = 16: Fuel valve 3 / pilot valve Bit 1.5 = 32: Reset	2	Std_u8	read only	0	255	1	0	Info / Service
948	Contact feedback network counter register	14	Std_u8	read only	0	255	1	0	SO
950	Required relay state (bit-coded) Bit 0 = 1: Alarm Bit 1 = 2: Safety valve Bit 2 = 4: Ignition Bit 3 = 8: Fuel valve 1 Bit 4 = 16: Fuel valve 2 Bit 5 = 32: Fuel valve 3 / pilot valve	1	Std_u8	read only	0	255	1	0	Info / Service
951	Mains voltage (normalized) AC 230 V: Voltage = value x 1.683 AC 120 V: Voltage = value x 0.843	1	Std_u8	read only	0 V	255 V	1 V	0 V	SO
954	Intensity of flame	1	Std_u8	read only	0%	100%	1%	0%	Info / Service
960	Actual flow rate (m³/h, l/h, ft³/h, gal/h)	1	Std_u16	read only	0	6553.5	0.1	0	Info / Service
961	Phase (state for external modules and display)	1	Std_u8	read only	0	255	1	0	Info / Service
981	Error memory: Code	1	Std_u8	read only	0	255	1	0	Info / Service
982	Error memory: Diagnostic code	1	Std_u8	read only	0	255	1	0	Info / Service
992	Error flags	10	Hex_32	reset	0	0xFFFFFFFF	1	0	SO

Std_u8 8 bit integer, **not** signed
Std_u16 16 bit integer, **not** signed
Std_u32 32 bit integer, **not** signed

Std_s8 8 bit integer, signed
Std_s16 16 Bit integer, signed
Std_s32 32 Bit integer, signed

 This data type is also used to mark an invalid or non-signed value by using the value of -1!

7. Error code list

Error code	Diagnostic code	Meaning for the LMV37.4... system	Remedy
no Comm			
2	#	No communication between LMV37.4... basic unit and AZL2...	Check wiring for line interruption/loose contact
	1	No flame at the end of the safety time (TSA)	
	2	No flame at the end of safety time 1 (TSA1)	
	4	No flame at the end of safety time 2 (TSA2)	
	4	No flame at the end of safety time 1 (TSA1) (software version ≤ V02.00)	
3	#	Air pressure failure	
	0	Air pressure off	
	1	Air pressure on	
	2	Evaluation of air pressure	Correct the setting of parameter 235 or 335 (Deactivation of the air pressure check in operation only allowed in pneumatic operation!)
	4	Air pressure on - start prevention	
	20	Air pressure, combustion pressure - start prevention	
	68	Air pressure, POC - start prevention	
	84	Air pressure, combustion pressure, POC - start prevention	
4	#	Extraneous light	
	0	Extraneous light during startup	
	1	Extraneous light during shutdown	
	2	Extraneous light during startup - start prevention	
	6	Extraneous light during startup, air pressure - start prevention	
	18	Extraneous light during startup, combustion pressure - start prevention	
	24	Extraneous light during startup, air pressure, combustion pressure - start prevention	
	66	Extraneous light during startup, POC - start prevention	
	70	Extraneous light during startup, air pressure, POC - start prevention	
	82	Extraneous light during startup, combustion pressure, POC - start prevention	
	86	Extraneous light during startup, air pressure, combustion pressure, POC - start prevention	
7	#	Loss of flame	
	0	Loss of flame	
	3	Loss of flame (software version ≤ V02.00)	
	3...255	Loss of flame due to TÜV test (loss-of-flame test)	

Error code	Diagnostic code	Meaning for the LMV37.4... system	Remedy
12	#	Valve proving	
	0	Fuel valve 1 (V1) leaking (fuel valve 2 with valve proving via X5-01)	For valve proving via X5-01 (gas pressure switch-min) - Check to see if the valve on the burner side is leaking - Check to see if the pressure switch for the valve proving is closed when gas pressure is present - Check wiring to see if there is a short-circuit
	1	Fuel valve 2 (V2) leaking (fuel valve 1 with valve proving via X5-01)	For valve proving via X5-01 (gas pressure switch-min) - Check to see if the valve on the gas side is leaking - Check wiring to see if there is a short-circuit
	2	Valve proving not possible	Valve proving activated, but pressure switch-min selected as input function for X9-04 (check parameters 238 and 241)
	3	Valve proving not possible	Valve proving activated, but no input assigned (check parameters 236 and 237)
	4	Valve proving not possible	Valve proving activated, but 2 inputs assigned (set parameter 237 to pressure switch-max or POC)
	5	Valve proving not possible	Valve proving activated, but 2 inputs assigned (check parameters 236 and 237)
	81	V1 leaking	Check to see if the valve on the gas side is leaking Check wiring to see if there is an open-circuit
	83	V2 leaking	Check to see if the valve on the burner side is leaking Check to see if the pressure switch for the leakage test is closed when gas pressure is present Check wiring for short-circuit
14	#	POC	
	0	POC open	Check to see if the valve's closing contact is closed
	1	POC close	Check wiring
	64	POC open - prevention of startup	Check to see if the valve's closing contact opens when valve is controlled Check wiring to see if there is a line interruption. Check to see if the valve's closing contact is closed
19	80	Combustion pressure, POC - start prevention	Check to see if pressure switch has closed with no combustion pressure present Check wiring for short-circuit
20	#	Pressure switch-min (Pmin)	
	0	No minimum gas /oil pressure	Check wiring for line interruption
	1	Gas shortage - start prevention	Check wiring for line interruption
21	#	Pressure switch-max (Pmax) / POC	
	0	Pressure switch-max (Pmax): Max. gas / oil pressure exceeded POC: POC open (software version ≤ V02.00)	Check wiring to see if there is a line interruption. POC: Check to see if the valve's closing contact is closed.
	1	POC close (software version ≤ V02.00)	Check wiring. Check to see if the valve's closing contact opens when the valve is controlled

Error code	Diagnostic code	Meaning for the LMV37.4... system	Remedy
	64	POC open – start prevention (software version ≤ V02.00)	Check wiring. Check whether valve's make contact opens when valve is controlled
22 OFF S	#	Safety loop / burner flange	
	0	Safety loop / burner flange open	
	1	Safety loop / burner flange open – start prevention	
	3	Safety loop/burner flange, extraneous light – start prevention	
	5	Safety loop/burner flange, air pressure – start prevention	
	17	Safety loop/burner flange, combustion pressure – start prevention	
	19	Safety loop/burner flange, extraneous light, combustion pressure – start prevention	
	21	Safety loop/burner flange, air pressure, combustion pressure – start prevention	
	23	Safety loop/burner flange, extraneous light, air pressure, combustion pressure – start prevention	
	65	Safety loop/burner flange, POC – start prevention	
	67	Safety loop/burner flange, extraneous light, POC – start prevention	
	69	Safety loop/burner flange, air pressure, POC – start prevention	
	71	Safety loop/burner flange, extraneous light, air pressure, POC – start prevention	
	81	Safety loop/burner flange, combustion pressure, POC – start prevention	
	83	Safety loop/burner flange, extraneous light, combustion pressure, POC – start prevention	
	85	Safety loop/burner flange, air pressure, combustion pressure, POC – start prevention	
	87	Safety loop/burner flange, extraneous light, air pressure, combustion pressure, POC – start prevention	
23	#	Gas pressure switch-min (Pmin) / heavy oil direct start	
	0	No minimum gas pressure	Check wiring to see if there is an open-circuit (X5-01)
	1	Gas shortage – start prevention	Check wiring to see if there is an open-circuit (X5-01)
	2	Heavy oil direct start	Check wiring to see if there is an open-circuit (X9-04) Check that the oil is preheated correctly
51	#	Internal error	Make a reset; if error occurs repeatedly, replace the unit
55	#	Internal error	Make a reset; if error occurs repeatedly, replace the unit
56	#	Internal error	Make a reset; if error occurs repeatedly, replace the unit
57	#	Internal error	Make a reset; if error occurs repeatedly, replace the unit

Error code	Diagnostic code	Meaning for the LMV37.4... system	Remedy
58	#	Internal error	Make a reset; if error occurs repeatedly, replace the unit
60	0	Internal error: No valid output source	Make a reset; if error occurs repeatedly, replace the unit
65	#	Internal error	Make a reset; if error occurs repeatedly, replace the unit
66	#	Internal error	Make a reset; if error occurs repeatedly, replace the unit
67	#	Internal error	Make a reset; if error occurs repeatedly, replace the unit
70	#	Error air-fuel ratio control: Position calculation modulating	
	23	Output invalid	No valid output
	26	Curvepoints undefined	Adjust the curvepoints for all actuators
71	#	Special position undefined	
	0	Home position	Parameterize the home position for all actuators used
	1	Prepurge position	Parameterize the prepurge position for all actuators used
	2	Postpurge position	Parameterize the postpurge position for all actuators used
	3	Ignition position	Parameterize the ignition position for all actuators used
72	#	Internal error air-fuel ratio control	Make a reset; if error occurs repeatedly, replace the unit
73	#	Internal error air-fuel control: Position calculation multistep	
	23	Output invalid	No valid output
	26	Curvepoints undefined	Adjust the curvepoints for all actuators
75	#	Internal error air-fuel ratio control: Data clocking check	
	1	Current output different	
	2	Target output different	
	4	Target positions different	
	16	Different positions reached	Can be caused by different standardized speeds (e.g. after restore of data set) when the VSD is activated → standardize again and check adjustment of the air-fuel ratio control system
76	#	Internal error air-fuel ratio control	Make a reset; if error occurs repeatedly, replace the unit
80	#	Control range limitation of VSD	Basic unit could not correct the difference in speed and reached a control range limit. 1. Basic unit is not standardized for this motor → repeat standardization.
 Caution! Settings of air-fuel ratio control must be checked!			
2. Ramp time settings of the VSD are not shorter than those of the basic unit (parameters 522, 523) or the setting for the modulating operating ramp is incorrect (parameter 544)			
3. Characteristic of the VSD is not linear. Configuration of the voltage input at the VSD must accord with that of the basic unit (parameter 645).			
4. VSD does not follow quickly enough the changes of the basic unit. Check settings of the VSD (input filter, slippage compensation, hiding different speeds			

Error code	Diagnostic code	Meaning for the LMV37.4... system	Remedy
	1	Control range limitation at the bottom	VSD speed was too high
	2	Control range limitation at the top	VSD speed was too low
81	1	Interrupt limitation speed input	Too much electromagnetic interference on the sensor line → improve EMC
82	#	Error during VSD's speed standardization	
	1	Timeout of standardization (VSD ramp down time too long)	Timeout at the end of standardization during ramp down of the VSD → ramp time settings of the VSD are not shorter than those of the basic unit (parameter: 523)
	2	Storage of standardized speed not successful	Error during storage of the standardized speed → lock the basic unit, then reset it and repeat the standardization
	3	Line interruption speed sensor	Basic unit receives no pulses from the speed sensor: 1. Motor does not turn. 2. Speed sensor is not connected. 3. Speed sensor is not activated by the sensor disk (check distance)
	4	Speed variation / VSD ramp up time too long / speed below minimum limit for standardization	Motor has not reached a stable speed after ramp up. 1. Ramp time settings of the VSD are not shorter than those of the basic unit (parameters 522, 523). 2. Characteristic of the VSD is not linear. Configuration of the voltage input at the VSD must accord with that of the basic unit (parameter 645). 3. VSD does not follow quickly enough the changes of the basic unit. Check settings of the VSD (input filter, slippage compensation, hiding different speeds) 4. Speed of VSD lies below the minimum for standardization (650 1/min)
	5	Wrong direction of rotation	Motor's direction of rotation is wrong. 1. Motor turns indeed in the wrong direction → change parameterization of the direction of rotation or interchange 2 live conductors. 2. Sensor disk is fitted the wrong way → turn the sensor disk.
	6	Unplausible speed sensor signals	The required pulse pattern (60°, 120°, 180°) has not been correctly identified. 1. Speed sensor does not detect all tappets of the sensor disk → check distance 2. As the motor turns, other metal parts are detected also, in addition to the tappets → improve mounting. 3. Electromagnetic interference on the sensor lines → check cable routing, improve EMC

Error code	Diagnostic code	Meaning for the LMV37.4... system	Remedy
7	Invalid standardized speed		The standardized speed measured does not lie in the permissible range → motor turns too slowly or too fast
15	Speed deviation $\mu C1 + \mu C2$		The speeds of microcomputer 1 and 2 deviated too much. This can be caused by wrong standardized speeds (e.g. after restoring a data set to a new unit) → repeat standardization and check the air-fuel ratio
20	Wrong phase of phase manager		Standardization was made in a wrong phase. Permitted are only phases ≤ 12 → controller OFF, start standardization again
21	Safety loop / burner flange open		Safety loop or burner flange is open → repeat standardization with safety loop closed
22	Air actuator not referenced		Air actuator has not been referenced or has lost its referencing. 1. Check if the reference position can be approached. 2. Check if actuators have been mixed up. 3. If error only occurs after the start of standardization, the actuator might be overloaded and cannot reach its destination.
23	VSD deactivated		Standardization was started with VSD deactivated → activate the VSD and repeat standardization
24	No valid operating mode		Standardization was started without valid operating mode → activate valid operating mode and repeat standardization
25	Pneumatic air-fuel ratio control		Standardization was started with pneumatic air-fuel ratio control → standardization with pneumatic air-fuel ratio control not possible
128	Running command with no preceding standardization		VSD is controlled but not standardized → make standardization
255	No standardized speed available		Motor turns but is not standardized → make standardization
83	#	Speed error VSD	Required speed has not been reached
Bit 0	Valency 1	Lower control range limitation	Speed has not been reached because control range limitation has become active → for measures, refer to error code 80
Bit 1	Valency 2...3	Upper control range limitation	Speed has not been reached because control range limitation has become active → for measures, refer to error code 80
Bit 2	Valency 4...7	Interrupt shutdown due to electromagnetic interference	Speed has not been reached due to too much electromagnetic interference on the sensor line → for measures, refer to error code 81

Error code	Diagnostic code	Meaning for the LMV37.4... system	Remedy
	Bit 3 Valency ≥ 8	Curve too steep in terms of ramp speed	Check speed differential between the curvepoints and the modulating operating ramp setting (parameter 544). 1. Modulating operating ramp 32 seconds Curve slope max. 10% for LMV37.4 ramp of 20 seconds (20% for 10 seconds or 40% for 5 seconds) 2. Modulating operating ramp 48 seconds Curve slope max. 10% for LMV37.4 ramp of 30 seconds (20% for 15 seconds or 30% for 10 seconds) 3. Modulating operating ramp 64 seconds Curve slope max. 10% for LMV37.4 ramp of 40 seconds (20% for 20 seconds or 40% for 10 seconds) → Between the ignition point (P0) and the low curve point (P1), the speed change in modulating mode may be a maximum of 40%, independent of the LMV3... ramp. 2. The setting of the VSD ramp must be about 20% faster than the ramps in the basic unit (parameters 522, 523).
	Bit 4 Valency ≥ 16	Interruption of speed signal	No speed detected in spite of control. 1. Check if the motor turns. 2. Check if the speed sensor delivers a signal (LED / check distance from the sensor disk). 3. Check wiring of the VSD.
	Bit 5 Valency ≥ 32	Quick shutdown due to excessive speed deviation	Speed deviation was for about 1 s > 10% outside the anticipated range. 1. Check ramp times of the LMV37.4... and VSD. 2. Check wiring of the VSD.
84	Curve slope actuators Bit 0 Valency 1	VSD: Curve too steep in terms of ramp speed	Check speed differential between the curvepoints and the modulating operating ramp setting (parameter 544). 1. Modulating operating ramp 32 seconds Curve slope max. 10% for LMV37.4 ramp of 20 seconds (20% for 10 seconds or 40% for 5 seconds) 2. Modulating operating ramp 48 seconds Curve slope max. 10% for LMV37.4 ramp of 30 seconds (20% for 15 seconds or 30% for 10 seconds) 3. Modulating operating ramp 64 seconds Curve slope max. 10% for LMV37.4 ramp of 40 seconds (20% for 20 seconds or 40% for 10 seconds) → Between the ignition point (P0) and the low curve point (P1), the speed change in modulating mode may be a maximum of 40%, independent of the LMV3... ramp. 2. Setting of the VSD ramp must be about 20% shorter than the ramps in the basic unit (parameters 522 and 523)

Error code	Diagnostic code	Meaning for the LMV37.4... system	Remedy
	Bit 1 Valency 2..3	Fuel actuator: Curve too steep in terms of ramp rate	<p>Check position differential between the curvepoints and the modulating operating ramp setting (parameter 544).</p> <ol style="list-style-type: none"> Modulating operating ramp 32 seconds The slope of the curve may be a maximum position change of 31° (15° for SQM33.6 and 9° for SQM33.7) between 2 curve points in modulating mode. Modulating operating ramp 64 seconds The slope of the curve may be a maximum position change of 62° (30° for SQM33.6 and 18° for SQM33.7) between 2 curve points in modulating mode.
	Bit 2 Valency 4..7	Air actuator: Curve too steep in terms of ramp rate	<p>Check position differential between the curvepoints and the modulating operating ramp setting (parameter 544).</p> <ol style="list-style-type: none"> Modulating operating ramp 32 seconds The slope of the curve may be a maximum position change of 31° (15° for SQM33.6 and 9° for SQM33.7) between 2 curve points in modulating mode. Modulating operating ramp 64 seconds The slope of the curve may be a maximum position change of 62° (30° for SQM33.6 and 18° for SQM33.7) between 2 curve points in modulating mode.
85	#	Referencing error ones actuators	
	0	Referencing error of fuel actuator	<p>Referencing of fuel actuator not successful. Reference point could not be reached.</p> <ol style="list-style-type: none"> Check the setting of the actuator type (parameter 613.0 or 614) Check to see if actuators have been mixed up Check to see if actuator is locked or overloaded
	1	Referencing error of air actuator	<p>Referencing of fuel actuator not successful Reference point could not be reached.</p> <ol style="list-style-type: none"> Check the setting of the actuator type (parameter 613.1) Check to see if actuators have been mixed up Check to see if actuator is locked or overloaded
	Bit 7 Valency ≥ 128	Referencing error due to parameter change	<p>Parameterization of an actuator (e.g. the reference position) has been changed. To trigger new referencing, this error is set</p>
86	#	Error fuel actuator	
	0	Position error	<p>Target position could not be reached within the required tolerance band → check to see if actuator is locked or overloaded</p>
	Bit 0 Valency 1	Line interruption	<p>Line interruption detected at actuator's terminals → check wiring (voltage X54 across pin 5 or 6 and pin 2 >0.5 V)</p>

Error code	Diagnostic code	Meaning for the LMV37.4... system	Remedy
	Bit 3 Valency ≥ 8	Curve too steep in terms of ramp rate	<p>Check position differential between the curvepoints and the modulating operating ramp setting (parameter 544).</p> <ol style="list-style-type: none"> Modulating operating ramp 32 seconds The slope of the curve may be a maximum position change of 31° (15° for SQM33.6 and 9° for SQM33.7) between 2 curve points in modulating mode. Modulating operating ramp 64 seconds The slope of the curve may be a maximum position change of 62° (30° for SQM33.6 and 18° for SQM33.7) between 2 curve points in modulating mode. <p>Actuator was overloaded or mechanically twisted.</p> <ol style="list-style-type: none"> Check the setting of the actuator type (parameter 613.0 or 614) Check to see if the actuator is blocked somewhere along its working range. Check to see if the torque is sufficient for the application.
87	#	Error air actuator	Target position could not be reached within the required tolerance band → check to see if actuator is locked or overloaded
	0	Position error	
	Bit 0 Valency 1	Line interruption	Line interruption detected at actuator's terminals → check wiring (voltage X53 across pin 5 or 6 and pin 2 >0.5 V)
	Bit 3 Valency ≥ 8	Curve too steep in terms of ramp rate	<p>Check position differential between the curvepoints and the modulating operating ramp setting (parameter 544).</p> <ol style="list-style-type: none"> Modulating operating ramp 32 seconds The slope of the curve may be a maximum position change of 31° (15° for SQM33.6 and 9° for SQM33.7) between 2 curve points in modulating mode. Modulating operating ramp 64 seconds The slope of the curve may be a maximum position change of 62° (30° for SQM33.6 and 18° for SQM33.7) between 2 curve points in modulating mode. <p>Actuator was overloaded or mechanically twisted.</p> <ol style="list-style-type: none"> Check the setting of the actuator type (parameter 613.1) Check to see if the actuator is blocked somewhere along its working range. Check to see if the torque is sufficient for the application
90	#	Internal error basic unit	
91	#	Internal error basic unit	
93	#	Error flame signal acquisition	
	3	Short-circuit of sensor	<p>Short-circuit at QRB...</p> <ol style="list-style-type: none"> Check wiring. Flame detector possibly fault

Error code	Diagnostic code	Meaning for the LMV37.4... system	Remedy
95	# 3 Ignition transformer 4 Fuel valve 1 5 Fuel valve 2 6 Fuel valve 3	Error relay supervision External power supply active contact	Check wiring
96	# 3 Ignition transformer 4 Fuel valve 1 5 Fuel valve 2 6 Fuel valve 3	Error relay supervision Relay contacts have welded	Test the contacts: 1. Unit connected to power: Fan output must be dead. 2. Disconnect power: Disconnect fan. No resistive connection between fan output and neutral conductor allowed. If one of the 2 tests fails, release the unit since contact have definitively welded and safety can no longer be ensured.
97	# 0	Error relay supervision Safety relay contacts have welded or external power supply fed to safety relay	Test the contacts: 1. Unit connected to power: Fan output must be dead. 2. Disconnect power: Disconnect fan. No resistive connection between fan output and neutral conductor allowed. If one of the 2 tests fails, release the unit since contacts have definitively welded and safety can no longer be ensured.
98	# 2 Safety valve 3 Ignition transformer 4 Fuel valve 1 5 Fuel valve 2 6 Fuel valve 3	Error relay supervision Relay does not pull in	Make a reset; if error occurs repeatedly, replace the unit
99	# 3	Internal error relay control Internal error relay control	Make a reset; if error occurs repeatedly, replace the unit Make a reset. If error occurs repeatedly, replace the unit Software version V03.10: If error C:99 D:3 occurs during standardization of the VSD, deactivate temporarily function Alarm in case of start prevention (parameter 210 = 0, when using a release contact) or interrupt the controller-ON signal
100	#	Internal error relay control	Make a reset; if error occurs repeatedly, replace the unit
105	#	Internal error contact sampling	

Error code	Diagnostic code	Meaning for the LMV37.4... system	Remedy
	0 Pressure switch min 1 Pressure switch max / POC 2 Pressure switch valve proving 3 Air pressure 4 Load controller open 5 Load controller on / off 6 Load controller close 7 Safety loop / Burner flange 8 Safety valve 9 Ignition transformer 10 Fuel valve 1 11 Fuel valve 2 12 Fuel valve 3 13 Reset	Stuck-At failure	Can be caused by capacitive loads or supply of DC voltage to the mains voltage inputs. The diagnostic code indicates the input where the problem occurred
106	#	Internal error contact request	Make a reset; if error occurs repeatedly, replace the unit
107	#	Internal error contact request	Make a reset; if error occurs repeatedly, replace the unit
108	#	Internal error contact request	Make a reset; if error occurs repeatedly, replace the unit
110	#	Internal error voltage monitor test	Make a reset; if error occurs repeatedly, replace the unit
111	#	Mains undervoltage	Mains voltage to low Conversion factor diagnostic code → voltage value (AC 230 V: 1,683; AC 120 V: 0,843)
112	0	Mains voltage recovery	Error code for triggering a reset on power restoration (no error)
113	#	Internal error mains voltage supervision	Make a reset; if error occurs repeatedly, replace the unit
115	#	Internal error system counter	Warning threshold has been reached. The unit should be replaced
116	0	Designed lifecycle exceeded (250,000 startups)	Switch-off threshold has been reached
117	0	Life time exceeded Operation no longer allowed	
120	0	Interrupt limitation fuel counter input	Too many disturbance pulses at the fuel meters input → Improve EMC
121	#	Internal error EEPROM access	Make a reset, repeat last parameterization / check. Restore the parameter set, if error occurs repeatedly, replace the unit
122	#	Internal error EEPROM access	Make a reset, repeat last parameterization / check. Restore the parameter set, if error occurs repeatedly, replace the unit

Error code	Diagnostic code	Meaning for the LMV37.4... system	Remedy
123	#	Internal error EEPROM access	Make a reset, repeat last parameterization / check. Restore the parameter set, if error occurs repeatedly, replace the unit
124	#	Internal error EEPROM access	Make a reset, repeat last parameterization / check. Restore the parameter set, if error occurs repeatedly, replace the unit
125	#	Internal error EEPROM read access	Make a reset, repeat last parameterization / check. If error occurs repeatedly, replace the unit
126	#	Internal error EEPROM write access	Make a reset, repeat last parameterization / check. If error occurs repeatedly, replace the unit
127	#	Internal error EEPROM access	Make a reset, repeat last parameterization / check. Restore the parameter set, if error occurs repeatedly, replace the unit
128	0	Internal error EEPROM access - synchronization during initialization	Make a reset; if error occurs repeatedly, replace the unit
129	#	Internal error EEPROM access - command synchronization	Make a reset, repeat last parameterization / check. If error occurs repeatedly, replace the unit
130	#	Internal error EEPROM access - timeout	Make a reset, repeat last parameterization / check. If error occurs repeatedly, replace the unit
131	#	Internal error EEPROM access - page on abort	Make a reset, repeat last parameterization / check. If error occurs repeatedly, replace the unit
132	#	Internal error EEPROM register initialization	Make a reset; if error occurs repeatedly, replace the unit
133	#	Internal error EEPROM access - Request synchronization	Make a reset, repeat last parameterization / check. If error occurs repeatedly, replace the unit
134	#	Internal error EEPROM access - Request synchronization	Make a reset, repeat last parameterization / check. If error occurs repeatedly, replace the unit
135	#	Internal error EEPROM access - Request synchronization	Make a reset, repeat last parameterization / check. If error occurs repeatedly, replace the unit
136	#	Restore	
	1	Restore started	Restore of a backup has been started (no error)
			New devices require resetting following restore!
137	#	for further diagnostic codes for error code 136, refer to error code 137	For measures, refer to error code 137
	157 (-99)	Internal error - backup / restore Restore - ok, but backup < data set of current system	Restore successful, but backup data set is smaller than in the current system
	239 (-17)	Backup - storage of backup in AZL2... faulty	Make reset and repeat backup
	240 (-16)	Restore - no backup in AZL2...	No backup in AZL2...
	241 (-15)	Restore - interruption concerning unpassable ASN	The Backup has a unpassable ASN and may not restore of the unit
	242 (-14)	Backup - backup made is inconsistent	Backup is faulty and cannot be transferred back
	243 (-13)	Backup - data comparison between µCs faulty	Repeat reset and backup
	244 (-12)	Backup data are incompatible	Backup data are incompatible with the current software version, restore not possible
	245 (-11)	Access error to parameter Restore_Complete	Repeat reset and backup
	246 (-10)	Restore - timeout when storing in EEPROM	Repeat reset and backup
	247 (-9)	Data received are inconsistent	Backup data set invalid, restore not possible
	248 (-8)	Restore cannot at present be made	Repeat reset and backup
	249 (-7)	Restore - abortion due to unsuitable burner identification	Backup has an unsuitable burner identification and must not be transferred to the unit
	250 (-6)	Backup - CRC of one page is not correct	Backup data set invalid, restore not possible
	251 (-5)	Backup - burner identification is not defined	Define burner identification and repeat backup

Error code	Diagnostic code	Meaning for the LMV37.4... system	Remedy
	252 (-4)	After restore, pages still on ABORT	Repeat reset and backup
	253 (-3)	Restore cannot at present be made	Repeat reset and backup
	254 (-2)	Abortion due to transmission error	Repeat reset and backup
	255 (-1)	Abortion due to timeout during restore	Make a reset, check the connections and repeat the backup
146	#	Timeout building automation interface	Refer to User Documentation Modbus (A7541)
	1	Modbus timeout	
150	#	TÜV test	
	1 (-1)	Invalid phase	TÜV test may only be started in phase 60 (operation)
	2 (-2)	TÜV test default output too low	TÜV test default output must be lower than the lower output limit
	3 (-3)	TÜV test default output too high	TÜV test default output must be higher than the upper output limit
	4 (-4)	Manual abortion	No error: Manual abortion of TÜV test by the user
	5 (-5)	TÜV test timeout	No loss of flame after fuel valves have been shut 1. Check for extraneous light 2. Check wiring for short-circuit 3. Check to see if one of the valves is leaking
165	#	Internal error	
166	0	Internal error watchdog reset	
167	#	Manual locking	Unit has been manually locked (no error)
	1	Manual locking by contact	
	2	Manual locking by AZL2...	
	3	Manual locking by PC software	
	8	Manual locking by the AZL2... Timeout / communication breakdown	During a curve adjustment via the AZL2..., the timeout for menu operation has elapsed (setting via parameter 127), or communication between the LMV37.4... and the AZL2... has broken down
	9	Manual locking by the PC software Communication breakdown	During a curve adjustment via the ACS410, communication between the LMV37.4... and the ACS410 was interrupted for more than 30 seconds
	33	Manual locking after PC software reset attempt	PC software made a reset attempt although the system worked correctly
168	#	Internal error management	Make a reset; if error occurs repeatedly, replace the unit
169	#	Internal error management	Make a reset; if error occurs repeatedly, replace the unit
170	#	Internal error management	Make a reset; if error occurs repeatedly, replace the unit
171	#	Internal error management	Make a reset; if error occurs repeatedly, replace the unit
200 OFF	#	System error-free	No error

Error code	Diagnostic code	Meaning for the LMV37.4... system	Remedy
201	#	Start prevention	
OFF UPr			Start prevention due to unparameterized unit Go to error history, entry 702, for initial cause of the error with shutdown in connection with the first curve settings
	Bit 0	No operating mode selected	
	Valency 1		
	Bit 1	No fuel train defined	
	Valency 2..3		
	Bit 2	No curves defined	
	Valency 4..7		
	Bit 3	Standardized speed undefined	
	Valency 8..15		
	Bit 4	Backup / restore was not possible	
	Valency 16..31		
202	#	Internal error operating mode selection	Redefine the operating mode (parameter 201)
203	#	Internal error	Redefine the operating mode (parameter 201). Make a reset; if error occurs repeatedly, replace the unit
204	Phase number	Program stop	Program stop is active (no error)
205	#	Internal error	Make a reset; if error occurs repeatedly, replace the unit
206	0	Inadmissible combination of units (basic unit - AZL2...)	
207	#	Version compatibility basic unit - AZL2...	
	0	Basic unit version too old	
	1	AZL2... version too old	
208	#	Internal error	Make a reset; if error occurs repeatedly, replace the unit
209	#	Internal error	Make a reset; if error occurs repeatedly, replace the unit
210	0	Selected operating mode is not released for the basic unit	
240	#	Internal error	Make a reset; if error occurs repeatedly, replace the unit
245	#	Internal error	Make a reset; if error occurs repeatedly, replace the unit
250	#	Internal error	Make a reset; if error occurs repeatedly, replace the unit

8. Installation

8.1 General instructions

Installation must be carried out in accordance with current regulations and instructions.

The supplier/installer of the facility is obliged to familiarize himself with all regulations so that the installation meets the requirements of the local authorities.

Installation, assembly and settings must be performed to obtain the best possible function. Only gas intended for the gas burner may be used.

8.2 Instructions

It is the installer's responsibility to instruct the user in detail in the functions of the gas burner and the entire system.

8.3 Inspection and maintenance

The system must be maintained at the interval specified in the service schedule. If the burner is in a dirty environment, service should be done at more frequent intervals.

8.4 Preparation for assembly

Check that the burner's dimensions and capacity range match the current boiler. The power information on the type plate refers to the burner model's min. and max. effect.

8.5 Gas supply

In order to obtain good operational safety, it is important that the installation of the gas distribution system is carried out correctly, considering the following:

- Check that the burner is approved for the gas quality of the installation.
- Check that the burner gas components are approved for the specified gas pressure, see type plate.
- Installation must be carried out in accordance with current standards.
- Pipe lines should be assembled so that service can easily be performed on the boiler and burner.
- Pipe lines should be assembled so that any contaminants do not come into contact with the gas components.

8.6 Electric connection

- Before work on the electrical connection, the current must be disconnected so that the installation is isolated.
- Connection must be done in accordance with the applicable regulations.
- Connection must conform to the wiring diagram.



If any electrical connection other than that recommended by CTC is used, there is a risk of property damage and personal injury.

8.7 Handling and lifting instruction

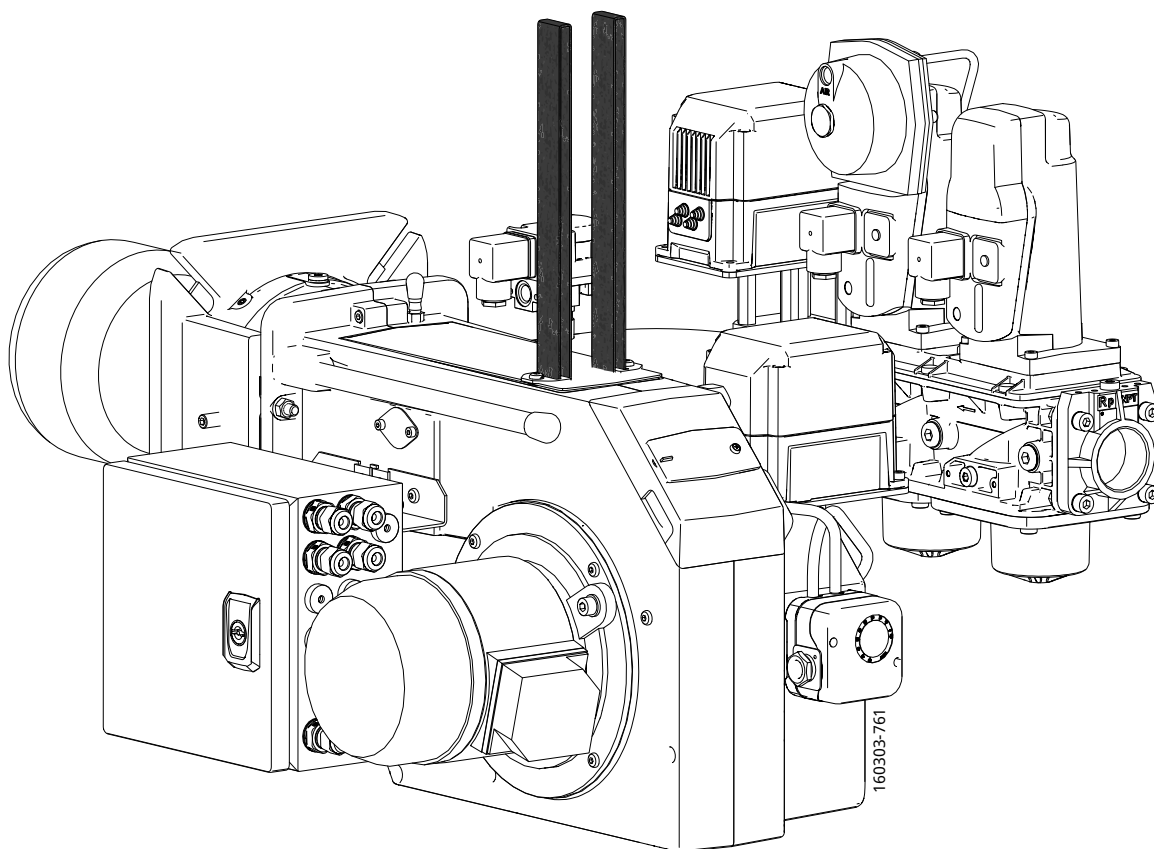

i The lifting aid are available as accessories.

9. Mounting

Mount the burner to the boiler using 4 bolts (if new fixing holes need to be drilled, use the fixing flange as a template).

Separate the fixing flange from the fan housing as follows:

1. Remove cover of fan housing (A), disconnect ignition and ionizing cables and the control arm (B) from nozzle assembly.
2. Disconnect the electrical cable to the gas valve.
3. Loosen nuts on both sides of the fixing flange.
4. Loosen end stop (C) for guides.
5. Pull the fixing flange with flame tube, nozzle assembly and gas fitting out of the fan housing.
6. Check that the ignition electrodes are correctly set, see chapter Gas nozzle.
7. Fit the enclosed gasket to the flame tube.
8. Screw the fixing flange and the enclosed gasket onto the boiler, lift the fan housing onto the guides and mount in reverse order.
9. Connect the gas line, connect the supply cable, operating and safety circuits.



Before obtaining access to electrical and fuel line components all supply circuits must be disconnected.

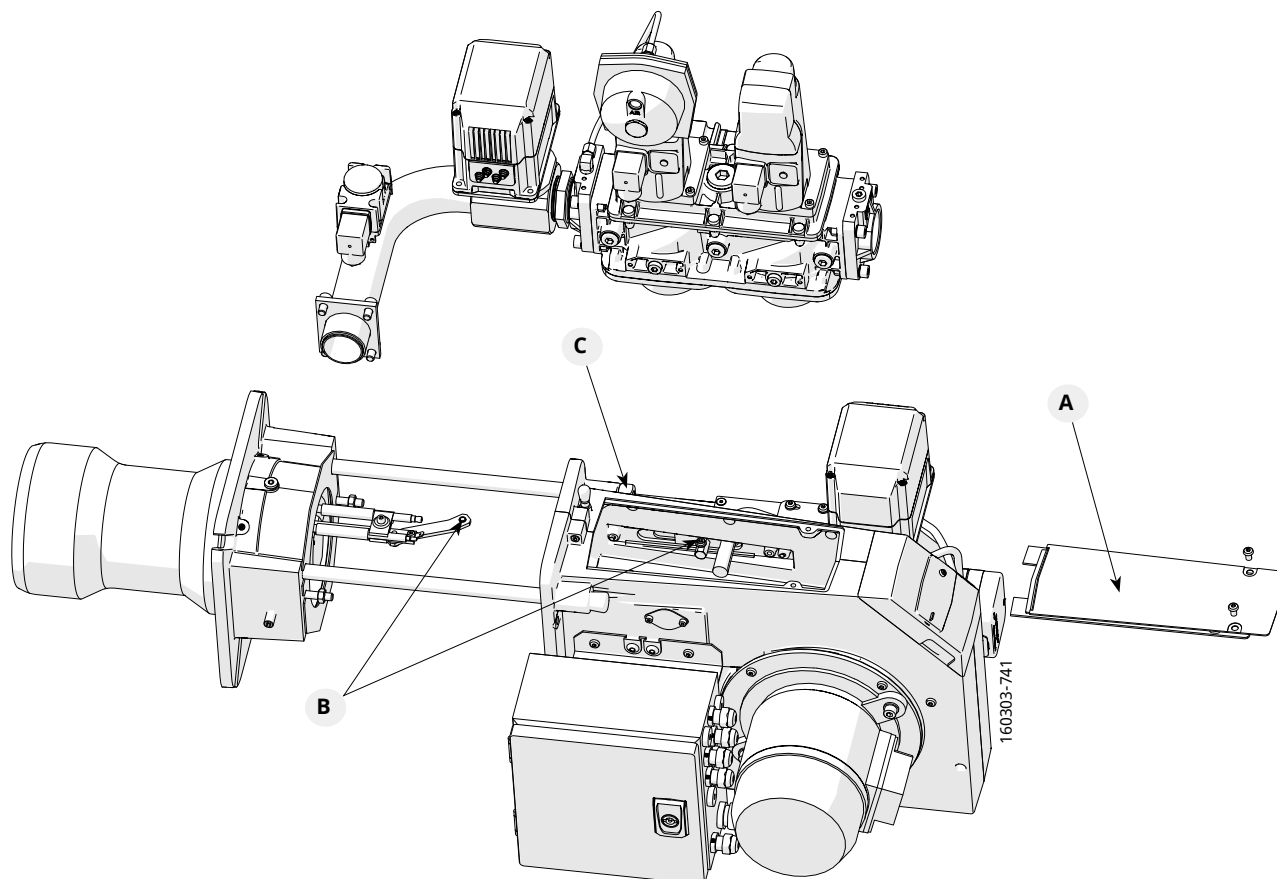

9.1 Gas nozzle

Check that the ignition electrodes are correctly set before mounting on the boiler.

Natural gas

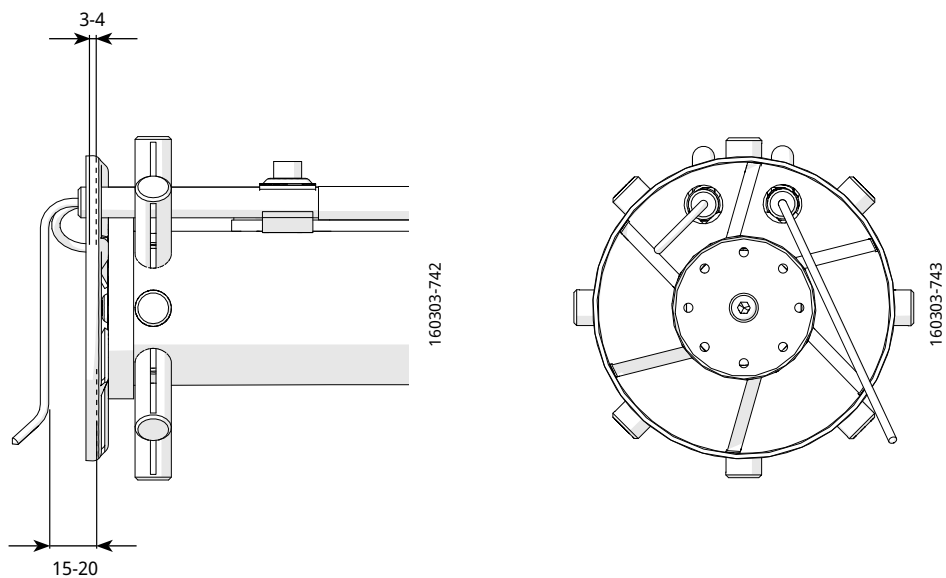

Propane

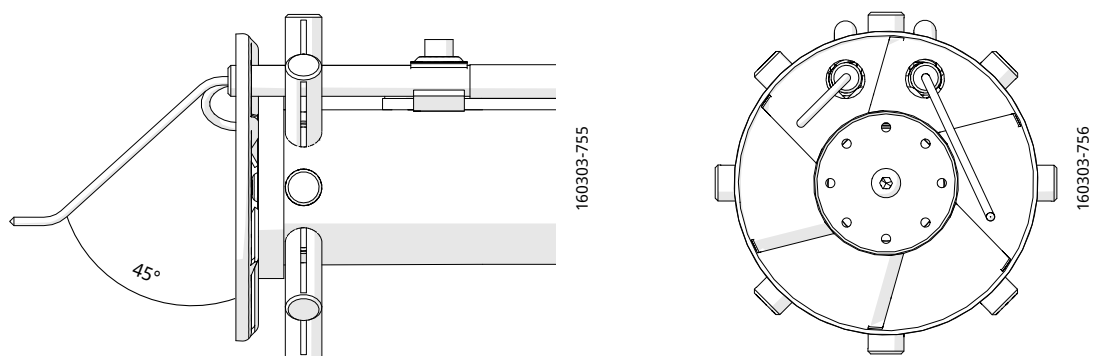

Biogas (UV detector)

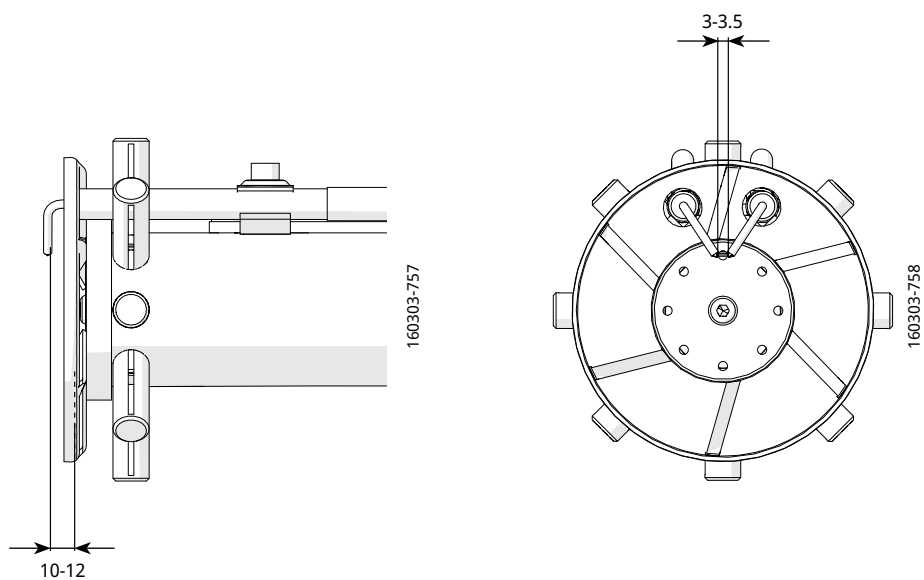

9.2 De-aerating

De-aerating the gas line by closing the tap to the gas connection and unscrewing the screw on the measuring nipple for the connection pressure. Connect a plastic hose, open the tap and drain the gas in a safe place. When the de-aerating is completed, be sure to refit the screw on the measuring nipple.

9.3 Leakage control

When checking for leakage, the solenoid valve must be closed. A pressure gauge is connected to the measuring nipple "Pm", see picture. The test pressure in the system must not be higher than max. connection pressure, see data plate. Also check the tightness at the filter "Pi". If leaks are found during measurement, locate the source using soapy water or leak detection spray. After sealing: check the leakage of the gas fixture again.



Check for leaks in the gas line.

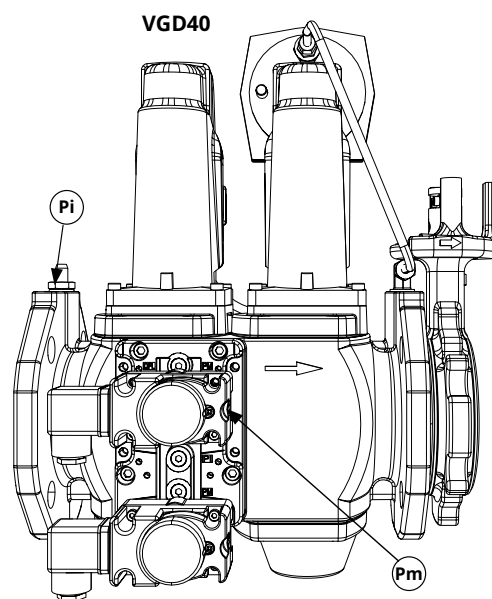
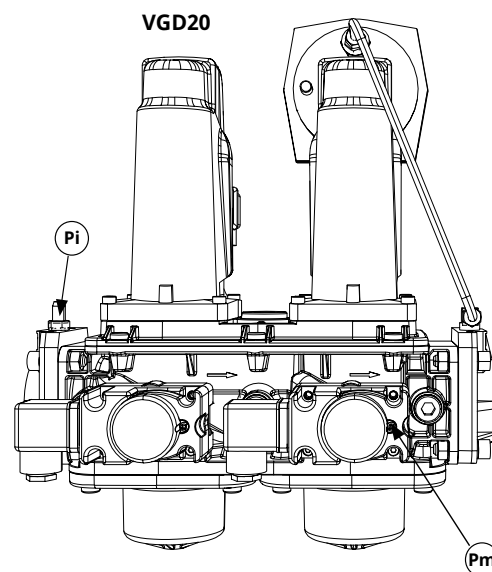

9.4 Calculate prepurge time, Industrial applications

Prepurg time can be set on control unit LMV with parameter 225.

Formula symbol	Description	Example values
V	Volume fire box [m ³]	3.8 m ³
Q	Burner output [kW]	380 kW
T	Prepurg time [s] Industrial applications according to EN 746. The prepurg time must correspond to at least 5 complete air circulations in the fire box and adapted compartments.	

Calculate prepurge time using the following formula:

$$T = \frac{V \cdot 5}{Q \cdot 1.2 / 3600} \quad T = \frac{3.8 \text{ m}^3 \cdot 5}{380 \text{ kW} \cdot 1.2 / 3600} = 150 \text{ s}$$

9.5 Calculation of gas flow

Formula symbol	Description	Example values
V_N	Standard gas volume [Nm ³ /h] Gas volume at normal condition 15 °C 1013 mbar	-
Q	Boiler output [kW]	380 kW
H_i	Lower calorific value of gas [kWh/m ³] Natural gas under normal conditions 15 °C 1013 mbar, EN 676	9.45 kWh/m ³
η	Boiler efficiency (e. g. 90%)	0.9
f	Conversion factor (pressure and temperature compensation)	-
t_{Gas}	Gas temperature at gas meter [°C]	15 °C
P_{Baro}	Barometric air pressure [mbar]	945 mbar
P_{Gas}	Pressure of gas at the gas meter [mbar]	20 mbar
V	Operating volume [m ³ /h]	-
VG	Gas flow measured at the gas meter [m ³]	1.28 m ³
T	Measuring time for consumed gas quantity [s]	93 s

Calculate standard volume using the following formula:

$$V_N = \frac{Q}{\eta \cdot H_i} \quad V_N = \frac{380 \text{ kW}}{0.9 \cdot 9.45 \text{ kWh/m}^3} = 44.7 \text{ m}^3/\text{h}$$

Calculate conversion factor using the following formula:

$$f = \frac{273}{273 + t_{Gas}} \times \frac{P_{Baro} + P_{Gas}}{1013} \quad f = \frac{273}{273 + 15} \cdot \frac{945 + 20}{1013} = 0.90$$

Calculate gas volume using the following formula:

$$V = \frac{V_N}{f} \quad V = \frac{44.7 \text{ m}^3/\text{h}}{0.90} = 49.5 \text{ m}^3/\text{h}$$

Determine operating volume with the following formula:

$$V = \frac{3600 \cdot V_G}{T} \quad V = \frac{3600 \cdot 1.28 \text{ m}^3}{93 \text{ sek}} = 49.5 \text{ m}^3/\text{h}$$

Height above sea level [m]	0	100	200	300	400	500	600	700	800	900	1000	1100	1200
P_{Baro} [mbar]	1013	1001	989	977	966	954	943	932	921	910	899	888	877

Calorific value of the gas

Gas quality		kWh/Nm ³	MJ/Nm ³
Natural gas	G20	9.5	34.02
Natural gas	G25	8.2	29.25

Gas quality		kWh/Nm ³	MJ/Nm ³
Butan	G30	32.25	116.09
Propan	G31	24.44	88.00
Biogas		6.0	21.60

Lower calorific value H_i at normal conditions 15 °C and 1013 mbar, EN 676.
For exact calorific value of the gas, contact the gas distributor.

10. Settings

10.1 Brake plate adjustment

The burner is equipped with a lever that changes the position of the brake plate in the combustion head. This is used to set the correct pressure drop across the combustion assembly and thereby obtain good combustion without ripples.

Make the adjustment by turning screw X.

The best position is, among other things, dependent on the input power and overpressure in the boiler.

A general rule of thumb is that the smaller the capacity, the smaller the gap should be between the brake plate and the combustion assembly.

The position of the brake plate also has an impact on the quantity of air supplied for combustion. This means that once the brake plate has been adjusted, the combustion should be checked and, if necessary, the setting of the air damper adjusted to obtain good combustion.

A left turn opens the brake plate, providing a lower pressure drop and more air to the combustion process.

A right turn closes the brake plate, providing a higher pressure drop and less air to the combustion process.

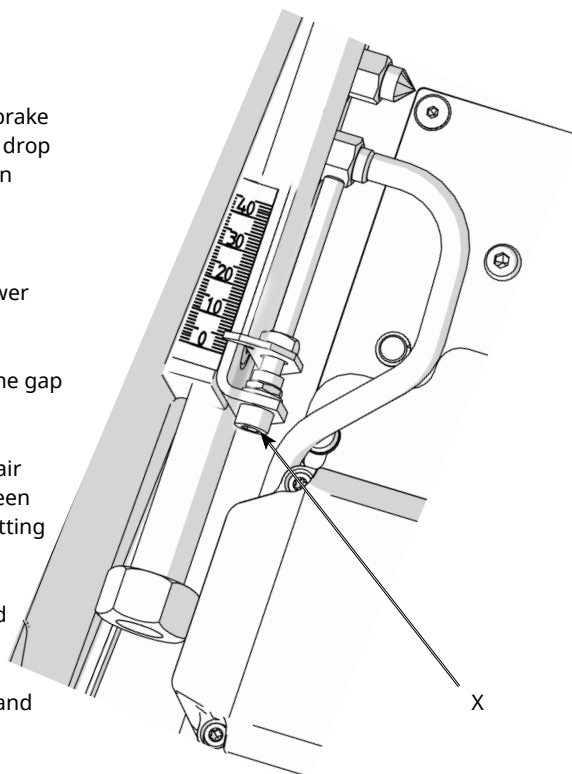

10.2 Setting the air damper

The position of the air damper must be adjusted to achieve a suitable fuel-air mixture in the operational events that are programmed.

For settings, see chapter LMV37.

10.3 Setting the gas damper

The position of the gas damper must be adjusted to achieve the desired minimum and maximum input power.

For settings, see chapter LMV37.

10.4 Startup

After the burner has been mounted on the boiler and the electrical connection, de-aeration and tightness control have been performed, the burner is ready to start-up.

Read the sections dealing with settings of gas valve, damper motor and combustion device before start-up.

Open the ball valve and turn on the main switch, start the burner and begin setting up the system.

10.5 Control of combustion

Check combustion using flue gas analysis instruments. Set the burner to about 20% excess air and check that good combustion is obtained. Check the actual gas flow on the gas meter to ensure that the correct input power is achieved.

Recommended air excess at basic setting

Gas quality	Excess air flue gases% O ₂
Natural gas	4 ±1
Propane	
Butane	
Liquefied petroleum gas	
Biogas	

8.7 Setting the air pressure switch

The air pressure switch must block the burner if the amount of air for combustion becomes too low. The air pressure switch must be set so that in the event of a lack of air supply at the burner's max. or min. capacity reacts before the monitored pressure drops so much that poor combustion occurs.

1. Remove protective cover.

! Be careful when adjusting the air pressure switch; it contains a live component.

2. Start the burner.
3. Carefully turn the scale on the air pressure switch clockwise until the air pressure switch stops the burner.
4. Measure and note the lowest air pressure in the entire work area.
5. Set the air pressure switch to about 10-15% lower than the lowest noted pressure.
6. Test run the burner and check the function in the entire work area.
7. Refit protective cover.



10.7 Setting the gas pressure switch, min.

The gas pressure switch must react to too low a connection pressure to the burner, prevent the burner from starting and stop the burner during operation. Start can only be done by manual reset (gas burner control or pressure switch).

1. Remove protective cover.
2. Open measuring socket and connect a manometer for measuring connection pressure.
3. Start the burner.
4. Measure and note the connection pressure to the burner at the highest input power.
5. Set the gas pressure switch to a value 10-15% lower than the noted pressure.
6. Check the setting by carefully closing the ball valve and at the same time measuring the connection pressure.
7. When the gas pressure switch stops the burner, the measured value must approximately correspond to the setting on the gas pressure switch.
8. Open ball valve.
9. Remove manometer and close measuring socket.
10. Refit protective cover.



Check gas tightness.

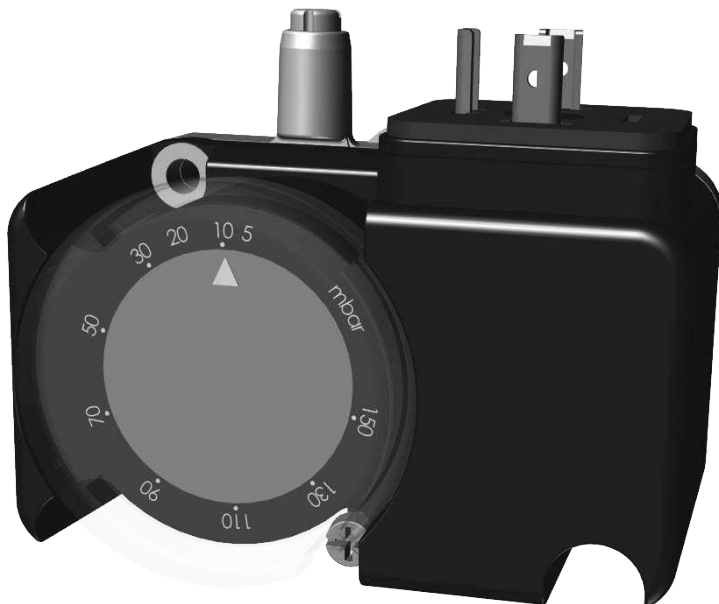

10.8 Setting the gas pressure switch max/ overload protection switch

The gas pressure switch must react to excessive gas pressure in the burner. Start can only be done by manual reset (gas burner control or pressure switch).

The switch blocks the burner if gas pressure between gas valve and burner becomes too high.

1. Remove protective cover.
2. Open measuring socket and connect a manometer for measuring connection pressure.
3. Start the burner.
4. Measure and note the highest gas pressure in the entire work area.
5. Set the gas pressure switch to a value 10-15% lower than the noted pressure.
6. Test run the burner and check the function in the entire work area.
7. Remove manometer and close measuring socket.
8. Refit protective cover.



Check the gas tightness.



10.9 Setting the gas pressure switch VPS

Gas pressure switch VPS is used to detect leaky gas valves.

1. Remove protective cover.
2. Open measuring socket and connect a manometer for measuring connection pressure.
3. Start the burner.
4. Measure and note lowest and highest gas pressure during start-up.
5. Set the switch to a value between these values.
6. Test run the burner and check the function in the entire work area.
7. Remove manometer and close measuring socket.
8. Refit protective cover.



Check the gas tightness.

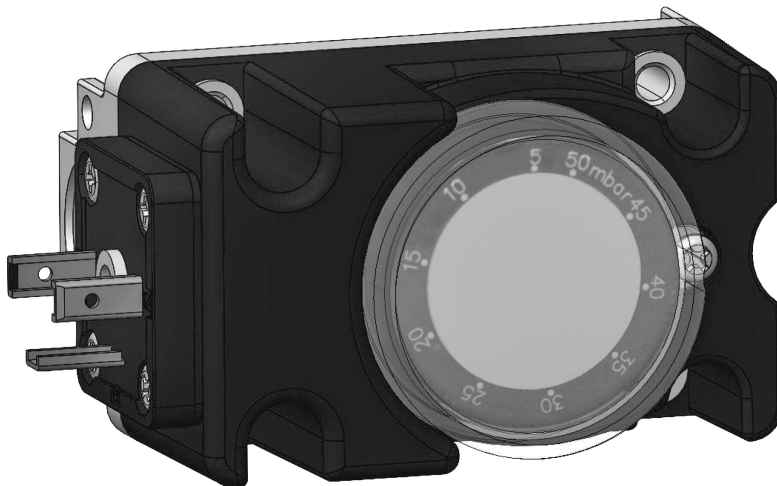

11. Gas valve VGD20... SKP15/25



All components must be installed without being bent, twisted or subjected to mechanical or thermal forces which can affect the components.

11.1 Technical specification

Adjustable regulator pressure:		
VGD20.xx/SKP15/25 with spring AGA 29		≤ 22 mbar (Unpainted)
VGD20.xx/SKP15/25 with spring AGA 22		15 - 120 mbar (Yellow/Gold)
Dirt trap		Built in (mesh size 0.9 mm)
Solenoid valve V1	SKP15	opening time varies with valve size, 14 s for max stroke closing time <0,8 s.
Solenoid valve V2	SKP25	opening time varies with valve size, 14 s for max stroke closing time <0,8 s.
Voltage / Frequency		50 - 60 Hz 220 - 240 V AC -15 % +10 %
Switch-on duration		100%
Degree of protection		IP54
Environmental conditions:		
Temperature range		-10...60 °C
Humidity		<95% r.h.
Gas qualities		Suited for use with gases of gas families I...III and air. Suitable for gases up to max. 0.1 Vol.-% H ₂ S, dry

11.2 Overview

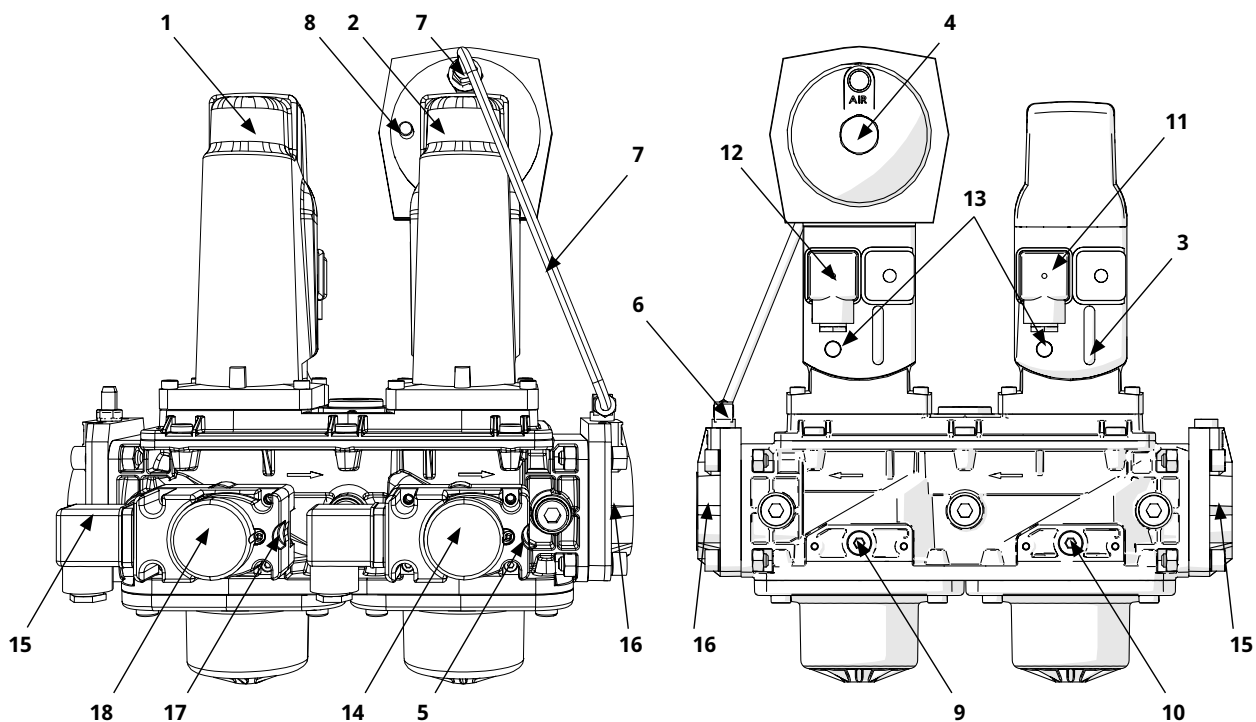

- | | | | |
|----|--|-----|---------------------------------------|
| 1. | V1 SKP15 | 10. | Connection Pi |
| 2. | V2 SKP25 | 11. | Electrical connection gas valve V1 |
| 3. | Valve opening position | 12. | Electrical connection gas valve V2 |
| 4. | Adjustment pressure regulator | 13. | Indication of V1 and V2 in operation |
| 5. | Measuring nipple pressure switch, VPS/Pm | 14. | Pressure switch, VPS |
| 6. | Connection 1/4" pG | 15. | Flange connection inlet |
| 7. | Impuls tube pG | 16. | Flange connection, outlet |
| 8. | Test nippel pG
(measurement of pressure after V2) | 17. | Measuring nipple pressure switch, min |
| 9. | Connection Pm | 18. | Pressure switch, min |

A gas pressure switch for monitoring that the connection pressure does not get too low is mounted on the gas valve so that it can be used both as a gas pressure switch and to check for tightness.

11.3 Installation position

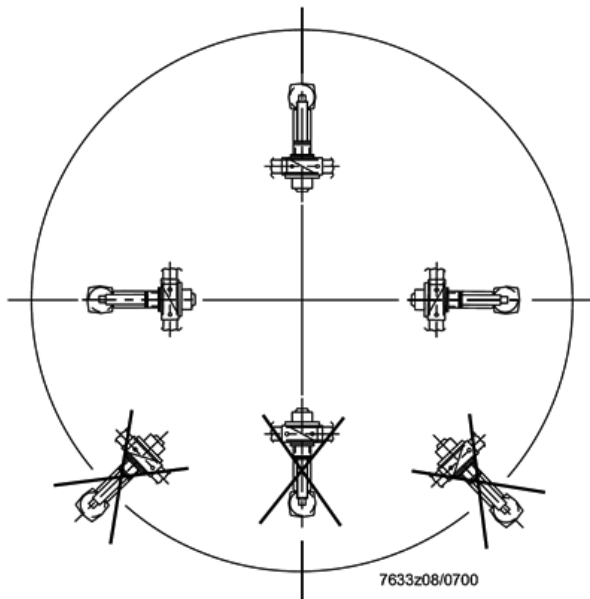

11.4 Adjusting the gas valve

When the gas valve is used together with the LMV37 control unit with butterfly valve on the gas pipe, the gas valve acts as a clean valve, which is not used to set the correct gas flow. However, some adjustment of the gas valve may help to achieve robust burner function. The regulator on the gas valve should be set in such a way that the input pressure is reduced using the regulator; this ensures that any variation in the input pressure will not affect the pressure leaving the valve.

11.5 Actuator SKP15

SKP15 is mounted on the first valve of the gas valve in the direction of gas flow. The only function of this actuator is open/close.

11.6 Actuator SKP25

SKP25 is mounted on the second valve of the gas valve in the direction of gas flow. This actuator has two functions: open/close and controlling the gas pressure leaving the gas valve.

11.6.1 Adjusting the pressure regulator on actuator SKP25

1. Remove protective plug X.
2. Adjust the pressure regulator by turning the adjuster screw with the slotted screwdriver to the desired output pressure in Pa, see image. Turning to right = higher regulator pressure Turning to left = lower regulator pressure
3. Fit protective plug X.
Possible output pressure range 15–120 mbar.
Pressure is measured at the pressure outlet on SKP25. See section 10.2.2.

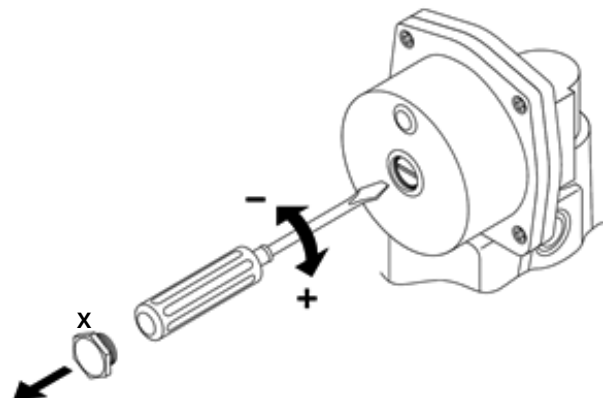

11.6.2 Replacing the spring on the pressure regulator for an SKP25 actuator

The SKP25 actuator is fitted with an AGA29 type spring for the regulator at the factory.

1. Remove protective plug X.
2. Remove pressure regulator screw Y.
3. Take out the spring and replace it.
4. Fit pressure regulator screw Y and set to the desired regulator pressure.
5. Fit protective plug X.

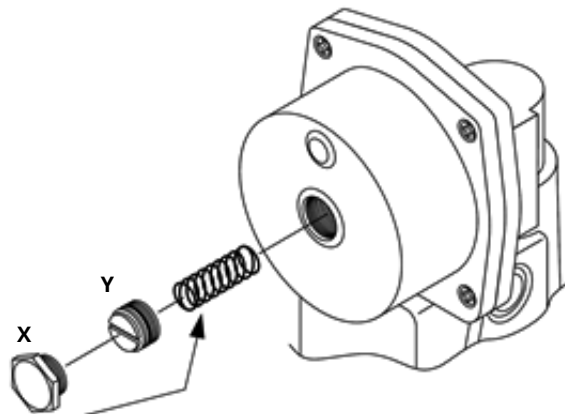

11.6.3 Impulse pipe for pressure regulator SKP25

On gas valve VGD20.../SKP15/25 there is an impulse pipe for the nozzle pressure which is necessary for regulator SKP25 to function properly. The impulse pipe has an inside diameter of 4 mm and an outside diameter of 6 mm. The impulse pipe for the nozzle pressure to the regulator is fitted at the factory. When replacing the impulse pipe, a steel pipe must be used with an inside diameter > 4 mm. The impulse pipe must be protected against breakage and damage. If damage should occur, the impulse pipe must be replaced before the burner is put into operation again.

11.7 Gas damper VKG



All components must be installed without being bent, twisted or subjected to mechanical or thermal forces which can affect the components.

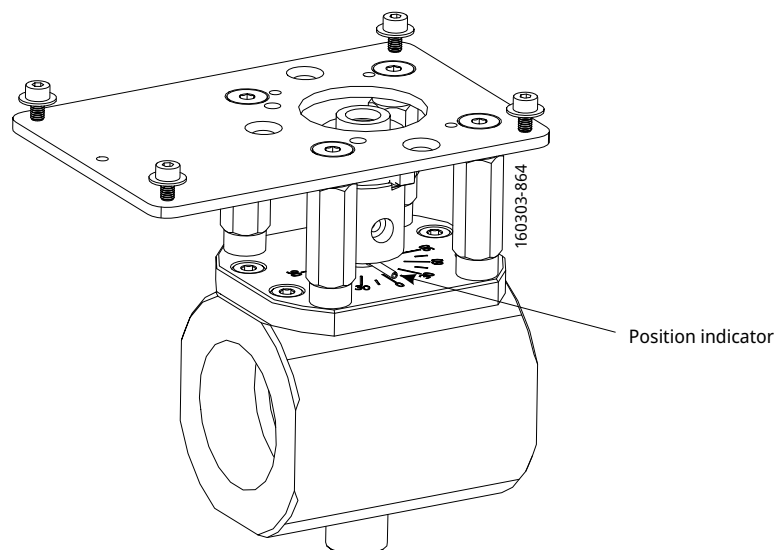

- When performing installation and service, check whether the gas damper is in the closed position (0) when the burner is turned off. See image.
- When installing a gas damper, observe the direction of flow shown on the gas damper.
- After working on a gas damper, check the gas tightness.

11.8 SQM Damper motor

An SQM33 damper motor with adjustable rotational direction is used on the burner to control gas and air volumes.

11.8.1 Technical specification

Torque	up to 3 Nm nominal output torque
Cable length:	
SQM33.510...	1,5 m
SQM33.511...	3,0 m
Power consumption Max.	10 W
Degree of protection	IP54
Rated resolution encoder monitoring	0.7°
Environmental conditions:	
Temperature range	-20...+60 °C
Humidity	<95% r.h.

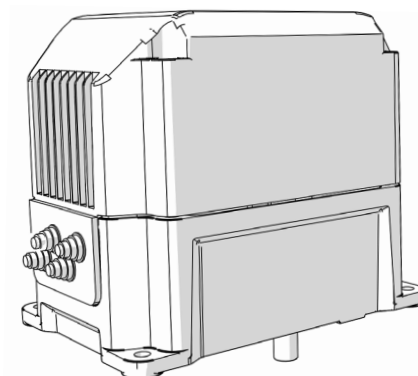

11.8.2 Important to remember

- When servicing/replacing a damper motor, select the correct motor for the desired control as the direction of rotation varies.
- When servicing/replacing a damper motor, clean it and check that the damper is not sluggish to avoid problems with the damper motor not managing to make adjustments.
- The tightening torque of 1.5 Nm for the fixing screws must not be exceeded to prevent damage to the actuator and to ensure that the actuator does not twist on its mounting surface
- When mounting the actuator, ensure that the permissible axial and radial loads on the bearing are not exceeded
- When fitting the actuator to the controlling element, the correct mounting order must be observed. It is usually as follows:
 1. Damper motor SQM must be connected and supplied with power before installation to ensure that the motor shaft and direction of rotation are set correctly.
 2. Screw on the actuator
 3. Connect the actuator's drive shaft to the controlling element using the coupling pin screw.
- The actuators are supplied with attached connecting cable and plug
- One-time bend when laying the cable: 2 x cable diameter
- Always run the high-voltage ignition cables separate from the unit and other cables while observing the greatest possible distance.
- The holding torque is reduced when the actuator is disconnected from power.

12. Service

Service and maintenance work may only be performed by qualified personnel. Perform operational check of all safety systems and components at each service. Only CTC original parts should be used when replacing components.



Use caution when operating the burner, surfaces may be hot.



12.1 Burner Service Schedule, Gas

Servicing must be carried out once a year or after 3,000 hours of operation.

Burner	1 year	3,000 h
Inspection of electrical installation	1 year	3,000 h
Leak check	1 year	3,000 h
Filter	1 year, replacement at $\Delta p > 10$ mbar	3,000 h, replacement at $\Delta p > 10$ mbar
Electrodes	Replacement/cleaning 1 year	Replacement/cleaning 3,000 h
Brake plate	Replacement/cleaning 1 year	Replacement/cleaning 3,000 h
Motor	1 year	3,000 h
Fan wheel	1 Year Replace if need for cleaning/imbalance	3,000 h Replace if need for cleaning/imbalance

12.2 Component replacement intervals

Components	Service life - Recommended replacement	Service life - Recommended replacement Operating cycles
Control system	10 years	250,000 starts
Valve control system	10 years	250,000 starts
Pressure switch	10 years	250,000 starts
Ignition system with flame guard	10 years	250,000 starts
UV flame sensor	10,000 h	N/A
Gas pressure controls	15 years	N/A
Gas valve without leak testing	10 years	250,000 starts
Gas valve with leak testing	Replacement upon fault detection	N/A
Gas pressure switch	10 years	250,000 starts
Safety blow-off system	10 years	N/A
Damper motor	N/A	500,000 starts
Contactors	10 years	500,000 starts



The burner and its components must be recycled according to applicable regulations.

12.3 Combustion device

1. Disconnect the main power and shut off the fuel supply.

! Before obtaining access to electrical and fuel line components all supply circuits must be disconnected.

2. Remove cover (A), disconnect ignition and ionization cables and control arm (B) from nozzle assembly.
3. Loosen nuts (C) and pull out the fan housing on the guides.
4. By loosening screw (D), the combustion device is released and can be lifted out from the burner.
5. Check and clean the brake plate and gas inlet, replacing components as necessary.
6. Check that the ignition and ionisation electrodes are correctly set, (see Gas nozzle chapter) - replace if necessary.
7. Refit the combustion device in reverse order.
8. Press the burner together and lock with nut (C).
9. Switch on the main power and open the fuel supply.
10. Start burner and check/adjust combustion.

! Check for leaks in the gas line.

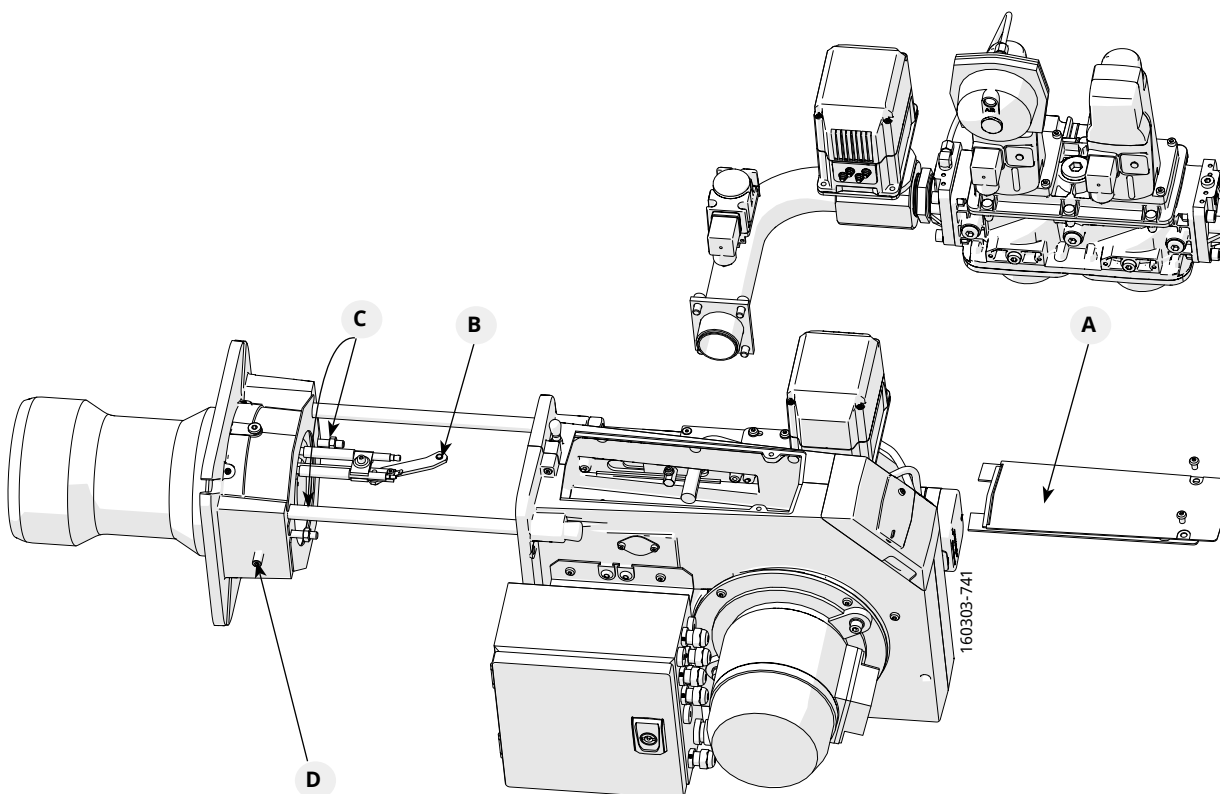

! When servicing/replacing components that affect combustion, flue gas analysis and soot test must be carried out following installation.

12.4 Air damper

1. Disconnect the main power and shut off the fuel supply.



Before obtaining access to electrical and fuel line components all supply circuits must be disconnected.

2. Remove cover (A), disconnect ignition and ionization cables and control arm (B) from nozzle assembly.
3. Loosen nuts (C) and pull out the fan housing on the guides.
4. Remove the intake grille (E) to the air intake.
5. Remove the screws (I) holding the damper motor and loosen screws (F) to the damper motor mounting plate.
6. Lift up the damper motor and mounting plate.
7. Clean the air damper and air intake, lubricate the damper shaft if necessary.
8. Refit the damper motor and mounting plate, ensuring that the damper shaft and control arm are correctly connected.
9. Adjust the home position for the damper motor by moving the damper motor back and forth in the adjustment groove. Lock the damper motor with screws (I), in a position where the damper is close to the mechanical stop in the fan housing but still has a small air gap.
10. Fit the intake grille.
11. Press the burner together and lock with nut (C).
12. Switch on the main power and open the fuel supply.
13. Start burner and check/adjust combustion.

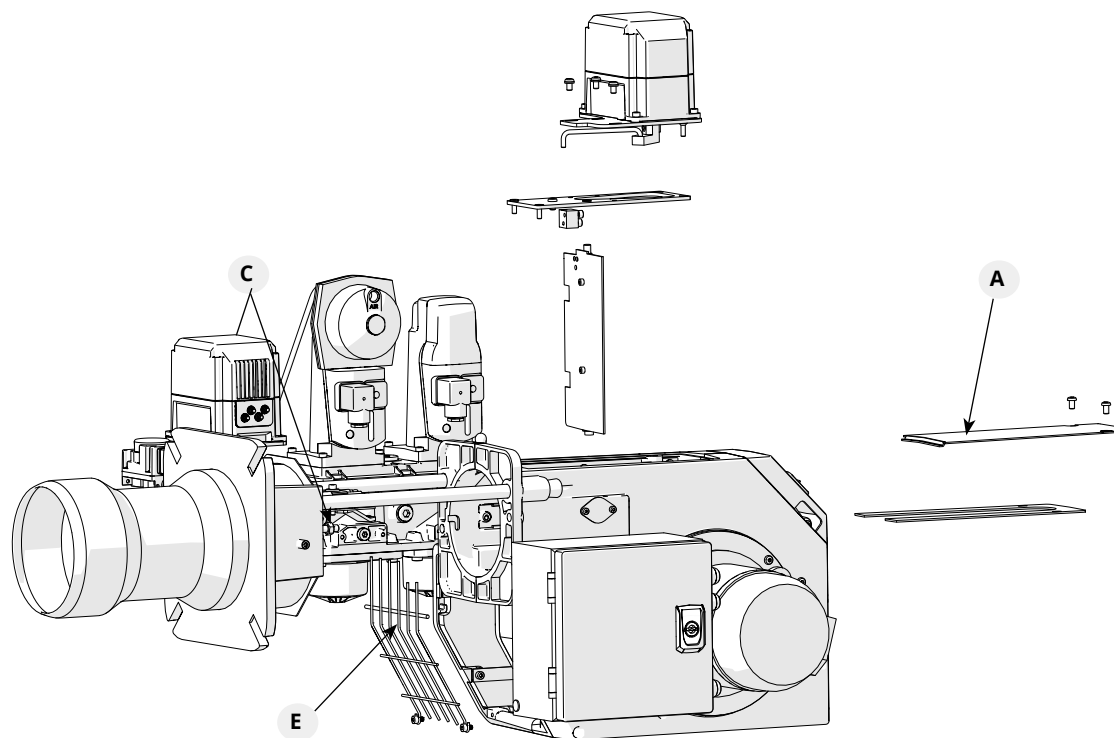

12.5 Replacement of damper motor, air

1. Disconnect the main power and shut off the fuel supply.

! Before obtaining access to terminals, all supply circuits must be disconnected.

2. Disconnect the damper motor cable from the automatic control unit.
3. Remove the screws (I) holding the damper motor and loosen screws (F) to the damper motor mounting plate.
4. Lift up the damper motor.
5. Remove (H) the control arm from the motor shaft.
6. Remove the damper motor from the mounting plate (J).
7. Install the new damper motor on the mounting plate.

! Damper motor SQM must be connected and supplied with power before installation to ensure that the motor shaft and direction of rotation are set correctly.

8. Fit the control arm on the damper motor shaft. It is important that the screw is perpendicular to the plane of the shaft.
9. Refit the damper motor and mounting plate on the air intake. Ensure that the damper shaft and control arm are connected correctly.
10. Connect the damper motor cable to the automatic control unit.
11. Switch on the main power.
12. Adjust the home position for the damper motor by moving the damper motor back and forth in the adjustment groove. Lock the damper motor with screws (I), in a position where the damper is close to the mechanical stop in the fan housing but still has a small air gap.

! NOTE! When resetting dampers, ensure that they do not engage in the close damper position. If dampers do engage, the automatic control unit will report an error message.

13. Disconnect the main power.
14. Complete the burner assembly.
15. Switch on the main power and open the fuel supply.
16. Start burner and check/adjust combustion.

! When servicing/replacing components that affect combustion, flue gas analysis and soot test must be carried out following installation.

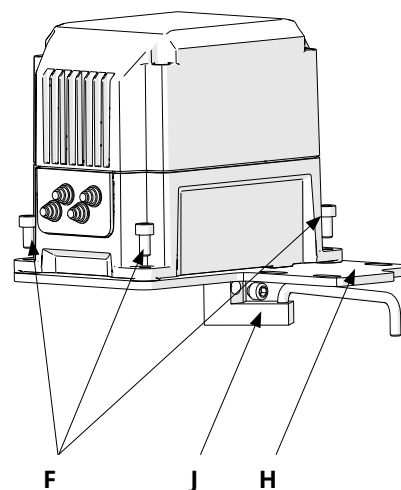
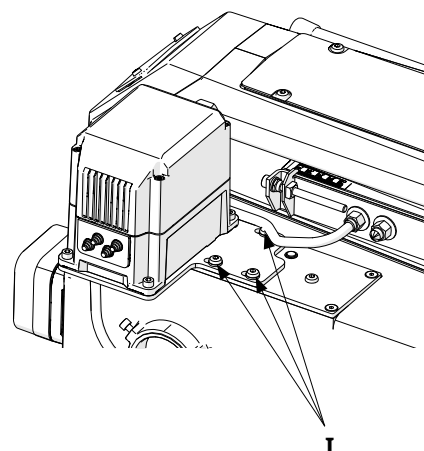

! Ensure that the shaft of the damper motor SQM is in the correct position.

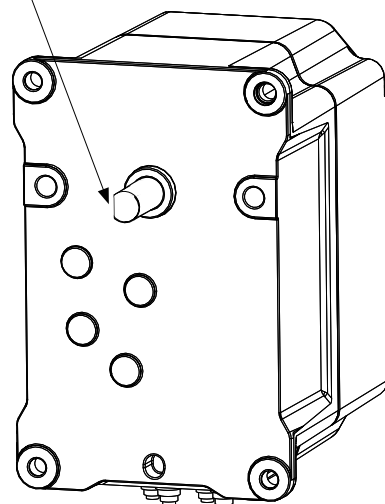

12.6 Replacement of damper motor, gas

1. Disconnect the main power and shut off the fuel supply.

! Before obtaining access to terminals, all supply circuits must be disconnected.

2. Disconnect the damper motor cable from the automatic control unit.
3. Undo the screw (Y) on the connection between the motor and damper.
4. Undo the screws (X) and remove the damper motor from its damper plate.

! Damper motor SQM must be connected and supplied with power before installation to ensure that the motor shaft and direction of rotation are set correctly.

5. Install the new damper motor, tighten the screws (X).
6. When tightening screw (Y), ensure that the damper is in the closed position.
7. Connect the damper motor cable to the automatic control unit.
8. Switch on the main power and open the fuel supply.
9. Start burner and check/adjust combustion.

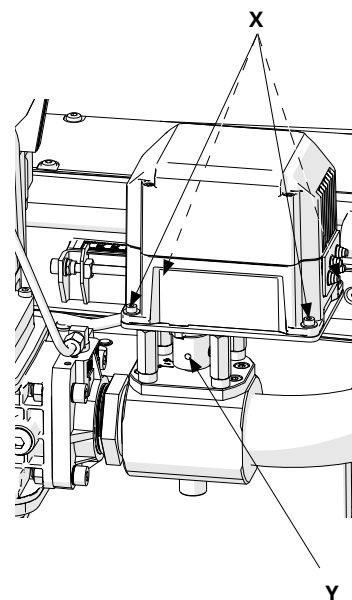

! Ensure that the shaft of the damper motor SQM is in the correct position.

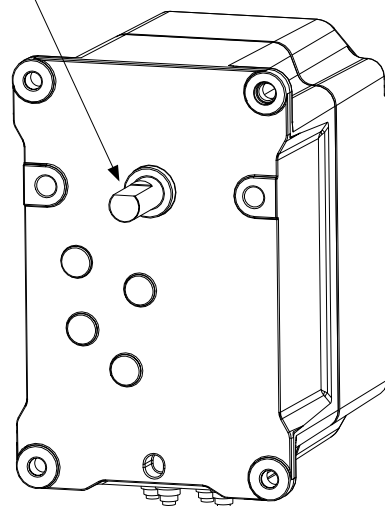

! When servicing/replacing components that affect combustion, flue gas analysis and soot test must be carried out following installation.

12.7 Fan

1. Disconnect the main power and shut off the fuel supply.



Before obtaining access to electrical and fuel line components all supply circuits must be disconnected.

2. Loosen the motor electrical connection and screws (X) enough to turn and lift out the motor.
3. Check the fan wheel attachment and any skew, replace if damaged.
4. Clean or replace the fan wheel.
5. Refit the parts.
6. Switch on the main power and open the fuel supply.
7. Start burner and check/adjust combustion.

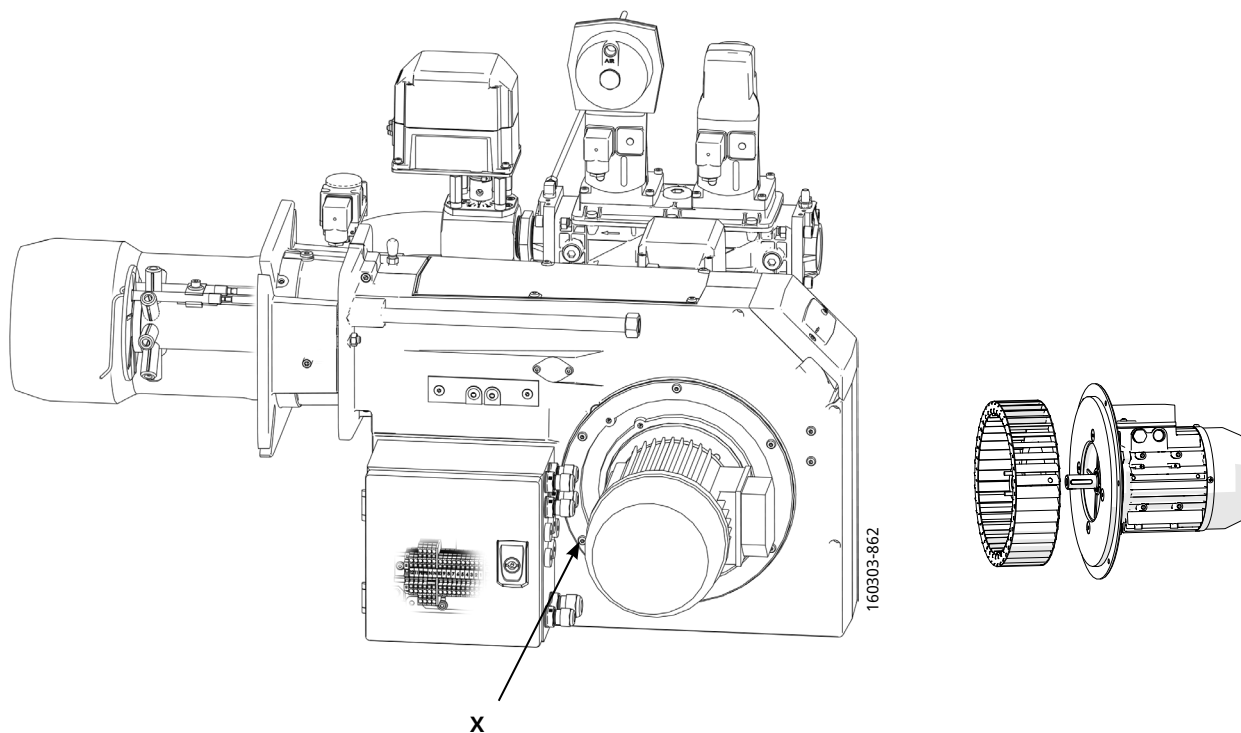

When servicing/replacing components that affect combustion, flue gas analysis and soot test must be carried out following installation.

12.8 Vibrations

Maximum permitted vibration level is 5.0 mm/s.

- Check tightness of fasteners.
- Check fan wheel for damage and contamination (replace if necessary).
- Check motor shaft and bearings. If they are worn, replace the motor.

Use the screw on the cover to attach the vibration sensor.

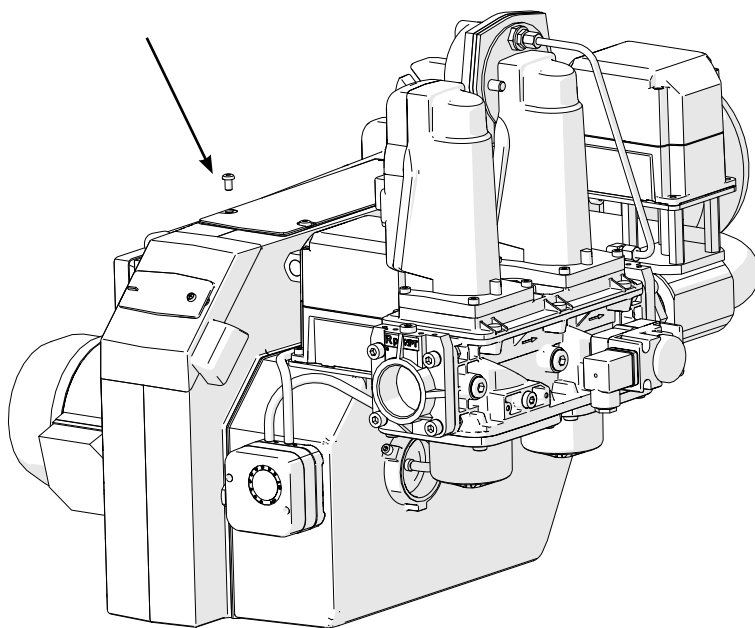

12.9 Kontroll av flamövervakning och joniseringsström

Brännaren är i standardutförande övervakad enligt joniseringsprincipen. Joniseringsströmmen skall kontrolleras vid uppstart och vid varje servicebesök.

Orsaken till för låg joniseringsström kan vara kryptströmmen, dålig anslutning till jord nedsmutsning eller att flamelektroden är felplacerad i brännarhuvudet. Ibland kan även fel gas- luftblandning orsaka för dålig joniseringsström.

Joniseringsströmmen mätes med en microampèremeter (μA) som inkopplas i serie med flamelektroden och gasautomaten.

Koppla in μA -metern enl. fig. Min erforderlig joniseringsström framgår av tabellen. I praktiken måste denna ström vara betydligt högre helst mer än $10 \mu A$. Inkopplingen av μA instrumentet underlättas av att alla gasbrännaren är försedda med delbar joniseringskabel.

Tekniska data

För kontinuerlig drift!

Tomgångsspänning vid ION-plint (X10-05 plint 2)	Ca. U-nät
 Skydda joniseringselektroden mot elektriska stötar!	
Kortslutningsström	Max. AC 1 mA
Erforderlig detektorström	Min. DC 4 μA , flamvisning ca 30%
Tillåten detektorström	Max. DC 16-40 μA , flamvisning ca 100%
Gränsvärden vid flamövervakning med joniseringselektrod:	
- Startspärr (främmande ljus)	Flamintensitet (parameter 954) $\geq 18\%$
- Drift	Flamintensitet (parameter 954) $\geq 24\%$

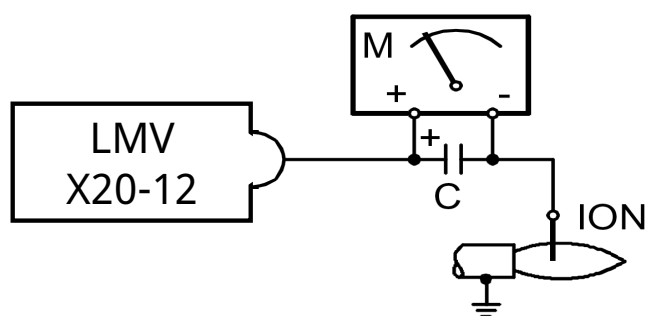

10.14 Replacement of electrical components

1. Disconnect the main power and switch off the fuel supply.



Before obtaining access to terminals, all supply circuits must be disconnected.

2. Note the connection of the existing component and disassemble.
3. Fit new component with same connection or with specified alternative connection.
4. Switch on the main power and check the operation of the new component.
5. Start burner and check/adjust combustion.



When servicing/replacing components that affect combustion, flue gas analysis and soot test must be carried out following installation.

13. Handing over of the installation

- Make repeated start attempts to ensure that the adjustments function.
- Close the ball valve during operation to check that the gas switch switches off at the set value.
- Remove the hose for the air pressure switch to check that the burner locks out.
- Check that all protective covers and measurement nipples are mounted and fastened.
- Fill out necessary test reports.
- Instruct the persons in charge of the operation on the service and maintenance of the installation and what to do should any troubles occur.
- Inspection and service must be carried out by authorized personnel.



Review and service should be performed by authorised personnel only.

14. Troubleshooting

Conditions favourable to trouble-free operation of the system can only be guaranteed through the interaction between three factors: electricity, gas flow and combustion air. If any of these factors change, it may cause a malfunction.

Before requesting servicing, check the following points:

1. Are the system's gas taps open?
2. Are the fuses intact and is the power on?
3. Are control devices (room thermostat, boiler thermostat, etc.) correctly set?
4. Is there sufficient gas pressure to the burner?
5. Are the burner controls on standby and not locked?
6. Is there sufficient air supply to the burner?

Cause of fault	Action
Burner does not start:	
No gas.	Make sure all gas taps are open.
No power.	Check the fuse, thermostat and electrical connections.
Burner motor does not start.	Motor protection has tripped. Motor faulty.
Burner control faulty.	Replace.

Burner motor running, no ignition spark at the end of pre-aeration:	
No power in the terminals.	Check the connector. Replace faulty burner controls.
Ignition electrodes in contact with each other or earth.	Adjust.
Ignition electrode porcelain damaged.	Replace the electrodes.
Poor connection to cable connectors.	Adjust connection.
Ignition cables damaged.	Replace.
Transformer damaged, no power to secondary winding.	Replace the transformer.
Ignition cable and ionisation cable swapped around.	Reconnect.

No flame propagation:	
Gas solenoid valve faulty.	Replace.
Gas solenoid valve does not open despite having power.	Replace solenoid valve terminals, or entire valve.
No power to solenoid valve.	Check the connection.
No electrical connection through air pressure gauge.	Check the air pressure gauge's settings and functions.
Ignition load incorrectly set.	Increase/decrease gas supply Reduce airflow.
Burner control faulty	Replace
Air pressure gauge incorrectly set or faulty	Check the settings and reset, or replace
No acknowledgement signal due to incorrect adjustment or misalignment of the control motor cams.	Check the settings and realign.

Burner trips after safety time limit despite flame propagation:	
No ionisation current or UV cell incorrectly positioned.	Adjust ionisation electrode and UV cell Check cables and connectors.
Burner control monitor faulty.	Replace burner control.
Voltage lower than 185V.	Contact an electrician.
Ignition electrodes disrupting ionisation current.	Adjust ignition electrodes. Re-polarise the transformer.
Poor earth connection.	Ensure adequate earth connection.
Phase and neutral swapped around.	Check wiring diagram and change accordingly.

Cause of fault	Action
Burner trips during pre-aeration:	
Air sensor faulty or incorrectly set.	Increase/decrease air setting. Reduce air volume.
Ignition load incorrectly set.	Increase/decrease gas supply Reduce airflow.
Gas pressure too low.	Increase pressure. If necessary, contact gas supplier.

Pulsations at start-up:	
Ignition electrodes incorrectly set.	Adjust .
Gas pressure too high.	Check and adjust using pressure gauge and pressure control valve.
Flue gas side blocked.	Check the chimney flue.

Burner pulsates during operation:	
Burner incorrectly set.	Adjust.
Burner dirty.	Clean the burner.
Incorrect chimney.	Check and modify dimensions if necessary.

Burner functioning properly but with occasional blockage:	
Ionisation current too low.	Check. Must be at least 6 μ A, but should ideally lie between 8-20 μ A.
UV cell incorrectly positioned.	Adjust.
Voltage drop at certain times.	Must not drop below 15% of rated voltage. Contact an electrician if necessary.
Incorrectly set or faulty air sensor.	Check the settings and reset, or replace.
Ignition electrode overload.	Replace.
Burner control ambient temperature too high.	Insulate for heat, Max. 60 °C.
Ignition spark too weak.	Check the transformer.

Poor combustion:	
Poor draught conditions.	Check the chimney.
Flue gas temperature too high.	Boiler overloaded Decrease the gas volume, sweep the chimney if necessary.
CO2 content too low.	Choke the air supply. Check the boiler for any leakages. Choke the draught if too high.

CO content too high:	
Surplus air when using natural gas and liquefied petroleum (propane, butane).	Choke the air supply.
Poor air supply.	Open the air supply. Check flue gas damper.
Holes in gas nozzle clogged.	Clean.
Poor fresh air intake.	Check and increase.
Flame at incorrect angle due to combustion head out of position.	Check the combustion head and readjust.

Condensation build up in boiler and chimney:	
Flue gas temperature too low or gas volume too low.	Raise the flue gas temperature by increasing gas volume Insulate the chimney.

15. Service- and inspection protocol

Installation:	Boiler:	
Name:	Type:	Efficiency kW:
Address:	Burner	
	Type:	Efficiency kW:
Installed by:	Date:	

Date	Nm ³ gas/h	Governor		CO ₂ %	CO %	Fluegas temp °C	Ionisation current µ A	Pressure		Efficiency %
		Before	After					Fire room mbar	Chimney mbar	
		Measurement								
	Small Flame									
	Large Flame									
	Measures									

Date	Nm ³ gas/h	Governor		CO ₂ %	CO %	Fluegas temp °C	Ionisation current µ A	Pressure		Efficiency %
		Before	After					Fire room mbar	Chimney mbar	
		Measurement								
	Small Flame									
	Large Flame									
	Measures									

Date	Nm ³ gas/h	Governor		CO ₂ %	CO %	Fluegas temp °C	Ionisation current µ A	Pressure		Efficiency %
		Before	After					Fire room mbar	Chimney mbar	
		Measurement								
	Small Flame									
	Large Flame									
	Measures									



EU Declaration of conformity

Bentone Gas Burners

Type:	Certificate No.	Type:	Certificate No.
BFG 1	CE-0123CT1269	BG 550	CE-0123CT1326
STG 146	CE-0123CT1281	BG 650	CE-0123CT1348
BG 300	CE-0123CT1292	BG 700	CE-0123CT1359
BG 400	CE-0123CT1304	BG 800	CE-0123CT1360
BG 450	CE-0123CT1315	BG 950	CE-0123CT1371

This declaration of conformity is issued under the sole responsibility of the manufacturer.
The object of the declaration described above is in conformity with:

- **Gas Appliance Regulation 2016/426/EU**
- **Machinery Directive 2006/42/EC**
- **LVD 2014/35/EU**
- **EMC 2014/30/EU**
- **The Restriction of the Use of Certain Hazardous Substances (RoHS) Directive 2011/65/EU**

References to the relevant harmonised standards used or references to the other technical specifications in relation to which conformity is declared:

EN 676:2020 Including the requirements of Annex K.
Automatic forced draught burners for gaseous fuels.

Additional information can be downloaded at: www.bentone.com

Manufacturer: CTC AB
Näsvägen 8
SE-341 34 LJUNGBY
Sweden

Notified Body: TUV SÜD Product Service GmbH
Ridlerstraße 65
D-80339 München, Germany
Notified Body Number: 0123

Ljungby, 2024-01-01

Joachim Hultqvist

Technical Manager
CTC AB

Ola Karlsson

Quality Manager
CTC AB

UK Declaration of conformity

Bentone Gas Burners

Type:

BFG 1	BG 400	BG 650	BG 950
STG 146	BG 450	BG 700	
BG 300	BG 550	BG 800	

This declaration of conformity is issued under the sole responsibility of the manufacturer.
The object of the declaration described above is in conformity with:

- **Gas Appliances (Enforcement) and Miscellaneous Amendment Regulations 2018**
- **Supply of Machinery (Safety) Regulations 2008**
- **Electrical Equipment (Safety) Regulations 2016**
- **Electromagnetic Compatibility Regulations 2016**
- **The Restriction of the Use of Certain Hazardous Substances in Electrical and Electronic Equipment Regulations 2012**

References to the relevant harmonised standards used or references to the other technical specifications in relation to which conformity is declared:

BS EN 676:2020 Including the requirements of Annex K.
Automatic forced draught burners for gaseous fuels.

Additional information can be downloaded at: www.bentone.com

Manufacturer: CTC AB
Näsvägen 8
SE-341 34 LJUNGBY
Sweden

Approved Body: TUV SÜD BABT Unlimited
Octagon House,
Concorde Way, Segensworth North,
Fareham, Hampshire,
PO 15 5RL, United Kingdom
Approved Body Number: 0168

Ljungby, 2024-01-01

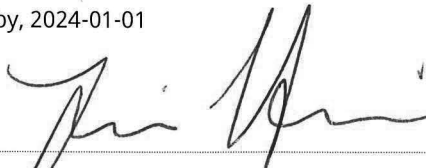

Joachim Hultqvist
Technical Manager
CTC AB



Ola Karlsson
Quality Manager
CTC AB



CTC AB Box 309 SE-341 26 Ljungby
info@bentone.se +46 372 88 000
www.bentone.se