



Providing sustainable energy solutions worldwide

Installation- and maintenance instruction

BG 300

LME21.550C2

MB-DLE 407



-sv

1. Manualer på övriga språk

2. [www.bentone.com\download](http://www.bentone.com/download) eller scanna QR-koden.

3. Skriv in brännarens artikelnummer som finns på din typskylt (se bild) och välj ditt språk.

Detaljerad ecodesign information kan laddas ner på:
www.bentone.com/ecodesign.

-fr

1. Manuels dans d'autres langues

2. [www.bentone.com\download](http://www.bentone.com/download) ou scannez le code QR.

3. Saisir le numéro d'article du brûleur sur votre plaque signalétique (consultez l'illustration) et sélectionnez la langue.

Des informations détaillées sur l'ecodesign peuvent être téléchargées à l'adresse:
www.bentone.com/ecodesign.



-en

1. Manuals in other languages

2. [www.bentone.com\download](http://www.bentone.com/download) or scan QR-code.

3. Enter the burner's article number on your data plate (see picture) and select language.

Detailed ecodesign information can be downloaded at:
www.bentone.com/ecodesign.

-de



1. Gebrauchsanweisungen in anderen Sprachen

2. [www.bentone.com\download](http://www.bentone.com/download) oder scannen Sie den QR-Code.

3. Geben Sie die Artikelnummer des Brenners auf Ihrem Typenschild ein, (siehe Bild) und wählen Sie die Sprache aus.

Detaillierte Informationen zum Ecodesign können unter www.bentone.com/ecodesign heruntergeladen werden.

3. exempel example Beispiel

352011030141	Serial no. 1234567	Man.Year 2019
Designation	BF 1 KS 76-24	
Type	BF 1	
Model	BF 1 KS 76-24	
Cap. Min-Max	LIGHT OIL 35-90KW 1,25-6,0 cSt 7-14bar	
Main supply	1-230V 1,0A 50Hz IP 20	
Motor supply		
MADE IN SWEDEN BY		

-da

1. Manualer på andre sprog

2. [www.bentone.com\download](http://www.bentone.com/download) eller scan QR-koden.

3. Indtast brænderens artikelnummer, der findes på typeskiltet (se billede), og vælg dit sprog.

Detaljerede oplysninger om ecodesign kan downloades på:
www.bentone.com/ecodesign.

Table of contents

1. General Information	4	7. Service	28
2. Technical Data	7	7.1 Servicing the combustion assembly	28
2.1 Dimensions	7	7.2 Servicing air dampers	29
2.2 Capacity range	8	7.3 Flame monitoring and ionisation current check	30
2.3 Gas categories, approved gases	8	8. Handing over of the installation	32
2.4 Working field	9	9. Fault location, functional troubles	32
2.5 Electric Specification EN 60335-2-102	9	10. Electric equipment	33
2.6 Description	10	10.1 Wiring diagram LME...	34
3. General instructions	11	10.2 Function LME...	35
3.1 General instructions	11	10.3 Control program when disruption;	36
3.2 Installation and maintenance instructions	11	11. Troubleshooting	38
3.3 Instructions	11	12. General instructions for gasburners	41
3.4 Inspection and maintenance	11		
3.5 Start up	11		
3.6 Commissioning of installation	11		
4. Installation	12		
4.1 Delivery check	12		
4.2 Preparations for installation	12		
4.3 Gas supply	12		
4.4 Electric connection	12		
4.5 Setting brake plate and air flow	12		
4.6 Inspection of gas nozzle before commissioning	13		
4.7 Gas nozzle	14		
5. Setting the burner	15		
5.1 Air adjustment	15		
5.2 Adjustment of brake plate	15		
5.3 Control of burner head	15		
5.4 Setting the air pressure switch	17		
5.5 Setting the min. gas pressure switch	18		
5.6 Skeleton diagram CPi	19		
6. MULTI-BLOC,	20		
6.1 Overview	20		
6.2 Mounting closed position indicator (CPi)	21		
6.3 Adjustment of governor	22		
6.4 Adjustment of start gas flow valve V3	22		
6.5 Flow adjustment main valve V2	22		
6.6 Skeleton diagrams	23		
6.7 Recommended excess air when using default setting	25		
6.8 Determining the gas quantity for the system	25		
6.9 Calculating the quantity of gas supplied	27		

1. General Information

This Installation and Maintenance manual:

- is to be regarded as part of the burner and must always be kept near the installation site.
- is intended for use by authorised personnel.
- must be read prior to installation.
- must be observed by all who work with the burner and associated system components.
- work with the burner may only be carried out by certified installers/ personnel.

Enertech AB is not liable for any typographical errors and reserves the right to make design changes without prior notice.

Safety instructions

- The burner may only be used for its intended purpose in accordance with the product's technical data.
- The burner may only be installed and operated by authorised personnel.
- The product is packaged to prevent damage from occurring during handling. Handle the product with care. Lifting equipment must be used to lift larger packages.
- The products must be transported/stored on a level surface in a dry environment, max. 80% relative humidity, no condensation. Temperature -20 to +60 °C.
- Check that the burner is compatible with the boiler's output range.
- All components must be installed without being bent, twisted or subjected to mechanical or thermal forces which can affect the components.
- The burner must be installed so that it complies with local regulations for fire safety, electrical safety, and fuel distribution.
- The gas outlet from the pressure regulator shall be configured in accordance with applicable regulations and lead to a safe area.
- Make sure when installing the equipment that there is enough space to service the burner.
- Permitted temperature during operation -10 to +60 °C. Max 80% relative humidity, no condensation.
- The installer must ensure that the room has adequate air supply.
- The room must comply with local regulations pertaining to its intended use.
- The installation site must be free of chemicals.
- Burner pipes, fan wheels and air dampers may contain sharp edges.
- The surface temperature of the burner's components can exceed 60 °C.
- Caution: The burner has moving parts, and there is risk of crushing injuries.



- The electrical installation must be professionally carried out in accordance with applicable high voltage regulations, as per Enertech's recommendations.
- Before servicing, shut off the fuel supply and turn off the power to the burner.
- Seal inspections must be performed during installation and servicing to prevent gas leakage.
- Care should be taken by the installer to ensure that no electrical cables or fuel lines are crushed or otherwise damaged during installation or servicing.
- If the boiler is equipped with an access hatch, this must be equipped with a hatch opening switch connected to the burner's safety system.
- When in operation, the burner's noise level can exceed 85 dBA. Use hearing protection.
- The burner must not be put into operation without proper safety and protection devices.
- A Class BE fire extinguisher is recommended.
- It is forbidden to alter the design or use accessories which have not been approved by Enertech in writing.
- Prior to operation, the following points must be checked:
 - fitting and installation work has been completed and approved
 - electrical installation has been correctly performed
 - flue gas ducts and combustion air ducts are not blocked
 - all actuators and control and safety devices are in working order and correctly set



Actions to take if you smell gas

Turn off the equipment and the boiler. Open windows and doors. Prevent open flames or sparking, e.g. do not turn lights on or off, do not use any electrical appliances, do not use mobile phones. Open windows and doors. Close the gas ball valve. Warn residents; do not use doorbells. Evacuate the building. Notify the installer or gas supplier once the building has been evacuated.

Burner servicing schedule

Servicing must be carried out once a year or after 3 000 hours of operation.

Burner	1 year	3 000 hrs
Inspection of electrical installation	1 year	3 000 hrs
Leakage check	1 year	3 000 hrs
Filter	1 year replacement at $\Delta p > 10$ mbar	3 000 hrs replacement at $\Delta p > 10$ mbar
Electrodes	Replacement/Cleaning 1 year	Replacement/Cleaning 3 000 hrs
Brake disc	Replacement/Cleaning 1 year	Replacement/Cleaning 3 000 hrs
Motor	1 year	3 000 hrs
Fan wheel	1 Year Replacement when cleaning needed/imbalance	3 000 hrs Replacement when cleaning needed/imbalance

Component replacement intervals

Control system	10 years	250 000 starts
Valve control system	10 years	250 000 starts
Pressure switch	10 years	250 000 starts
Ignition system with flame guard	10 years	250 000 starts
UV flame sensor	10 000 hrs	N/A
Gas pressure regulators	15 years	N/A
Gas valve without seal testing	10 years	250 000 starts
Gas valve with seal testing	Replacement upon fault detection	N/A
Gas pressure switch	10 years	250 000 starts
Safety blow-off system	10 years	N/A
Damper motor	N/A	500 000 starts
Contactors	10 years	500 000 starts



The burner and its components must be recycled according to applicable regulations.

Delivery check

- Make sure everything is delivered and the goods have not been damaged during transit.
- If something is wrong with a delivery, report it to the supplier.
- Transport damage must be reported to the shipping company.

2. Technical Data

Burners are intended for use at:

- Hotwater in intermittent operation.

2.1 Dimensions

- Gas connections 1"

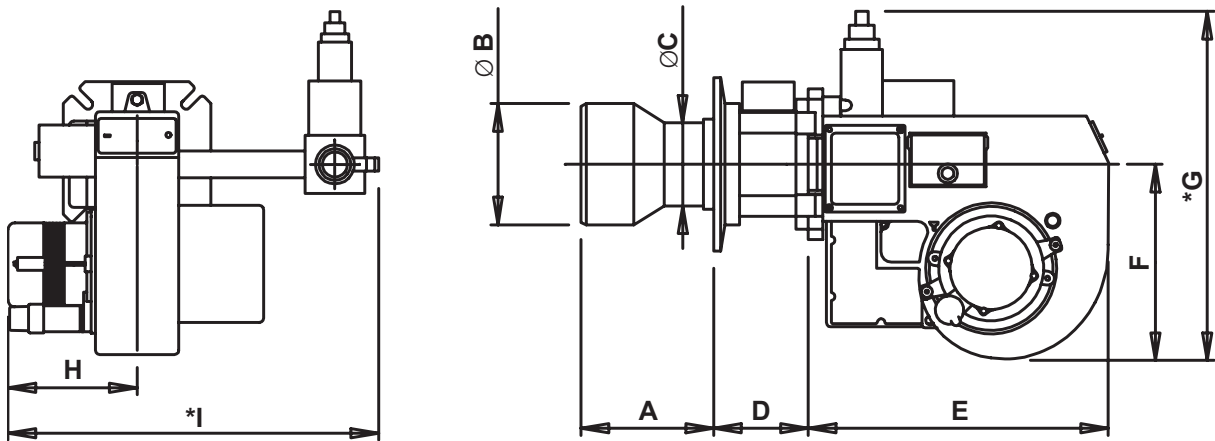

Type		Length of burner tube	Flange measure A
BG 300	Standard 1	145	125
	Standard 2	245	225

* Depending on which components that are used, dimensions may vary

	B	C	D	E	F	G	H	I	
BG 300	Ø 120	Ø108	100	372	220	*380	170	*460	**200

	J	K	L
BG 300	M10	Ø 175-240	Ø 120

* The above dimensions are max. measurements. Depending on the components used, the measurements may vary.

**Min recommended distance to floor.

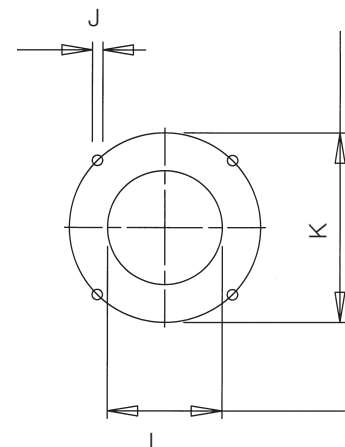

2.2 Capacity range

Capacity kW	Gas quantity at min. power Nm ³ /h ¹⁾	Gas quantity at max. power Nm ³ /h ¹⁾	Max. connection pressure mbar	Min connection pressure mbar
BG 300				
G20 50-200	5.2	21	360	See data plate
G25 50-170	6,1	20,7	360	
G30 65-200	2,0	6,1	360	
G31 50-200	2,0	8,1	360	

1) Lower heat value Hu at normal state 15°C and 1013.25 mbar EN676				
Grade of gas		kWh/Nm ³	MJ/Nm ³	kcal/Nm ³
Natural gas	G20	9.5	34.02	8126
Natural gas	G25	8.2	29.25	6986
Butane	G30	32.5	116.09	27728
Propane	G31	24.6	88.00	21019

Gas quantity and capacity vary according to grade of gas and connection pressure.

2.3 Gas categories, approved gases

Only dry gas is permitted for use.

Category	Country of destination	Supply pressure
II _{2R3R}	AT, BE, BG, CH, CY, CZ, DE, DK, EE, ES, FI, FR, GB, GR, HR, HU, IE, IS, IT, LT, LU, LV, MK, MT, NL, NO, PL, PT, RO, RS, SE, SI, SK, TR	20 mbar
II _{2H3B/P}	AT, CH, CY, DK, FI, LT, RO, SE, SK	20 mbar
II _{2H3P}	GB, IE	20 mbar
II _{2L3B/P}	NL, RO	20 mbar
II _{2E3B/P}	PL	20 mbar
I _{2E(R)B}	BE	20 mbar
I _{3P}	BE	20 mbar

160302-180-2

2.4 Working field

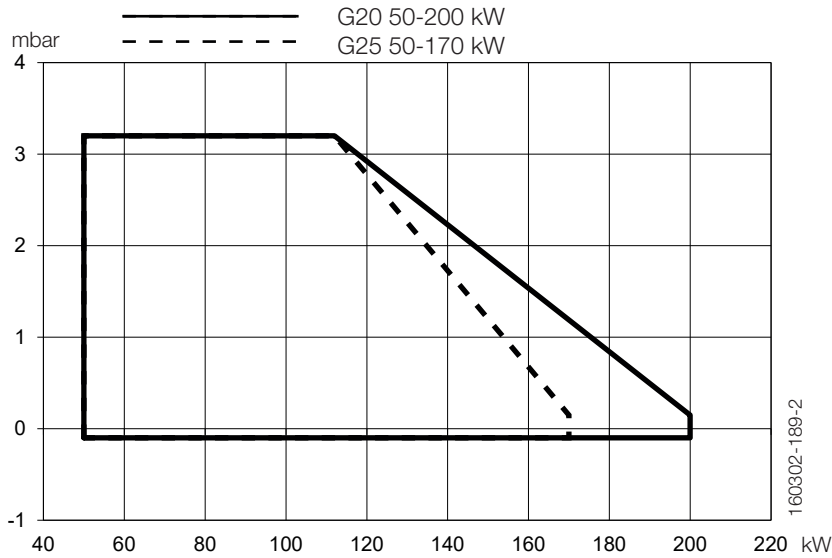

! Do not exceed working field.

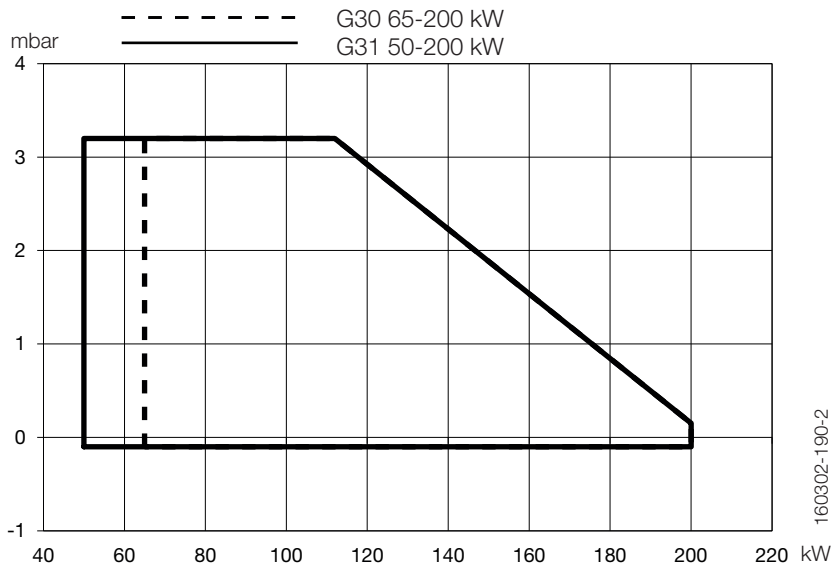

2.5 Electric Specification EN 60335-2-102

Burner correspond to IP20

Type	BG 300
Motor supply	180W 230V 1,3A 50Hz
The recommended main fuse motor	C10A
Main supply	230V 2,1A 50Hz
Sound	82 dBA ± 0,5 dBA

Max operating current, see data plate.

Measurements according to EN 3746: 2010

Alt.1 The sound level of the burner can be reduced by equipping the burner with silencer. Installation must be done so it does not prevent air supply to the burner.

Alt.2 The burner's noise level can be reduced by connecting the burner's air intake to the air duct that opens into an appropriate location. Installation must be done so it does not prevent air supply to the burner.

172 525 19-2 2021-04-22/3

2.6 Description

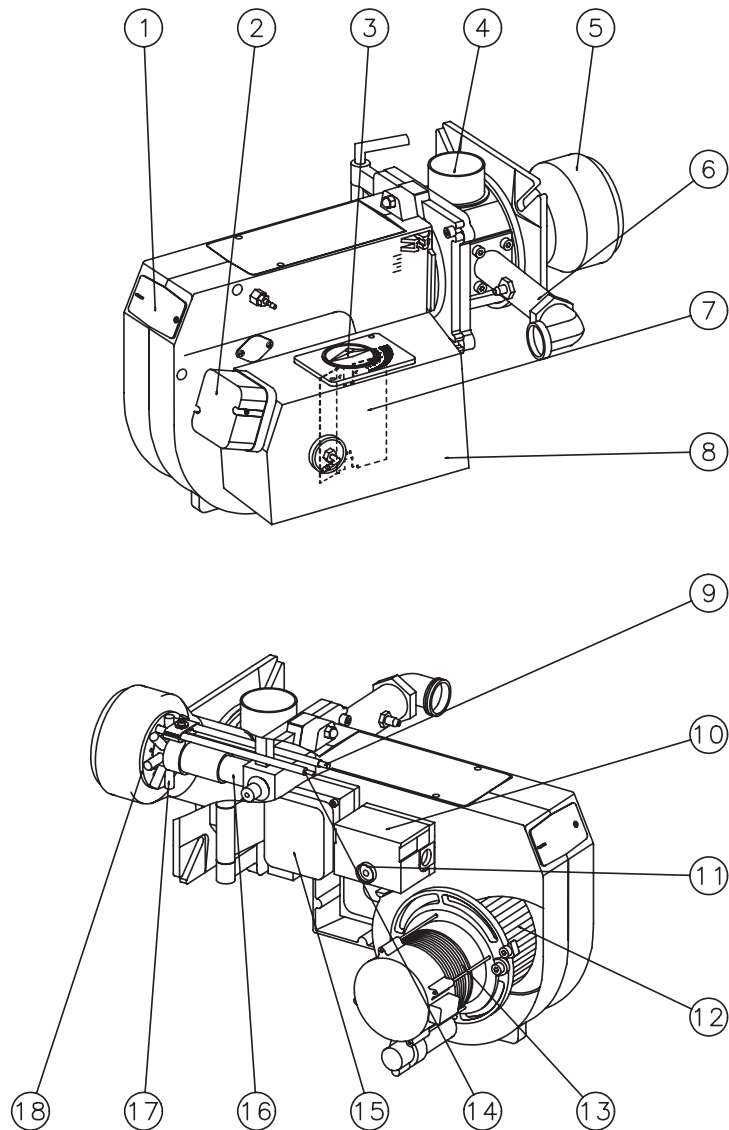

2.6.1 Components

- | | | |
|------------------------------|-----------------------|--------------------------|
| 1. Cover, inspection glass | 7. Air damper | 13. Motor |
| 2. Air pressure switch | 8. Air intake | 14. Ionization electrode |
| 3. Air adjustment | 9. Ignition electrode | 15. Transformer |
| 4. Inner assembly adjustment | 10. Control box | 16. Inner assembly |
| 5. Blast tube | 11. Reset button | 17. Nozzle |
| 6. Connecting pipe | 12. Fan wheel | 18. Brake plate |

3. General instructions

3.1 General instructions

The installation of the gas burner must be carried out in accordance with current regulations and standards. The installers of gas burners should therefore be acquainted with all regulations and ensure that the installation complies with the requirements. The installation, mounting and adjustment should be made with the greatest care and only the correct gas should be used.

3.2 Installation and maintenance instructions

The maintenance instructions supplied with the burner must be kept at an easily accessible location in the boiler room.

3.3 Instructions

The user should be thoroughly instructed in the function of the gas burner and the whole installation. The supplier must instruct the user.

3.4 Inspection and maintenance

The unit must be serviced and maintained at the interval specified in the service schedule. If the burner is in a dirty environment, service should be done at more frequent intervals than specified.

3.5 Start up

After the burner has been fitted to the boiler and the electric connection, the leakage control, the venting and the electric function test have been carried out, the burner will be ready for start-up.

However, study the sections dealing with adjustments of multi-bloc, combustion air and combustion head. Open the ball valve and switch on the main switch. If the burner starts the actual adjustment can be made.

3.6 Commissioning of installation

Control of the combustion. The combustion quality is checked by means of a flue gas analysis device. Adjust the burner to appr. 20% excess air in accordance with the table. Check the flue gas temperature. Calculate the efficiency. Check also the actual gas volume on the gas meter so that the correct input is achieved.

4. Installation

4.1 Delivery check

Check that all has been delivered and that the goods have not been damaged during transport. If that is not the case, please notify the delivery company. Transport damages should be reported to the forwarding agency.

4.2 Preparations for installation

Check that the measurements and capacity range of the burner are compatible with the boiler. The power ratings on the type plate refer to the min. and max. power of the burner.

4.3 Gas supply

For good operating safety, it is important that the gas supply system is installed correctly.

Consider the following:

1. Check that the burner is approved for the gas quality of the installation. If not, please contact the supplier.
2. Check that the gas components of the burner are approved for indicated gas pressure.
3. The gas supply system should be installed in accordance with current standards.
4. Pipe lines should be run so that service on boiler and burner is facilitated.
5. Pipe lines should be run so that eventual contaminants cannot come into contact with the gas components.
6. Gas discharge system must be installed prior to local regulations.

4.4 Electric connection

Before starting the electric installation, the main switch must be turned off. If the boiler has a 7-pole and a 4-pole Eurostecker connector, these usually fit directly to the burner. If not, use the connectors included, (see connection under Electric equipment).

4.5 Setting brake plate and air flow

Before the placing into service, the burner should be initially set according to diagram, (see Basic settings). Note that it is only a basic setting which should be adjusted once the burner has been started.



If an electric connection other than the one recommended by Enertech is used, a risk of damage and injury can arise.

4.6 Inspection of gas nozzle before commissioning

General rules

Care should be taken by the installer to ensure that no electrical cables or fuel/gas pipes are trapped or damaged during installation or service/maintenance.

Gas nozzle

Check that the ignition and ionisation electrodes are correctly set. In the figure (see the gas nozzle chapter), the dimensions are specified for adjustment of the ignition and ionisation electrodes.

Gas quality

Ensure that the burner head is meant for the gas quality to be used (see chapter gas nozzle).

De-aerating

De-aerating of the gas line is conducted, for example, by unscrewing the screw on the measuring nipple for the connection pressure. Connect a plastic hose and release the gas in a safe place. Once de-aerating is completed, be sure to refit the screw on the measuring nipple.

Leakage control

When making a leakage control of the gas supply system the solenoid valve should be closed. Connect a pressure gauge to the test nipple Pa, see fig. The test pressure in the system should be 1,5x max. inlet pressure or min. 150 mbar. If any leakage, locate the source by means of soapy water or a leak location spray. After tightening repeat the test.

Electric function test:

Ensure that phase and neutral are not reversed. The gas shut-off cock should be closed. To prevent the gas pressure switch from locking out it should be linked temporarily.

After the main switch has been switched on and the thermostats have been adjusted the pre-purging period begins (30-35sec.). At the end of this period the pre-ignition period starts (0,5-2,5 sec. dependent on the design of the gas control). The gas valve is energized and opens and flame is established. At the end of the safety time (2-3 sec.) the gas control locks out. The solenoid valve and the motor will be "dead". Remove the link from the gas pressure switch after the test is finished.

! If the burner is directly connected, ensure that all components on the burner are without power.

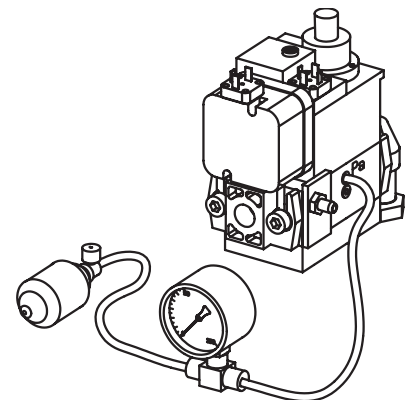

4.7 Gas nozzle

Propane

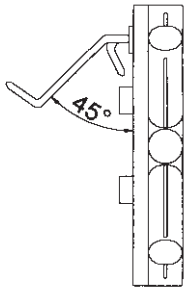

Natural gas

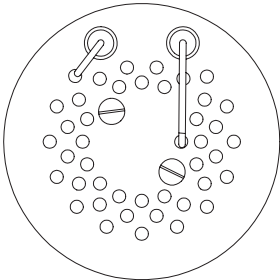
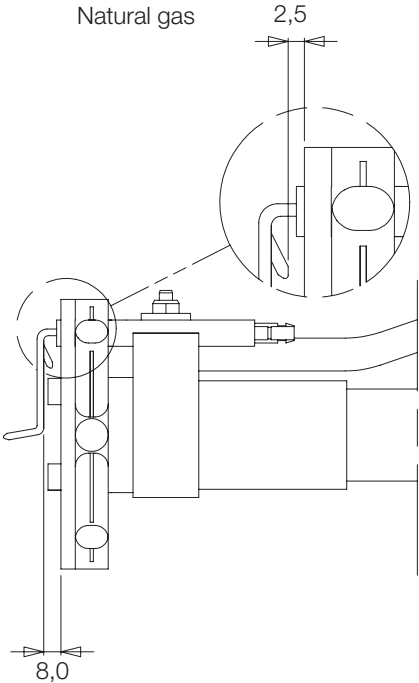

Biogas (UV detector)

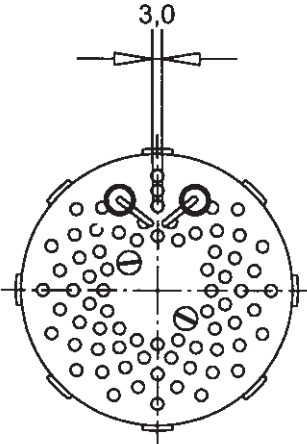
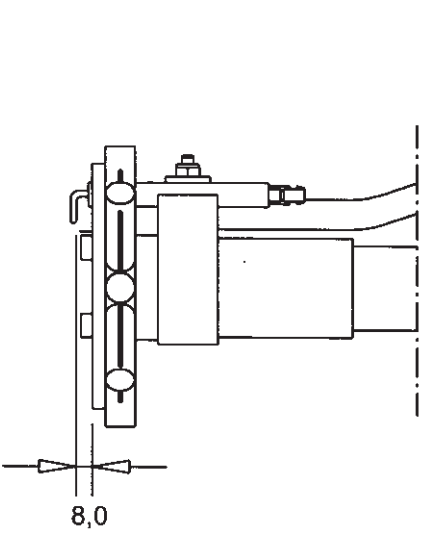

5. Setting the burner

5.1 Air adjustment

Loosen the stop screw and turn the knob along the scale to the desired position and tighten the screw. Check the air adjustment by making a flue gas analysis.

Air adjustment

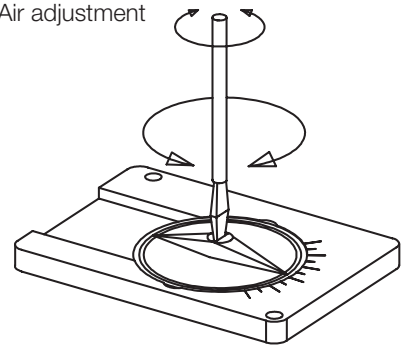

5.2 Adjustment of brake plate

-Loosen the screw on the adjustment device.

-To reduce the opening: turn the knob to the left.

-To increase the opening: turn the knob to the right.

The adjustment of the position of the brake plate affects the air flow. It is therefore always necessary to make a fine adjustment of the air by means of the adjustment device of the burner.

Adjustment of inner assembly

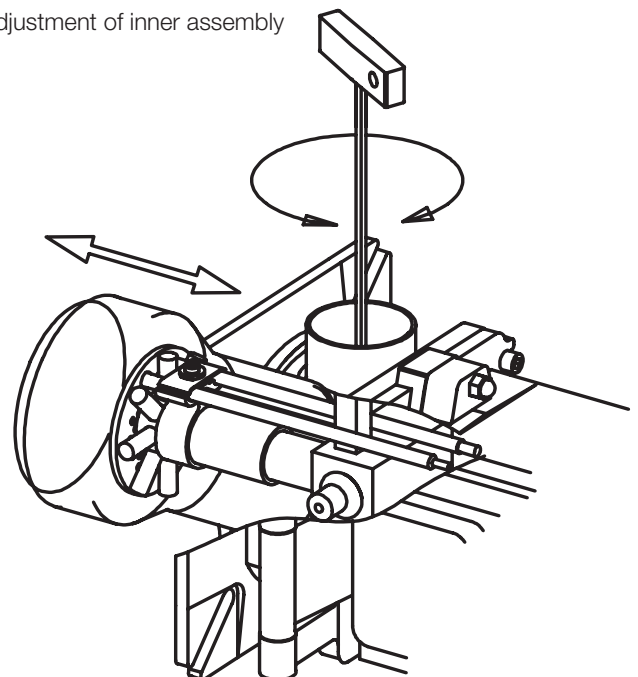

5.3 Control of burner head

To check the burner head, brake plate and electrodes proceed as follows:

Loosen the nuts a. Swing out the burner. Remove the screw b and the knob for adjustment of burner head. Loosen the screw c so much so that the inner assembly can be pulled out.

Control of burner head

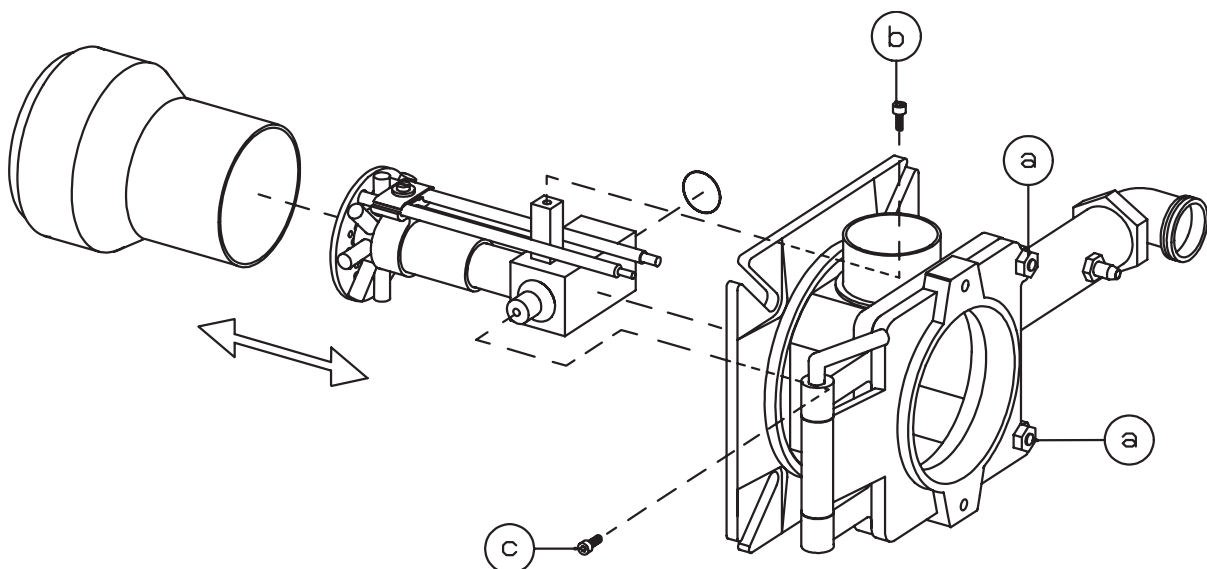

172 515 09

General instructions

The installation of the gas burner must be carried out in accordance with current regulations and standards. The installers of gas burners should therefore be acquainted with all regulations and ensure that the installation complies with the requirements. The installation, mounting and adjustment should be made with the greatest care and only the correct gas should be used.

User manual

The installation and maintenance instructions supplied with the burner must be kept at an easily accessible location in the boiler room.

Instructions

The user should be thoroughly instructed in the function of the gas burner and the whole installation. The supplier must instruct the user.

Inspection and maintenance

Inspection as needed, preferably daily. Maintenance per service schedule.

Start up

After the burner has been fitted to the boiler and the electric connection, the leakage control, the venting and the electric function test have been carried out, the burner will be ready for start-up.

However, study the sections dealing with adjustments of multi-bloc, combustion air and combustion head.

Open the ball valve and switch on the main switch. If the burner starts the actual adjustment can be made.

Adjustment of burner head

The burner is equipped with an adjustment device changing the position of the brake plate in the burner head. This is used to adjust the correct pressure drop over the combustion device in order to obtain a good pulsation free combustion.

Which position to use depends on input and overpressure in the boiler.

A general rule is that the lower capacity the smaller the opening between brake plate and combustion device.

Commissioning of installation

Control of the combustion. The combustion quality is checked by means of a flue gas analysis device. Adjust the burner to appr. 20% excess air in accordance with the table. Check the flue gas temperature. Calculate the efficiency. Check also the actual gas volume on the gas meter so that the correct input is achieved

Service

Service should only be carried out by qualified personnel. Replacement parts should be of the same make and approved by the same authorities as the original. If the burner is converted to fire another gas quality it must be re-commissioned. If town gas is to be fired the combustion head must be converted and the gas train adjusted to suit (e.g.a larger gas armature or a different spring in the governor may be required).

Gas quality	CO ₂ % lambda 1,2	O ₂ %	max. CO ₂ %
Natural gas	10,0	4±1	11,9
LPG	11,5	4±1	13,9

5.4 Setting the air pressure switch

The air pressure switch should block the burner if the air quantity supplied for combustion is insufficient. The air pressure switch must be set so that, if there is a defective air supply at the burner's max. or min. capacity, it reacts before the monitored pressure falls so much that it results in poor combustion.

Inställningsområde ca:

LGW 10	1-10	mbar
LGW 50	2,5-50	mbar

Setting for air pressure switch

1. Remove the protective cover, screw (Y).

! Be careful when adjusting the air pressure switch; it contains a live component.

2. Start the burner.
3. Carefully turn the scale on the air pressure switch clockwise until the air pressure switch stops the burner.
4. Try to find the pressure at which the burner stops for both the minimum and maximum input power by turning the scale. Make a note of the values and then set the air pressure switch on the basis of the highest pressure noted at which the burner stopped.
5. The air pressure switch should be set to a pressure approx. 10–15% lower than the highest noted pressure at which the burner stopped.
6. After setting the air pressure switch, perform repeated starts and run through the burner's set output range several times. This is to ensure the reliable function of the burner. If breakdowns or interruptions occur, the air pressure switch is probably set to a too narrow position.
7. Fit the protective cover, screw (Y).



172 515 09

5.5 Setting the min. gas pressure switch

The min. gas pressure switch should react to a burner connection pressure that is too low and in such cases prevent the burner from starting. If the connection pressure to the burner is too low during operation, the min. gas pressure switch should stop the burner. The burner can start again once the connection pressure has risen above the pressure set for the min. gas pressure switch.

Setting for min. gas pressure switch

1. Remove the protective cover, screw (Y).
2. Open the pressure outlet (X) and connect a manometer to measure the connection pressure.
3. Start the burner.
4. Measure and make a note of the connection pressure to the burner during normal operation at the highest input power.
5. Based on the desired connection pressure set, determine the connection pressure at which the gas pressure switch should stop the burner. Set the connection pressure at which the burner is stopped at a level where the burner is stopped before poor combustion occurs.
6. Set the min. gas pressure switch to this value by turning the scale.
7. Check the setting by carefully closing the ball valve while measuring the connection pressure.
8. When the min. gas pressure switch stops the burner, the value measured should then approximately correspond to the setting on the min. gas pressure switch. The tolerance on the scale for the min. gas pressure switch is approx. $\pm 15\%$.
9. Open the ball valve.
10. Remove the pressure gauge and close the pressure outlet (X).



Check the gas tightness.

11. Fit the protective cover, screw (Y).



172 515 09

5.6 Skeleton diagram CPI

1. Ball valve
2. Filter
3. Governor
4. Pressure gauge with shut-off cock
- 5a. Gas pressure switch, mini
- 5b. Gas pressure switch, maxi
- 6a. Main valve
- 6b. Safety valve
7. ¹⁾ Valve proving system
9. Air pressure switch
10. Electrical connection
11. Solenoid V3

Pos. 5b, 7: Components not required according to EN 676.

¹⁾ Required over 1200 kW according to EN 676.

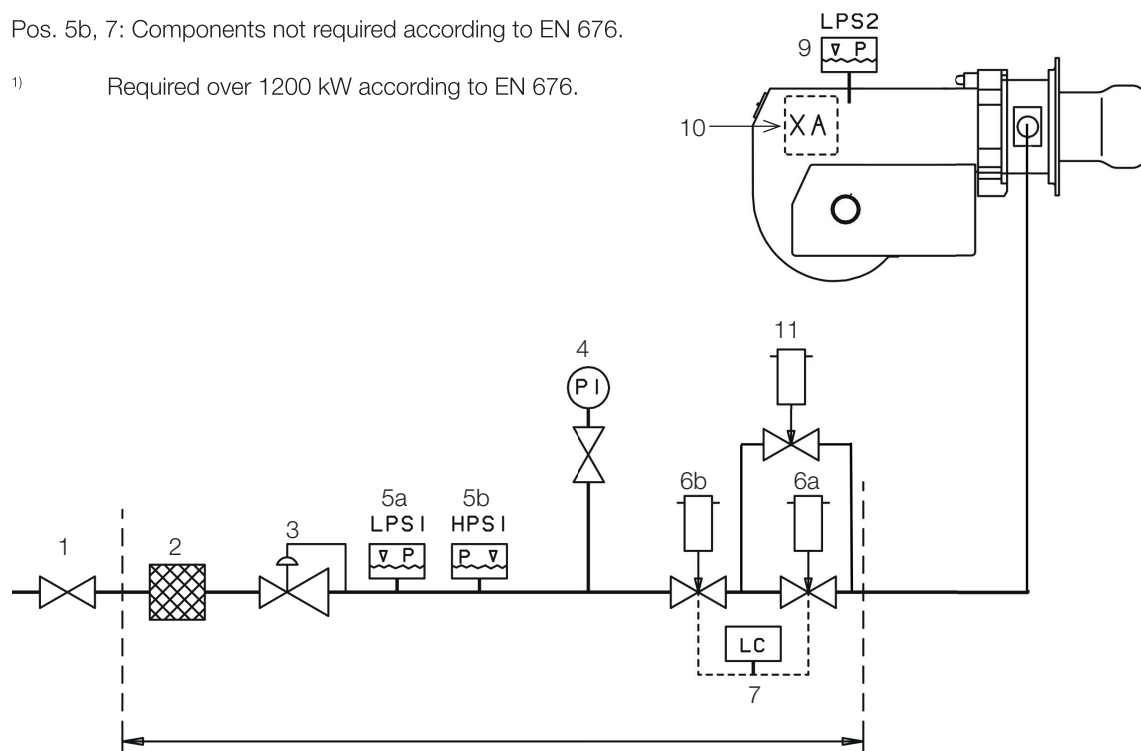

6. MULTI-BLOC,

MB-DLE 407 B07 S22 GW150A5

6.1 Overview

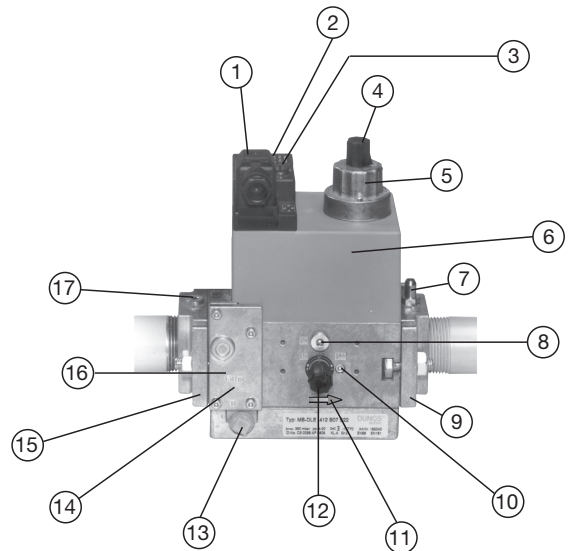
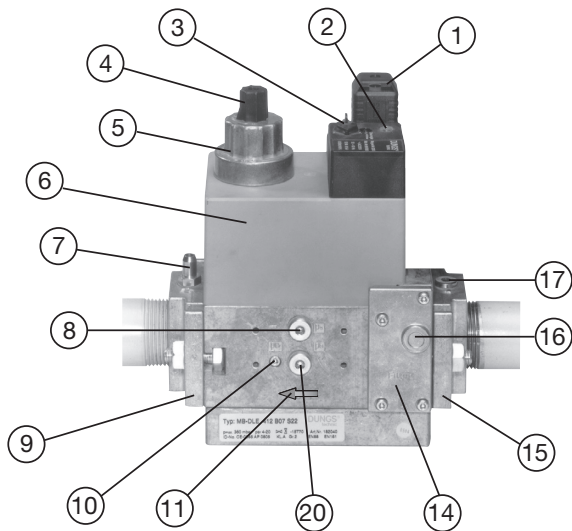

Max. inlet pressure: 360 mbar. Adjustable governor pressure:

405 - 412 S5x = 4 - 50 mbar

415 - 420 S2x = 4 - 20 mbar

415 - 420 S5x = 20 - 50 mbar

- | | |
|--|---|
| <ol style="list-style-type: none"> 1. Electrical connection for V1, V2, V3 (DIN EN 175 301-803 connector) (option) 2. Operation display V1, V2 (optional) 3. Gouverneur adjustment 4. Setting cap hydraulic brake 5. Hydraulic brake or setting plate gas flow 6. Solenoid 7. Test point connection G 1/8 possible 8. Test point connection G 1/8 downstream of valve1, possible on both sides 9. Outlet flange 10. Test point connection M4 downstream of valve 2 11. Gas flow direction | <ol style="list-style-type: none"> 12. Bypass throttle, V3 Pilot flame 13. Vent nozzle, regulator 14. Filter (below cover) 15. Inlet flange 16. Test point connection G 1/8 upstream of filter, possible on both sides. 17. Test point connection G 1/8 possible 18. Pressure switch (option) 19. Electrical connection for pressure switch (DIN EN 175 301-803 connector) (option) 20. Test point connection G 1/8 upstream of V1, possible on both sides |
|--|---|

6.2 Mounting closed position indicator (CPI)

1. Interrupt gas supply.
2. Remove G 1/8 seal plug and O ring from valve bottom.
3. Screw closed position indicator with new O ring (9,5 x 1.6).
4. Tighten using open-ended spanner WAF 12.
5. Electrical connection
Remove cover A.
Electrical connection to screw terminals 1,2,3.
6. Perform leakage and function test.
7. Set switching point
Remove cover B if there is no contact from terminal 1 to terminal 3 when valve is closed.

Rotate setting screw C to " + " until switching point is reached.

Then rotate the setting screw by another scale division.

Check function by activating the valve.

8. Re-set switching point Turn setting screw C back in arrow direction " - " to the stop; proceed as described in 7.

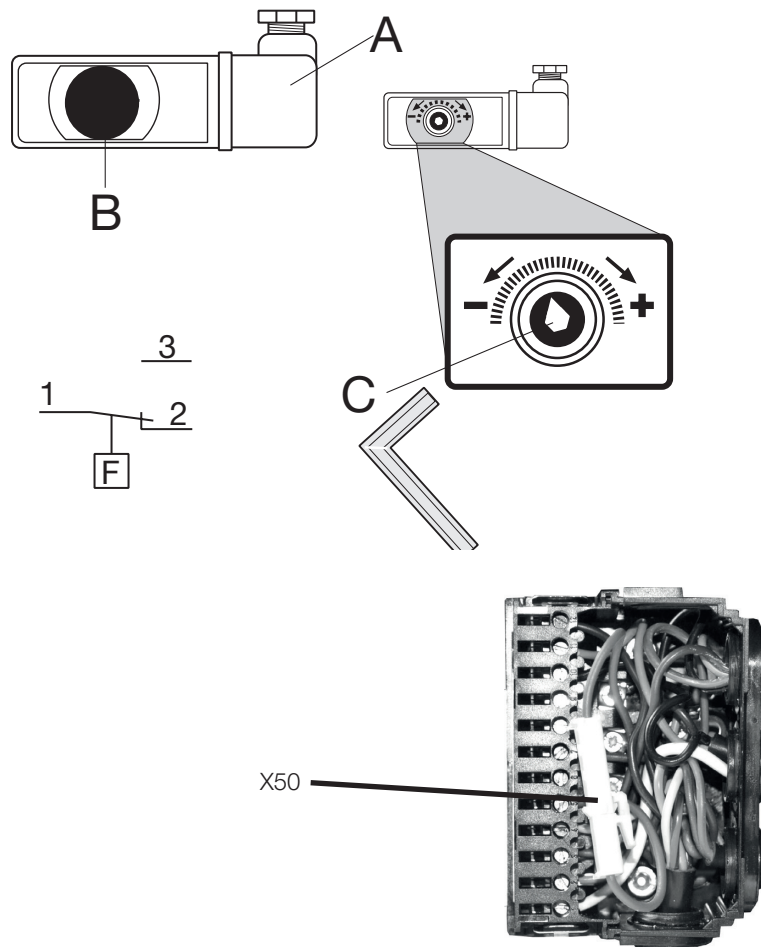

6.3 Adjustment of governor

Adjust outlet pressure from governor by means of a screw. Min. and max. outlet pressures corresponds to appr. 60 turns of the spring. It is not possible to change pressure springs in order to change the outlet pressure.

Turn to the right = the outlet pressure is increased

Turn to the left = the outlet pressure is reduced

6.4 Adjustment of start gas flow valve V3

Unplug X50 to disconnect V2 to make it possible to adjust start gas flow. Remove protection cap c.

Turn the adjustment screw e to the desired start gas flow.

Turn to the right = the start gas flow is reduced

Turn to the left = the start gas flow is increased

Adjust start gas flow to desired value. Connect contact X50

6.5 Flow adjustment main valve V2

For adjustment of main gas flow V2

Loosen the fixing screw a. Turn the hydraulic device b:

to the right = the gas flow is reduced

to the left = the gas flow is increased

Do not forget to tighten the fixing screw again.

The flow adjustment can also be made by means of the governor. Adjust the outlet pressure to a value giving the desired gas flow on the fully open valve.

At small capacities (gas flows) it is also necessary to adjust as above.

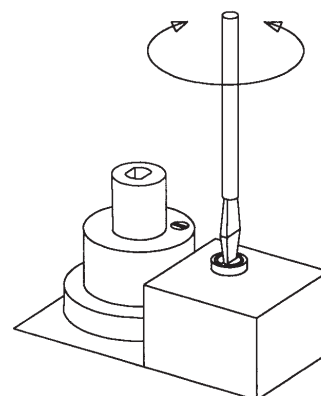

Adjustment of governor

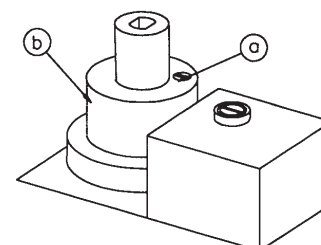
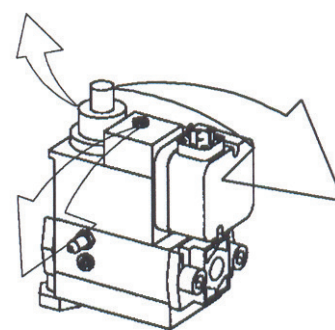

Flow adjustment

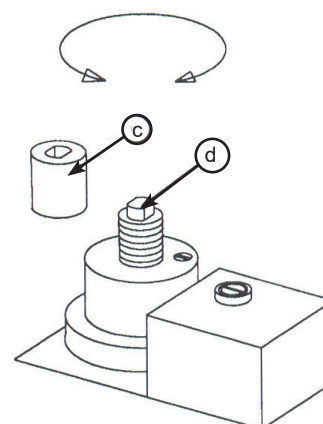

Adjustment of V2 damper

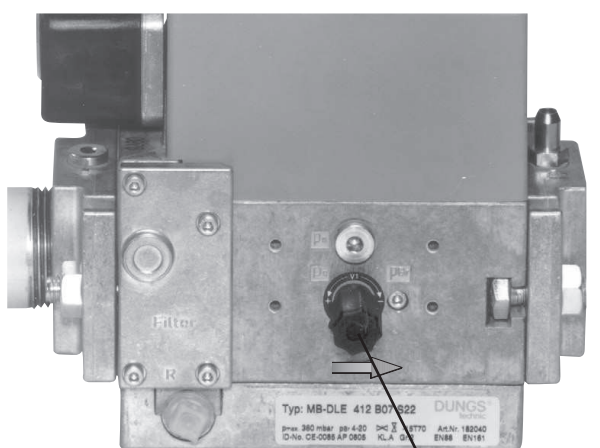

C
e:under cap

6.6 Skeleton diagrams

6.6.1 Multi-bloc MBD-LE.....B07

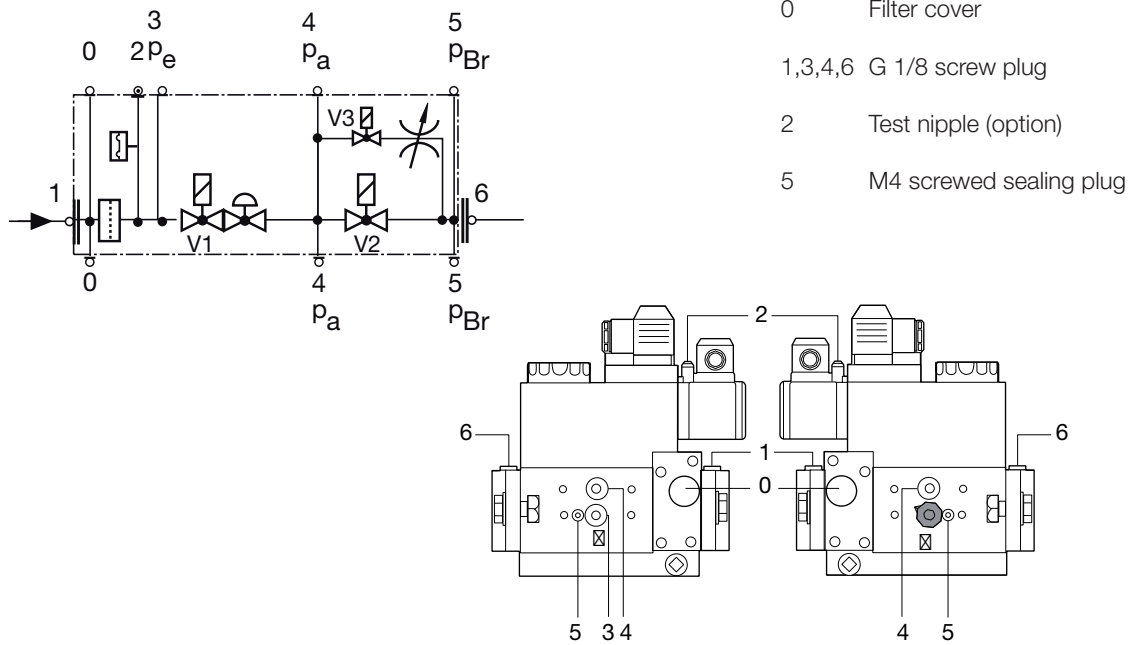

6.6.2 Electrical connection MBD-LE.....B07

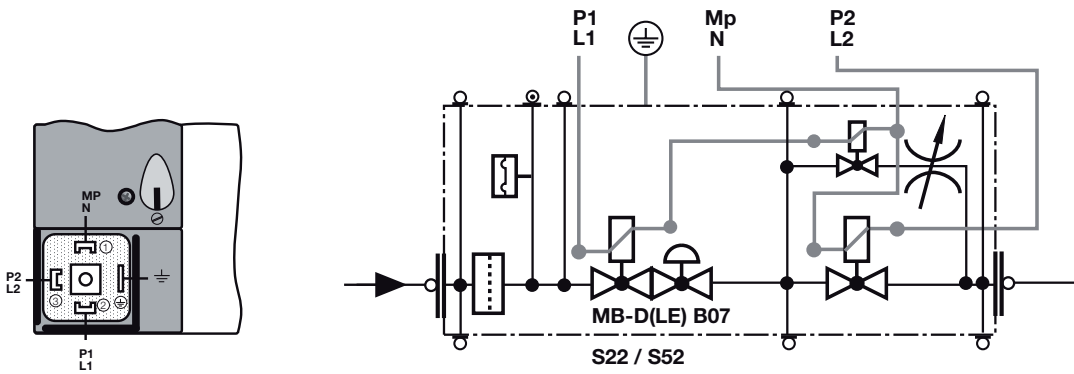

MB-DLE.....B07

6.6.3 Functional description of gas flow

1. When the valves V1 and V2 are closed, chamber A is under inlet pressure.
2. A hole D in the filter housing connects min. pressure switch with chamber A. If the inlet pressure applied to the pressure switch exceeds the incoming reference value, it switches through to the automatic burner control.
3. After release by the automatic burner control, valves V1 and V3 open.
The gas flows through chambers A, B and via bypass valve V3 in C of the GasMultiBloc. The ignition gas volume is adjusted by using the bypass restrictor. The pressure regulator controls the pressure upstream of valves V2 and V3.
4. When valve V2 is released, the gas flows directly into chamber C, the bypass valve V3 remains open.

6.6.4 Operating method of valve-regulator combination on valve V1

A regulator, compensating for residual pressure is integrated in valve V1 (pressure regulating part).

Armature 7 is not connected to the valve plate unit 3. When it opens, armature 7 pretensions compression spring (V1) 5 and releases the valve plate unit.

When the valve closes, the armature acts directly on the valve plate unit.

The output pressure upstream of valve V2 is defined by pretensioning the regulating spring 8 (tension spring) via setting screw 17. The output pressure acts via opening E on the working diaphragm 26 of the regulator. In regulated state, setting spring inlet pressure and pressure of working diaphragm are in force equilibrium. The compensating diaphragm ensures the fast closing function of valve V1 and a high regulating quality.

6.6.5 Operating method of bypass valve V3

The bypass valve V3 opens at the same time as valve V1. Ignition gas flow is set by using bypass restrictor 21.

6.6.6 Operating method of valve V2

Armature 14 of valve V2 is connected to valve plate unit 12. When it opens, armature 14 pretensions compression spring 13. The maximum valve opening can be set by limiting the armature stroke by means of the main volume restrictor 18.

Min. opening (residual stroke) of valve (0.5 to 1.0 mm)

The main volume restrictor is set by rotating the adjusting plate or the hydraulic brake. The fast and/or slow opening characteristic is influenced by setting fast stroke 19 at the hydraulic brake under the cover.

6.6.7 Closing function

When the supply voltage to the main valve solenoid coils is interrupted, valves V1, V3 and V2 are closed within < 1 s by the compression springs.

6.7 Recommended excess air when using default setting

Grade of gas	Excess air flue gases		Max. % CO ₂
	% O ₂	% CO ₂ Lambda 1.2	
Natural gas	3-5	≈10	11.9
Propane	3-5	≈11.5	13.9
Butane	3-5	≈11,5	14,1
Biogas	3-5		

6.8 Determining the gas quantity for the system

The heat values indicated are normal values; the heat value varies according to the origin of the gas. For more exact information on values, contact the gas distributor.

Lower heat value Hu at normal state 15°C and 1013.25 mbar EN676

Grade of gas		kWh/Nm ³	MJ/Nm ³	kcal/Nm ³
Natural gas	G20	9.5	34.02	8126
Natural gas	G25	8.2	29.25	6986
Butane	G30	32.5	116.09	27728
Propane	G31	24.6	88.00	21019
Biogas		6,0	21,60	5159

6.8.1 Example of how to calculate the gas quantity (natural gas G20):

$V_0 =$	Desired quantity of gas	[Nm ³ /h]
$Q =$	Boiler output	[kW]
$H_u =$	Gas heat value	[kWh/Nm ³] or [MJ/Nm ³] or [kcal/Nm ³]
$\eta =$	Boiler efficiency	[%]

Calculation example:

$$Q = 160 \text{ kW}$$

$$H_u = \text{Example A: } 34020 \text{ MJ/Nm}^3$$

$$\text{Example B: } 9.5 \text{ kWh/Nm}^3$$

$$\text{Example C: } 8126 \text{ kcal/Nm}^3$$

$$\eta = 90\%$$

$$V_{0A} = \frac{Q \cdot 3600}{H_u \cdot \eta} = \frac{160 \cdot 3600}{34020 \cdot 0.90} \approx 18.8 \text{ Nm}^3/\text{h}$$

$$V_{0B} = \frac{Q}{H_u \cdot \eta} \approx \frac{160}{9.5 \cdot 0.90} \approx 19 \text{ Nm}^3/\text{h}$$

$$V_{0C} = \frac{Q}{H_u \cdot 0.00116 \cdot \eta} = \frac{160}{8126 \cdot 0.00116 \cdot 0.90} \approx 19 \text{ Nm}^3/\text{h}$$

If the barometer reading (altitude), pressure and temperature of the gas deviate significantly from normal values, this must be taken into account as follows:

$T =$	Temperature of gas at the gas meter	[°C]
$B =$	Barometer reading	[mbar]
$P =$	Pressure of gas at the gas meter	[mbar]
$f =$	Factor calculated for multiplication with flow in Nm ³ /h to arrive at actual flow in m ³ /h.	
$V =$	Actual flow	[m ³ /h]
$f =$	$\frac{273}{273+T} \cdot \frac{B+P}{1013.25}$	

Calculation example:

$$T = 15^{\circ}\text{C}$$

$$B = 945 \text{ mbar}$$

$$P = 15 \text{ mbar}$$

$$f = \frac{273}{273+15} \cdot \frac{945+15}{1013.25} \approx 0.90 \text{ Nm}^3/\text{h}$$

This means that the quantity of gas read from the gas meter should actually be read off as 1.11 . the calculated flow in a normal state.

$$\begin{aligned} V &= V_0 \cdot f \\ V_A &= V_{0A} \cdot f = 18.8 \cdot 0.90 \approx 17 \text{ m}^3/\text{h} \\ V_B &= V_{0B} \cdot f = 19 \cdot 0.90 \approx 17 \text{ m}^3/\text{h} \\ V_C &= V_{0C} \cdot f = 19 \cdot 0.90 \approx 17 \text{ m}^3/\text{h} \end{aligned}$$

6.9 Calculating the quantity of gas supplied

The quantity of gas supplied can be calculated if the system is equipped with a gas flow meter of some type. The procedure here is usually to measure how long it takes for the burner to consume a certain quantity of gas.

To measure:

t = Time for a certain quantity of gas consumed by the burner. [h]

M = Quantity of gas consumed. [m³]

V = Actual gas flow [m³/h]

$$V = \frac{M}{t} \text{ [m}^3/\text{h]}$$

Calculation example:

$$t = 1 \text{ min } 10 \text{ s}$$

$$M = 330 \text{ dm}^3 \text{ (litre)}$$

$$M = \frac{330}{1000} = 0.33 \text{ m}^3$$

$$t = \frac{1}{60} + \frac{10}{3600} = 0.0194 \text{ h}$$

$$V = \frac{M}{t} = \frac{0.33}{0.0194} \approx 17 \text{ m}^3/\text{h}$$

7. Service

Whoever carries out service and maintenance on the burner must be authorised to do so. If components need to be replaced, the replacements must be of the same make and type and be approved by the authorities. If the burner is to be used for a different grade of gas, a new adjustment must be carried out. If town gas is to be used, it is also necessary to convert the combustion assembly; in some cases the multi-block or valves and gas train may also need to be changed to a larger type.

7.1 Servicing the combustion assembly

Removal and installation

1. Switch off the main power supply and disconnect the Euro plugs from the burner.



If the burner is directly connected, ensure that all components on the burner are without power.

2. Remove the screws (A), turn off the burner. Remove the ignition and ionisation cables
3. Check the combustion device's position. Remove the screw (B) to remove the adjustment device.
4. Remove the screw (C), remove the combustion device.
5. Check and clean the brake plate and gas inlet. If necessary, replace the worn parts.
6. Check the ignition electrode (see chapter Gas nozzle). Replace if necessary.
7. Check the ionisation electrode (see chapter Gas nozzle). Replace if necessary.
8. Fit the combustion assembly in reverse order.
9. Press the burner together and lock using the nuts (B).
10. Fit the Euro plugs and turn on the main power supply.
11. Check/adjust the combustion.

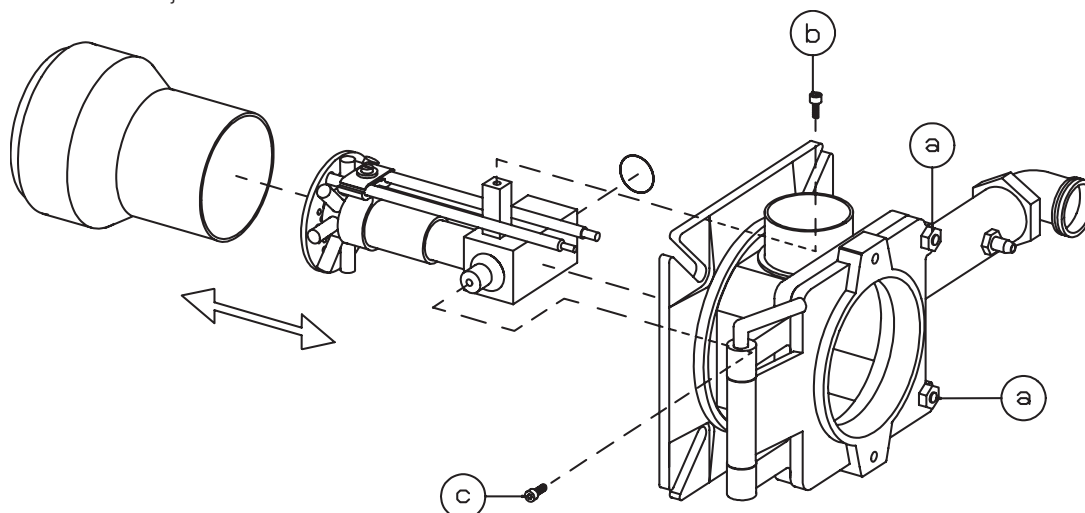

172 615 01 2018-01-02

7.2 Servicing air dampers

Removal and installation

1. Switch off the main power supply and disconnect the Euro plugs from the burner.



If the burner is directly connected, ensure that all components on the burner are without power.

2. Loosen the nuts (B) and pull the burner body out of the guides.
3. Remove the screws (d) holding the damper plate and screw (e) that secures the damper.
4. Turn the damper and then lift up the damper and damper plate.
5. Clean the air damper and intake. Lubricate the damper shaft, if so equipped.
6. Refit the damper and damper plate.
7. Adjust the damper before tightening the screws (d).
8. Install the intake grille for the air intake.
9. Check/adjust the combustion.

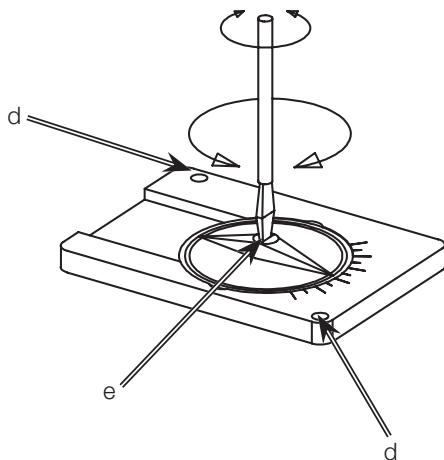

7.3 Flame monitoring and ionisation current check

The standard version of the burner is monitored according to the ionisation principle. The ionisation current should be checked on initial start-up and at each service visit.

Ionisation current is measured using a micro ammeter (μA) connected in series with the ionisation electrode and gas burner control. Connect the μ ammeter according to the diagram. The minimum required ionisation current is shown in the table. In practice, this current must be significantly higher, preferably more than $10 \mu\text{A}$. Connection of the μA instrument is made easier by the fact that all gas burners are equipped with a divisible ionisation cable.

The reason for low ionisation current can be leakage current, poor connection to earth, fouling or incorrectly positioned ionisation electrode in the combustion head. Occasionally, an incorrect gas/air mix may result in poor ionisation current.

Technical data

For continuous operation!

Idle voltage at ION-terminals	AC 115-230V
 Protect the ionisation electrode from electric shock!	
Short-circuit current	Max. AC 100-300 mA
Min. current for flame detection	Min. DC $1.5 \mu\text{A}$
Required current to ensure detection	Min. DC $3 \mu\text{A}$
Possible detection current	Max. DC $20 \mu\text{A}$
Operational indicator lamp flashes green	$<5 \mu\text{A DC}$
Operational indicator lamp shines green	$>5 \mu\text{A DC}$

7.3.1 Flame monitoring ionisation

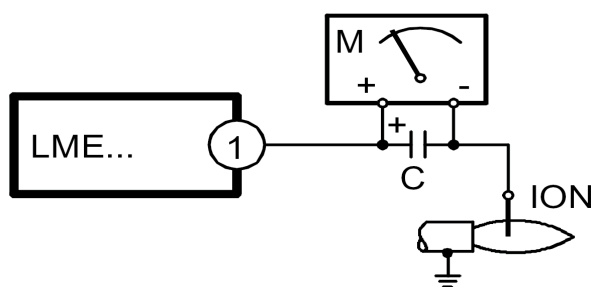

7.3.2 UV –detector (QRC)

Should not be exposed to temperatures higher than 60 °C. The current passing through the UV-detector, when it is lighted, should be at least 70 µA. The current can be measured with a moving coil instrument. A check is necessary only if a malfunction is suspected.

7.3.3 Flame monitoring UV-detector (QRC)

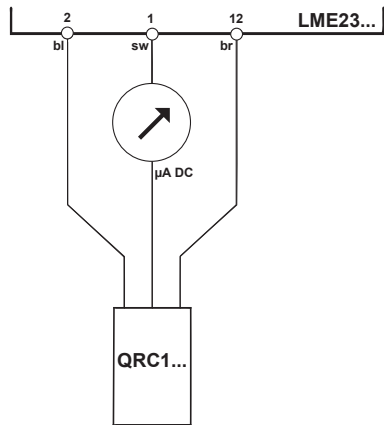

Technical data

For continuous operation!

Idle voltage at ION-terminals	AC 115-230V
 Protect the ionisation electrode from electric shock!	
Short-circuit current	Max. AC 100-300 mA
Max. current for flame detection	Max. DC 5.5 µA
Required current to ensure detection	Min. DC 40 µA
Possible detection current	Max. DC 60 µA
Operational indicator lamp flashes green	<45 µA DC
Operational indicator lamp shines green	>45 µA DC

8. Handing over of the installation

- Make repeated start attempts to ensure that the adjustments function.
- Close the ball valve during operation to check that the gas switch switches off at the set value.
- Remove the hose for the air pressure switch to check that the burner locks out.
- Check that all protective covers and measurement nipples are mounted and fastened.
- Fill out necessary test reports.
- Instruct the persons in charge of the operation on the service and maintenance of the installation and what to do should any troubles occur.
- Inspection and service must be carried out by authorized personnel.



Review and service should be performed by authorised personnel only.

9. Fault location, functional troubles

Trouble free operation is dependent on three factors: electricity, gas and air supply. Should there be any changes in the ratio between these three factors there is a risk of break downs. It has been proved that most break downs are caused by simple faults. Before calling the service engineer, the following should therefore be checked:

- Is the gas cock open?
- Are all fuses in order and the current switched on?
- Are the thermostats correctly set?
- Are pressostats, overheating protection etc. in operating position and not locked-out?
- Is the gas pressure sufficient?
- Is the gas burner control in start position?
- Has the gas control or the motor protector locked out? - Reset.
- Is the circulation pump in operation?
- Is there a supply of fresh air to the installation?
- If integral components are of a different make from what is stated in this manual, see the enclosed loose-leaf.

10. Electric equipment

Safety system

Safety systems must be installed in accordance with regulations that are applicable for the appliance. This may differ according to the process burner are installed in to. Se local regulations for information.

Safety system cables must be run in separate cables outgoing signal must not come in same cable as incoming signal. Signals must be in different harnesses for safety reasons.

Safety system as door switches, water level, pressure, temperature and other safety limiters must be installed in safety loop according to process.

10.1 Wiring diagram LME...

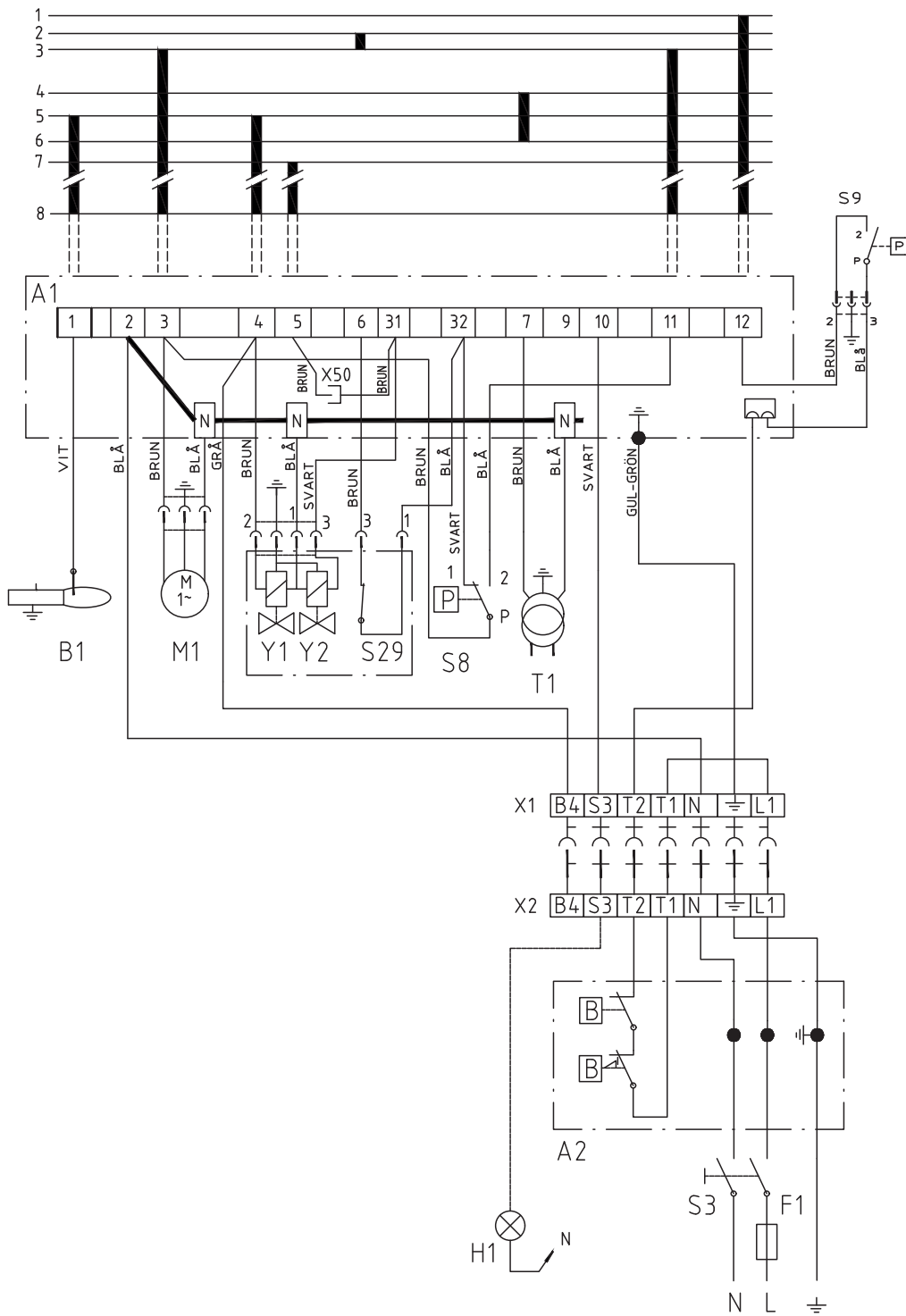

10.1.1 List of components

A1	Gas burner control	S29	CPI
A2	Twin thermostat	T1	Ignition transformer
B1	Ionization electrode	X1	Plug-in contact, burner
F1	Fuse	X2	Plug-in contact, boiler
H1	Alarm, 230 V	X50	Pilot test link
M1	Burner motor	Y1	Gas solenoid valve
S3	Main switch	Y1S	Safety solenoid valve
S8	Air pressure switch		

10.2 Function LME...

<p>1. Operating switch ON-Thermostat ON-Gas pressure switch ON A check that the air pressure switch does not indicate fan pressure is carried out</p>
<p>2. Burner motor starts A check that the air pressure switch indicates sufficient fan pressure is carried out</p>
<p>3. The ignition spark is created</p>
<p>4. The gas solenoid valve is open The gas is ignited. The ionisation electrode now indicates a flame</p>
<p>5. The safety time expires The ignition spark ceases. The safety period ceases. If the spark is missing or it disappears after this time limit, the gas burner control is blocked</p>
<p>6. Operating position</p>
<p>7. Stop The operation of the burner can now be stopped with the control switch or thermostat</p>
<p>If the gas burner control is blocked Red light in the gas burner control is lit. The burner is restarted by pushing the reset button</p>

 Mains connection and fuse in accordance with local regulations.

10.2.1 Technical data

	LME21.130C2	LME21.550C2
Preignition time	2 s	2 s
Prepurge time	7 s	50 s
Postignition time	2.5 s	4.5 s
Safety lockout time	< 3 s	< 5 s
Reset time after lockout	< 1 s	< 1 s
Reaction time on flame failure	< 1 s	< 1 s
Min. ionisation current at flame	5 µA	5 µA
Max. ionisation current	20 µA	20 µA

160303-317

10.3 Control program when disruption; Disruption display, Gas burner control: LME....

Colour codes

Colour code table for multi-coloured signal lamps (Light diodes)		
Status	Colour codes	Colours
Waiting time «tw», other waiting times	○.....	Off
Ignition phase, ignition checked	•○ •○ •○ •○ •	Flashing yellow
Normal operation	□.....	Green.
Operation, poor flame signal	□□□□□□□□	Flashing green
Prohibited flame signal during start up	□▲□▲□▲□▲□▲	Green-Red
Undervoltage	●▲●▲●▲●▲●▲	Yellow-Red
Disruption, alarm	▲.....	Red.
Flashing code for fault codes	▲○ ▲○ ▲○ ▲○	Flashing red
Interface diagnostics	▲▲▲▲▲▲▲▲	Red flickering

.....	Continuous
○	Off
▲	Red
●	Yellow
□	Green

Diagnostics alarm trigger

The red alarm signal lamp lights continuously after the alarm is disconnected.

Diagnostics for alarm triggers can be read as specified by the following sequence:

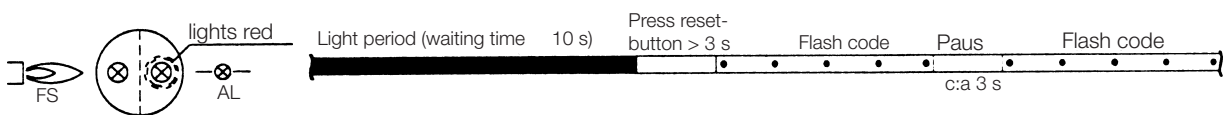

7.2.1.2 Limiting of starting repetitions

LME ... has a function with start repetition if the flame is not created at start ord disappears during operation.. LME ... allows max. three repetitions during coninuous starting cycle

Alarm control table

Red flashing code on signal lamp (LED)	Possible causes
Flashing 2 x ●●	No flame at End of «TSA» - Defective or obscured flame monitor - - Defective or obscured fuel valves - Poor burner installation - Defective ignition unit
Flashing 3 x ●●●	«LP» defective - No air monitor signal after «t10» - «LP» is welded in the open position
Flashing 4 x ●●●●	Prohibited flame signal during start up
Flashing 5 x ●●●●●	Time out «LP» - «LP» is welded in the closed position
Flashing 6 x ●●●●●●	Free
Flashing 7 x ●●●●●●●	Too many loss of flame during operation - Poor burner installation - Defective or obscured fuel valves - Defective or obscured flame monitor
Flashing 8 x ●●●●●●●●	Free
Flashing 9 x ●●●●●●●●●	Free
Flashing 10 x ●●●●●●●●●●	Connection fault or internal fault, outgoing contacts or other fault
Flashing 14 x ●●●●●●●●●● ●●●●	CPI contact not closed

During alarm trigger diagnostics, control outputs are to be disconnected from all power.

- The burner is disconnected
- Exception, the «AL» alarm signal at connection block 10
- The burner is only to be reconnected after it is reset -
- Press the reset button 0.5...3 s.

Interface diagnostics

To switch to interface mode, hold the reset button depressed for more than 3 s. To return to normal mode, hold the reset button depressed for more than 3 s. If the firing unit is in the alarm mode, it is reset by pressing the reset button 0.5...3 s.

11. Troubleshooting

Gas Burner

Conditions favourable to disruption-free operation of the system can only be guaranteed through the interaction between three factors – electricity, gas flow and combustion air. A change in any of these factors may cause disruptions.

It has been shown that a large proportion of disruptions can be attributed to relatively small things. Therefore, before requesting servicing, you should ascertain the following:

1. Are the system's gas taps open?
2. Are the fuses intact and is the power on?
3. Are control devices (room thermostat, boiler thermostat, etc.) correctly set?
4. Is gas pressure to the burner sufficient?
5. Are the burner controls on standby and not locked?
6. Is air supply to the burner adequate?

Cause of fault	Action
Burner does not start:	
No gas.	Make sure all gas taps are open.
No power.	Check the fuse, thermostat and electrical connections.
Burner motor does not start.	Motor protection has tripped. Motor faulty.
Burner control faulty.	Replace.
Burner motor running, no ignition spark at the end of pre-aeration:	
No power in the terminals.	Check the connector. Replace faulty burner controls.
Ignition electrodes in contact with each other or earth.	Adjust.
Ignition electrode porcelain damaged.	Replace the electrodes.
Poor connection to cable connectors.	Adjust connection.
Ignition cables damaged.	Replace.
Transformer damaged, no power to secondary winding.	Replace the transformer.
Ignition cable and ionisation cable swapped around.	Reconnect.
No flame propagation:	
Gas solenoid valve faulty.	Replace.
Gas solenoid valve does not open despite having power.	Replace solenoid valve terminals, or entire valve.
No power to solenoid valve.	Check the connection.
No electrical connection through air pressure gauge.	Check the air pressure gauge's settings and functions.
Ignition load incorrectly set.	Increase/decrease gas supply Reduce airflow.
Burner control faulty	Replace
Air pressure gauge incorrectly set or faulty	Check the settings and reset, or replace
No acknowledgement signal due to incorrect adjustment or misalignment of the control motor cams.	Check the settings and realign.

Cause of fault	Action
Burner trips after safety time limit despite flame propagation:	
No ionisation current or UV cell incorrectly positioned.	Adjust ionisation electrode and UV cell Check cables and connectors.
Burner control monitor faulty.	Replace burner control.
Voltage lower than 185 V.	Contact an electrician.
Ignition electrodes disrupting ionisation current.	Adjust ignition electrodes. Re-polarise the transformer.
Poor earth connection.	Ensure adequate earth connection.
Phase and neutral swapped around.	Check wiring diagram and change accordingly.
Burner trips during pre-aeration:	
Air sensor faulty or incorrectly set.	Increase/decrease air setting. Reduce air volume.
Ignition load incorrectly set.	Increase/decrease gas supply Reduce airflow.
Gas pressure too low.	Increase pressure. If necessary, contact gas supplier.
Pulsations at start-up:	
Ignition electrodes incorrectly set.	Adjust .
Gas pressure too high.	Check and adjust using pressure gauge and pressure control valve.
Flue gas side blocked.	Check the chimney flue.
Burner pulsates during operation:	
Burner incorrectly set.	Adjust.
Burner dirty.	Clean the burner.
Incorrect chimney.	Check and modify dimensions if necessary.
Burner functioning properly but with occasional blockage:	
Ionisation current too low.	Check. Must be at least 6 μA , but should ideally lie between 8 and 20 μA .
UV cell incorrectly positioned.	Adjust.
Voltage drop at certain times.	Must not drop below 15% of rated voltage. Contact an electrician if necessary.
Incorrectly set or faulty air sensor.	Check the settings and reset, or replace.
Ignition electrode overload.	Replace.
Burner control ambient temperature too high.	Insulate for heat, Max. 60 °C.
Ignition spark too weak.	Check the transformer.
Poor combustion:	
Poor draught conditions.	Check the chimney.
Flue gas temperature too high.	Boiler overloaded Decrease the gas volume, sweep the chimney if necessary.
CO ₂ content too low.	Choke the air supply. Check the boiler for any leakages. Choke the draught if too high.

Cause of fault	Action
CO content too high:	
Surplus air when using natural gas and liquefied petroleum (propane, butane).	Choke the air supply.
Poor air supply.	Open the air supply. Check flue gas damper.
Holes in gas nozzle clogged.	Clean.
Poor fresh air intake.	Check and increase.
Flame at incorrect angle due to combustion head out of position.	Check the combustion head and readjust.
Condensation build up in boiler and chimney:	
Flue gas temperature too low or gas volume too low.	Raise the flue gas temperature by increasing gas volume Insulate the chimney.

12. General instructions for gasburners

12.3.1 Installation

1. Follow standards and instructions applicable to the installation of gas burners.
2. Ensure that the electric installation is made in accordance with existing regulations.
3. Check that the fresh air intake of the boiler room is sufficiently dimensioned.
4. Check by studying the data plate that the efficiency of the burner is adapted to the boiler output.
5. Check that the burner is adapted to the gas quality in question.
6. Check that the input pressure of the gas is correct.
7. Check that the dampers of the boiler are open.
8. Check that there is water in the system.
9. Check that thermostats etc. are correctly adjusted.
10. Read the instructions and follow the directions given for the burner as to starting-up and service.

12.3.2 Maintenance

General instructions

1. Keep the boiler room clean.
2. Ensure that the fresh air intake of the boiler room is not restricted.
3. Switch off the current and shut off the gas supply if the burner must be withdrawn from the boiler.
4. Do not use the boiler for burning paper and waste if there is no special arrangement (fire room) for this.

Normal operation

1. Ensure that the air supply to the burner is not obstructed by dust and dirt.
2. Have the installer make a yearly overhaul of the installation so that safety is not jeopardized.
3. Have the installer at the yearly overhaul also adjust the burner to ensure optimal combustion economy.
4. Check periodically that there is water in the system (fill up if necessary) and that thermostats etc. are normally adjusted.
5. Ensure that there is no water or dampness in contact with the burner.

12.3.3 If the burner has stopped

1. Press the reset button of the relay.
2. Check that the max. thermostat has not cut out.
3. Check other thermostats for example room thermostat, if any.
4. Check that the gas pressure to the burner is sufficient.
5. Check that the electric fuses have not blown.
6. Make a new attempt to start the burner and check the counter of the gas meter to find out whether the solenoid valve opens.
7. If the burner does not start in spite of repeated starting attempts call the installer.

12.3.4 Shut-Off

1. Switch off the current with the main switch.
2. Shut-off the gas supply with the shut-off cock on the burner.

12.3.5 Warning

1. Never keep your face in front of the fire room door when starting up the burner.
2. Do not use naked flame when inspecting the fire room.

Authorized installer::

Address:

Telephone:

EU Declaration of conformity



Bentone Gas Burners

Certificate No.	Type	Certificate No.	Type
CE-0123CT1269	BFG 1	CE-0123CT1326	BG 550
CE-0123CT1270	STG 120	CE-0123CT1337	BG 600
CE-0123CT1281	STG 146	CE-0123CT1348	BG 650
CE-0123CT1292	BG 300	CE-0123CT1359	BG 700
CE-0123CT1304	BG 400	CE-0123CT1360	BG 800
CE-0123CT1315	BG 450	CE-0123CT1371	BG 950

This declaration of conformity is issued under the sole responsibility of the manufacturer. The object of the declaration described above is in conformity with:

Gas Appliance Regulation 2016/426/EU

Machinery Directive 2006/42/EC

EMC 2014/30/EU

Restriction of the use of certain hazardous substances (RoHS) Directive 2011/65/EU

References to the relevant harmonised standards used or references to the other technical specifications in relation to which conformity is declared:

EN 676+A2:2008

Excluded Annex J/K. Automatic forced draught burners for gaseous fuels

Additional information can be downloaded at:

www.bentone.com

Enertech AB

Box 309

S-341 26 LJUNGBY

Ljungby, January 26th 2021

Helene Richmond

Managing Director

Enertech AB

