



Providing sustainable energy solutions worldwide

Installation- and maintenance instruction

**B45A 2.2H**

LOA 24

A2L 65C-75C



### Manualer på övriga språk

[www.bentone.com/nedladdning](http://www.bentone.com/nedladdning)  
eller scanna QR-koden

Skriv in brännarens artikelnummer som finns på din  
typskylt (se bild) och välj ditt språk

### Manuals in other languages

[www.bentone.com/download](http://www.bentone.com/download)  
or scan QR-code

Enter the burner's article number on your data plate  
(see picture) and select language.

### Gebrauchsanweisungen in anderen Sprachen.

[www.bentone.com/download](http://www.bentone.com/download)  
oder scannen Sie den QR-Code



Geben Sie die Artikelnummer des Brenners auf Ihrem Typenschild ein  
(siehe Bild) und wählen Sie die Sprache aus.

### Manuels dans d'autres langues.

[www.bentone.com/download](http://www.bentone.com/download)  
ou scannez le code QR

Saisir le numéro d'article du brûleur  
sur votre plaque signalétique (consultez l'illustration)  
et sélectionnez la langue.

exempel example Beispiel

352011030141	Serial no. 1234567	Man.Year 2019
Designation	BF 1 KS 76-24	
Type	BF 1	
Model	BF 1 KS 76-24	
Cap. Min-Max	LIGHT OIL 35-90kW 1,25-6,0 cSt 7-14bar	
Main supply	1-230V 1,0A 50Hz IP 20	
Motor supply		
MADE IN SWEDEN BY		



# Table of contents

<b>1. General Information</b>	<b>4</b>
<b>2. Technical data B 45A 2.2H</b>	<b>7</b>
2.1 Dimensions B 45	7
2.2 Working field B 45 A2.2H	8
2.3 Setting of brake plate and air flow	9
2.4 Recommended nozzle and pressure	9
2.5 Burner installation	9
2.6 Nozzle table	10
2.7 Description B 45 A2.2H	12
<b>3. General instructions</b>	<b>14</b>
3.1 General rules	14
<b>4. Installation</b>	<b>15</b>
4.1 Handling and lifting instruktion	15
4.2 Acceptance inspection	16
4.3 Preparations for installation	16
4.4 Distribution of oil	16
4.5 Electrical connection	16
4.6 Mount the burner on the boiler	17
4.7 Check oil line seals	17
4.8 Adjusting the air setting	18
<b>5. Burner installation</b>	<b>19</b>
5.1 Examples of basic setting B 45 2.2H	19
5.2 Setting values for nozzle assembly and air damper B 45 2.2H	20
<b>6. Burner servicing</b>	<b>21</b>
6.1 Servicing the combustion assembly	21
6.2 Servicing air dampers	22
6.3 Servicing the fan	23
6.4 Replacement of oil pump	24
6.5 Vibration	25
<b>7. Instructions Pump</b>	<b>26</b>
7.1 SUNTEC A2L 65C - 75C	26
<b>8. Replacement of electrical components</b>	<b>32</b>
<b>9. Oil burner control</b>	<b>33</b>
9.1 Wiring diagram	33
9.2 List of components	34
<b>10. Fault Location</b>	<b>36</b>
10.1 Burner will not start	36
10.2 Burner will not start after normal use	36
10.3 Delayed ignition	37
10.4 Noise in pump	37
10.5 Pump pressure	38
<b>11. Log of flue gas analysis</b>	<b>39</b>
<b>12. Oil burners maintenance instructions</b>	<b>40</b>

# 1. General Information

This Installation and Maintenance manual:

- is to be regarded as part of the burner and must always be kept near the installation site.
- is intended for use by authorised personnel.
- must be read prior to installation.
- must be observed by all who work with the burner and associated system components.
- work with the burner may only be carried out by certified installers/ personnel.
- Enertech AB is not liable for any typographical errors and reserves the right to make design changes without prior notice.
- The burner may only be used for its intended purpose in accordance with the product's technical data.
- The burner may only be installed and operated by authorised personnel.
- The product is packaged to prevent damage from occurring during handling. Handle the product with care. Lifting equipment must be used to lift larger packages.
- The products must be transported/stored on a level surface in a dry environment, max. 80% relative humidity, no condensation. Temperature -20 to +60 °C.
- Check that the burner is compatible with the boiler's output range.
- The label information on the rating plate refers to the burner's minimum and maximum power.
- The power data on the type sign refers to the burner's min. and max. power.
- All components must be installed without being bent, twisted or subjected to mechanical or thermal forces which can affect the components.
- The burner must be installed so that it complies with local regulations for fire safety, electrical safety, and fuel distribution.
- Make sure when installing the equipment that there is enough space to service the burner.
- Permitted ambient temperature during operation -0 to +60 °C. Max 80% relative humidity, no condensation.
- The installer must ensure that the room has adequate air supply.
- The room must comply with local regulations pertaining to its intended use.
- The installation site must be free of chemicals.
- Burner pipes, fan wheels and air dampers may contain sharp edges.
- The surface temperature of the burner's components can exceed 60 °C.
- Caution: The burner has moving parts, and there is risk of crushing injuries.



165 105 01

- The electrical installation must be professionally carried out in accordance with applicable high voltage regulations, as per Enertech's recommendations.
- Before servicing, shut off the fuel supply and turn off the power to the burner.
- Leak checks must be performed during installation and servicing to prevent fuel leakage.
- Care should be taken by the installer to ensure that no electrical cables or fuel lines are crushed or otherwise damaged during installation or servicing.
- If the boiler is equipped with an access hatch, this must be equipped with a hatch opening switch connected to the burner's safety system.
- When in operation, the burner's noise level can exceed 85 dBA. Use hearing protection.
- The burner must not be put into operation without proper safety and protection devices.
- A Class BE fire extinguisher is recommended.
- It is forbidden to alter the design or use accessories which have not been approved by Enertech in writing.
- Prior to operation, the following points must be checked:
  - fitting and installation work has been completed and approved.
  - electrical installation has been correctly performed.
  - flue gas ducts and combustion air ducts are not blocked.
  - all actuators and control and safety devices are in working order and correctly set.
- After commissioning, if a steady red light on the burner control is displayed, contact your installation technician.



## Burner servicing schedule

Servicing must be carried out once a year or after 3000 hours of operation.

Burner	1 year	3000 hrs
Filter	1 year	3000 hrs Change
Oilhose	1 year Control/change	
Nozzle	1 year Change	3000 hrs Change
Electrods	1 year Change/cleaning	3000 hrs Change/cleaning
Brake plate	1 year Change/cleaning	3000 hrs Change/cleaning
Motor	1 year	3000 hrs
Cuppling shaft	1 year Control/change	3000 hrs Control/change
Fan wheel	"1 year Change when dirty / unbalance"	"3000 hrs Change when dirty / unbalance"
Oil filter	1 year	3000 hrs Change
Oil valve	Tightness check 1 year	Replacement in case of leakage

## Component replacement intervals

Components	Service life – Recommended replacement	Service life – Recommended replacement Operating cycles
Control system	10 years	250 000 cycles
Pressure switch	10 years	250 000 cycles
Flame guard	10 years	250 000 cycles
UV flame sensor	10 000 hrs	N/A
Damper motor		500 000 cycles
Contaktor	10 years	500 000 cycles



The burner and its components must be recycled according to applicable regulations.

## Delivery check

- Make sure everything is delivered and the goods have not been damaged during transit.
- If something is wrong with a delivery, report it to the supplier.
- Transport damage must be reported to the shipping company.

## 2. Technical data B 45A 2.2H

The burner is intended for:

- Light oil, B10 heating oil/biofuel blend (as defined in DIN V51603-6)

and is used for:

- Water heating generators
- Hot air generators (these require LMO 24 255 C2E)

### 2.1 Dimensions B 45

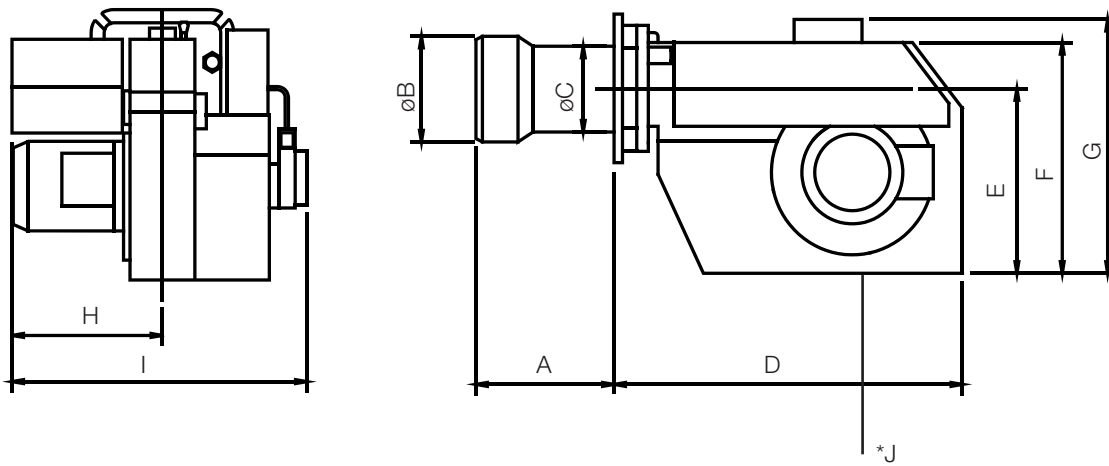

\* Min. recommended distance to floor.

	A	Ø B	Ø C	D	E	F	G	H	I	*J
<b>B 45A2</b>	240/340	159	134	480	252	328	335	262	515	200

## 2.2 Working field B 45 A2.2H

8,6-45,5 kg/h

102-540 kW

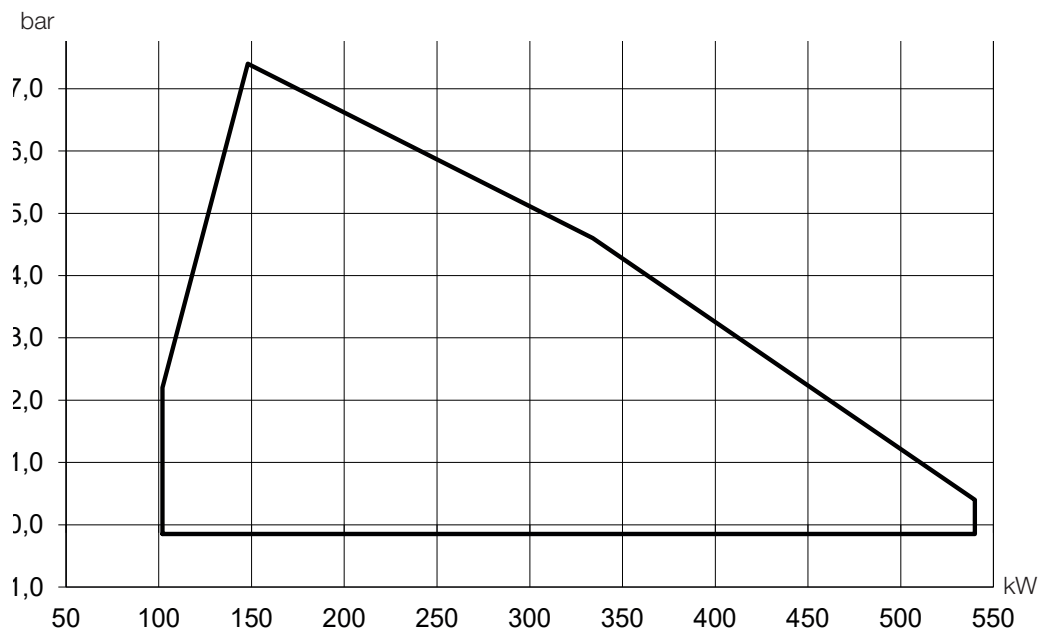

### 2.2.1 Electric Specification

Burner correspond to IP 20

Type	Motor	Complete burner	Sound
<b>B 45</b>	450W 230V 50/60Hz 10μF	230V 4,63 A 50Hz	84 dBA ± 0,5 dBA

Max current , see data plate



## 2.3 Setting of brake plate and air flow

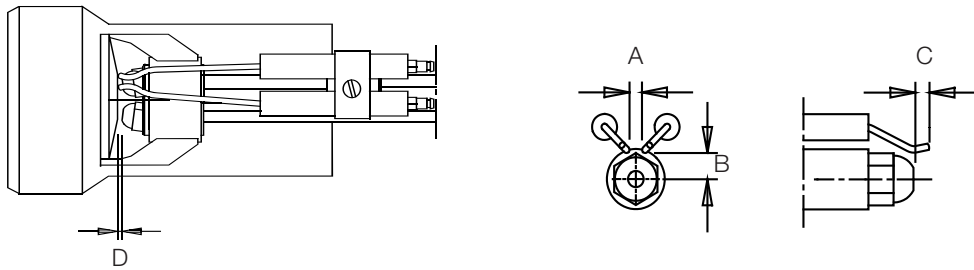

	a	b	c	d
B45A 2	3,5-4,0	7,0-9,0	2,0-3,0	5,0-6,0

**!** \*NB It is important that the spark does not strike against the brake plate or nozzle

## 2.4 Recommended nozzle and pressure

Because of the various boiler types with varying furnace geometries and furnace loads, it is impossible to commit to a certain scattering angle or a specific distribution pattern.

It should be noted that the scattering angle and distribution pattern changes with pump pressure.

Nozzle:	45° Solid/semisolid
	60° Solid/semisolid
	80° Solid/semisolid
Pump pressure	14 bar (8-25 bar) depending on pump model

## 2.5 Burner installation

### 2.5.1 Hole patten

Make sure the hole patten on the boiler is designed for burner flange.

Combustion device	$d_1$	$d_2$	$d_3$
B 45A 2	ø (135) 165	M14	ø (200) 224-270

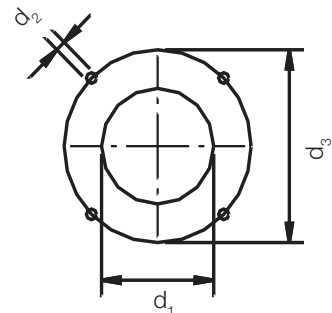

## 2.6 Nozzle table

Pump pressure bar 10				11			12			13		
Gph	kg/h	kW	Mcal/h	kg/h	kW	Mcal/h	kg/h	kW	Mcal/h	kg/h	kW	Mcal/h
1,00	3,72	44	38	3,90	46	40	4,08	48	42	4,24	50	43
1,10	4,09	48	42	4,29	51	44	4,48	53	46	4,67	55	48
1,20	4,47	53	46	4,68	55	48	4,89	58	50	5,09	60	52
1,25	4,65	55	47	4,88	58	50	5,10	60	52	5,30	63	54
1,35	5,02	59	51	5,27	62	54	5,50	65	56	5,73	68	58
1,50	5,58	66	57	5,85	69	60	6,11	72	62	6,36	75	65
1,65	6,14	73	63	6,44	76	66	6,73	80	69	7,00	83	71
1,75	6,51	77	66	6,83	81	70	7,14	85	73	7,42	88	76
2,00	7,45	88	76	7,81	93	80	8,16	97	83	8,49	101	87
2,25	8,38	99	85	8,78	104	90	9,18	109	94	9,55	113	97
2,50	9,31	110	95	9,76	116	100	10,19	121	104	10,61	126	108
2,75	10,24	121	104	10,73	127	109	11,21	133	114	11,67	138	119
3,00	11,16	132	114	11,71	139	119	12,23	145	125	12,73	151	130
3,50	13,03	154	133	13,66	162	139	14,27	169	146	14,85	176	151
4,00	14,89	176	152	15,62	185	159	16,31	193	166	16,97	201	173
4,50	16,75	199	171	17,57	208	179	18,35	218	187	19,10	226	195
5,00	18,62	220	190	19,52	231	199	20,39	242	208	21,22	252	216
5,50	20,48	243	209	21,47	255	219	22,43	266	229	23,34	277	238
6,00	22,34	265	228	23,42	278	239	24,47	290	250	24,46	302	260
6,50	24,20	287	247	25,37	301	259	26,51	314	270	27,58	327	281
7,00	26,06	309	266	27,33	324	279	28,55	339	291	29,70	352	303
7,50	27,92	331	285	29,28	347	299	30,59	363	312	31,83	377	325
8,00	29,79	353	304	31,23	370	318	32,63	387	333	33,95	403	346
8,50	31,65	375	323	33,18	393	338	34,66	411	353	36,07	428	368
9,00	33,59	398	343	35,14	417	358	36,71	435	374	38,19	453	389
9,50	35,37	419	361	37,09	440	378	38,74	459	395	40,31	478	411
10,00	37,23	441	380	39,04	463	398	40,78	484	416	42,44	503	433
11,00	40,96	486	418	42,94	509	438	44,86	532	457	46,68	554	476
12,00	44,68	530	456	46,85	556	478	48,94	580	499	50,92	604	519
14,00	52,12	618	531	54,65	648	557	57,10	677	582	59,41	705	606
16,00	59,57	706	607	62,46	741	637	65,26	774	666	67,90	805	692
18,00	67,02	795	683	70,27	833	717	73,41	871	749	76,39	906	779
20,00	74,47	883	759	78,08	926	796	81,57	967	832	84,87	1007	865
22,00	81,91	971	835	85,89	1019	876	89,73	1064	915	93,36	1107	952
24,00	89,36	1060	911	93,70	1111	956	97,88	1161	998	101,85	1208	1039
26,00	96,81	1148	987	101,50	1204	1035	106,04	1258	1081	110,33	1308	1168

The table applies to oil with a viscosity of 4.4 mm<sup>2</sup>/s at a density of 830 kg/m<sup>3</sup>.

Pump pressure bar 14				15			16			17		
Gph	kg/h	kW	Mcal/h	kg/h	kW	Mcal/h	kg/h	kW	Mcal/h	kg/h	kW	Mcal/h
1,00	4,40	52	45	4,56	54	46	4,71	56	48	4,85	57	49
1,10	4,84	57	49	5,01	59	51	5,18	61	53	5,34	63	54
1,20	5,29	63	54	5,47	65	56	5,65	67	58	5,82	69	59
1,25	5,51	65	56	5,70	68	58	5,89	70	60	6,07	72	62
1,35	5,95	70	61	6,15	73	63	6,36	75	65	6,55	78	67
1,50	6,60	78	67	6,83	81	70	7,06	84	72	7,27	86	74
1,65	7,27	86	74	7,52	89	77	7,77	92	79	8,01	95	82
1,75	7,71	91	79	7,97	95	81	8,24	98	84	8,49	101	87
2,00	8,81	104	90	9,12	108	93	9,42	112	96	9,71	115	99
2,25	9,91	118	101	10,26	122	105	10,60	126	108	10,92	130	111
2,50	11,01	131	112	11,39	135	116	11,77	140	120	12,13	144	124
2,75	12,11	144	123	12,53	149	128	12,95	154	132	13,35	158	136
3,00	13,21	157	135	13,67	162	139	14,13	168	144	14,56	173	148
3,50	15,42	183	157	15,95	189	163	16,49	196	168	16,99	201	173
4,00	17,62	209	180	18,23	216	186	18,84	223	192	19,42	230	198
4,50	19,82	235	202	20,51	243	209	21,20	251	216	21,84	259	223
5,00	22,03	261	225	22,79	270	232	23,55	279	240	24,27	288	247
5,50	24,23	287	247	25,07	297	256	25,91	307	264	26,70	317	272
6,00	26,43	313	270	27,49	326	280	28,27	335	288	29,13	345	297
6,50	28,63	340	292	29,63	351	302	30,62	363	312	31,55	374	322
7,00	30,84	366	314	31,91	378	325	32,98	391	336	33,98	403	374
7,50	33,04	392	337	34,19	405	349	35,33	419	360	36,41	432	371
8,00	35,25	418	359	36,47	433	372	37,69	447	384	38,80	460	396
8,50	37,45	444	382	38,74	459	395	40,04	475	408	41,26	489	421
9,00	39,65	470	404	41,02	486	418	42,40	503	432	43,69	518	446
9,50	41,85	496	427	43,30	514	442	44,75	531	456	46,11	547	470
10,00	44,06	523	449	45,58	541	465	47,11	559	480	47,11	559	480
11,00	48,46	575	494	50,14	595	511	51,82	615	528	53,40	633	545
12,00	52,87	627	539	54,70	648	558	56,53	670	576	58,25	691	594
14,00	62,68	732	629	63,81	757	651	65,95	778	669	67,96	806	693
16,00	70,49	836	719	72,93	865	744	75,38	894	769	77,67	921	792
18,00	79,30	940	809	82,05	973	837	84,80	1006	865	87,38	1036	891
20,00	88,11	1045	899	91,17	1081	930	94,22	1117	961	97,09	1151	990
22,00	96,92	1149	988	100	1189	1023	104	1229	1057	107	1267	1089
24,00	106	1254	1078	109	1297	1116	113	1341	1153	116	1382	1188
26,00	115	1359	1168	119	1406	1209	122	1453	1249	126	1497	1287

The table applies to oil with a viscosity of 4.4 mm<sup>2</sup>/s at a density of 830 kg/m<sup>3</sup>.

## 2.7 Description B 45 A2.2H

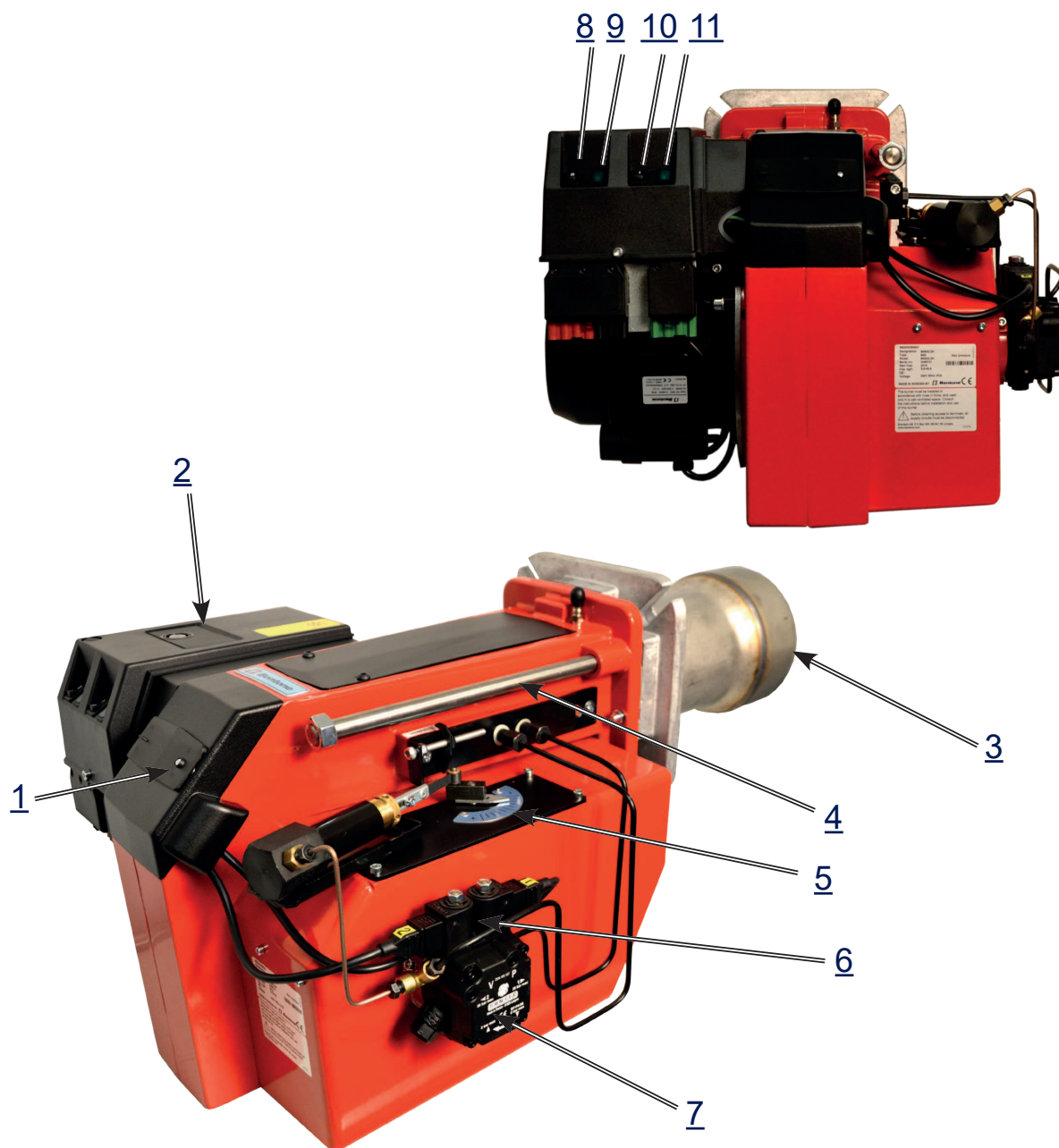

1. Inspection glass
2. Electric box
3. Blast tube
4. Gejder
5. Scale
6. Solenoid valve
7. Pump
8. Switch I-0

9. Indicator lamp Stage 1
10. Switch I-II
11. Indicator lamp Stage 2
12. Brake plate
13. Ignition electrodes
14. Fan wheel
15. Ignition transformer
16. Nozzle

17. Damper motor
18. Connecting pipe Stage 2
19. Connecting pipe Stage 1
20. Air intake
21. Air damper

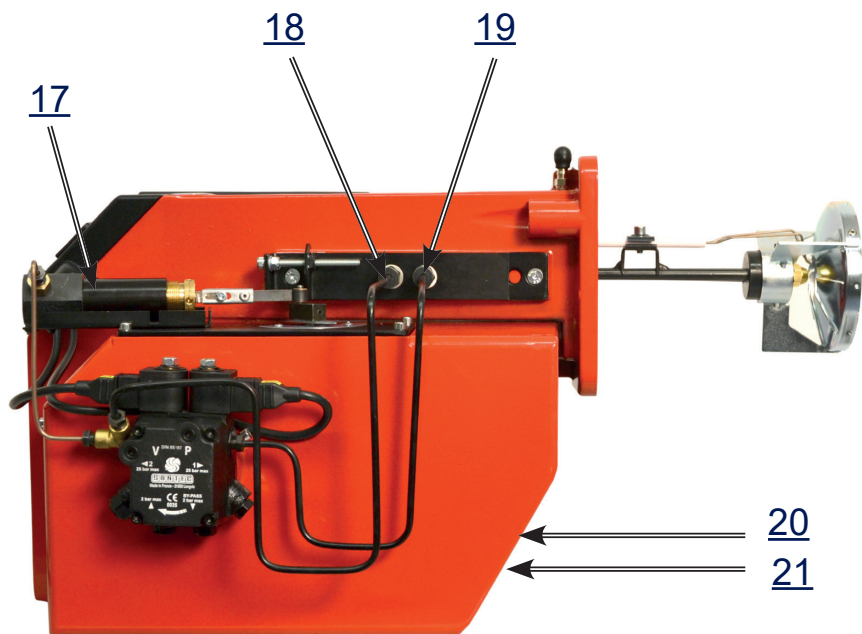
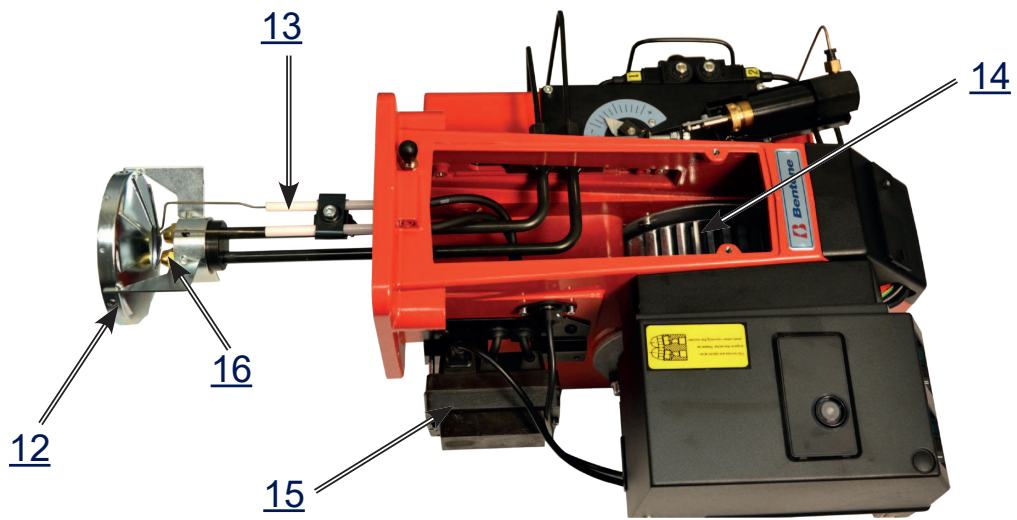

## 3. General instructions

### 3.1 General rules

The installation of an oil burner should be carried out in accordance with local regulations. The installer of the burner must therefore be aware of all regulations relating to oil and combustion.

Only oil suitable for the burner should be used and then in combination with a suitable oil filter before the oil pump of the burner.

If the burner is replacing an existing burner make sure that the oil filter is replaced or cleaned. The installation must only be undertaken by experienced personnel. Care should be taken by the installer to ensure that no electrical cables or fuel/gas pipes are trapped or damaged during installation or service/maintenance.

#### 3.1.1 Installation and maintenance instructions

The maintenance instructions supplied with the burner must be kept at an easily accessible location in the boiler room.

#### 3.1.2 Instructions

The user must be receive detailed instructions concerning the functionality of the oil burner and entire system. It is the responsibility of the supplier to provide the user with instructions.

#### 3.1.3 Inspection and maintenance

The boiler/burner should be examined regularly for any signs of malfunction or oil leakage. (See service schedule)

#### 3.1.4 Start up

In order to obtain the correct setting, a flue gas analysis and temperature measurement must be carried out. Otherwise, there is a risk of soot build up, poor efficiency or condensation precipitation in the chimney. The system must be fine-tuned at start-up. The temperature in the chimney must be at least 60 °C at 0.5 m down in the chimney to prevent condensation.

## 4. Installation

### 4.1 Handling and lifting instruktion

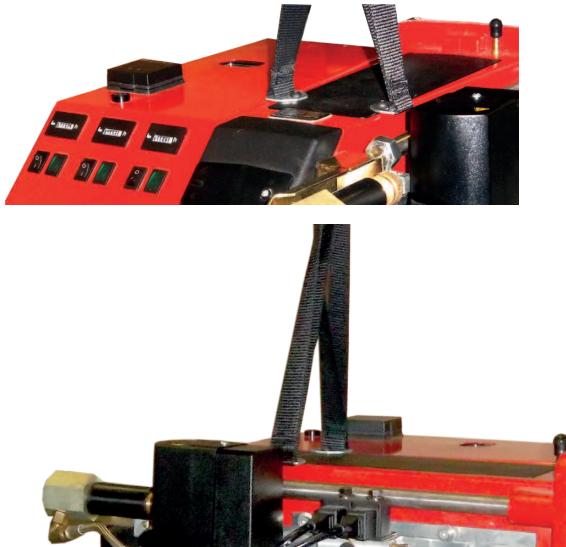

#### Option

The lifting aid we used here are available as spare parts, Figure 1.



figure 1

## 4.2 Acceptance inspection

Make sure everything is delivered and the goods have not been damaged during transit. If something is wrong with the delivery, report it to the supplier. Transport damage must be reported to the shipping company.

## 4.3 Preparations for installation

Check that the burner's dimensions and capacity range are suitable for the boiler in question. The power data on the type sign refers to the burner's min. and max. power.

## 4.4 Distribution of oil

In order to achieve good reliability, it is important that the oil distribution system is designed correctly.

Take the following into account:

- Selection of pipe diameter, pipe length and height difference; see Pump instruction.
- Pipelines are to be laid with a minimal number of glands.
- The pipes are to be laid so that the oil supply hoses are not subjected to tensile stresses or are excessively bent when the burner is swung out or removed for service.
- The oil filter should be installed so that the filter cartridge can easily be replaced or cleaned. Self-cleaning filters are recommended for oils of a higher viscosity or oils that contain significant impurities.
- Oil-affected parts shall be selected in materials that are capable of withstanding the medium's physical properties.
- When installing oil hoses, check that the inlet and return hoses are fitted to the appropriate connection on the oil pump. The hoses shall be located so that they do not bend or become subject to tensile load.
- Bleed the oil system. The oil pump/oil preheater may be damaged if run dry. The vacuum should not fall below 0.3 bar in the suction line during start-up.

 The oil filter must be installed before the burner's oil pump.

 Be sure to fill the burner oil system before starting it for the first time.

## 4.5 Electrical connection

- Before work on the electrical connection, the current should be disconnected so that the installation is isolated.
- Electrical connection must be done in accordance with the applicable regulations.
- Burners should be connected to an isolator switch.
- The connection should be made in accordance with the wiring diagram.
- Fuse rating is as required

 If any electrical connection is used other than that recommended by Bentone, there may be a danger of damage to property and personal injury.



## 4.6 Mount the burner on the boiler

1. Separate the burner body and the flange.
2. Remove the brake disc from the oil pipe.
3. Install the selected nozzle. (See Technical data)
4. Install the brake disc on the oil pipe
5. Remove the burner pipe from the flange.

**!** If the burner tube must be installed from the inside of the boiler, this means that the boiler must be opened or have a spectacle flange that is designed so that it can be reconnected with the burner tube mounted.

6. Install the flange with gasket on the boiler.
7. Install the burner pipe on the flange. Make sure that the holes in the front edge of the burner pipe are pointing down (not on all burner pipes). This allows any drops of oil to run out.
8. Insulate between the burner and boiler door to reduce radiated heat.
9. Install the burner body on the flange.
10. Lock the burner body using with the nut/nuts.
11. Connect the oil pipes to the pump, refer to the chapter - servicing of burners
12. Connect the burner electrically, refer to the chapter - servicing of burners

## 4.7 Check oil line seals

Once the burner has been installed and commissioned, the seals of the various coupling elements should be checked (A).

When a leak is detected, it is usually sufficient to tighten the coupling element that is leaking.

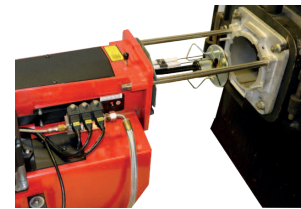
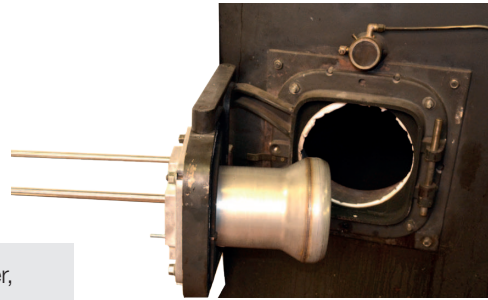

## 4.8 Adjusting the air setting

### Step 1:

1. Set the control switch (S2) to Low Load (I).
2. Loosen the screw (A), turn the damper to the desired position, and retighten the screw (A).

### Step 2:

3. Set the control switch (S2) to High Load (II).
4. Use a hex key to screw the socket (B) in to decrease or out to increase.
5. The damper position can be read on the damper scale (C).
6. Check/adjust combustion.\*

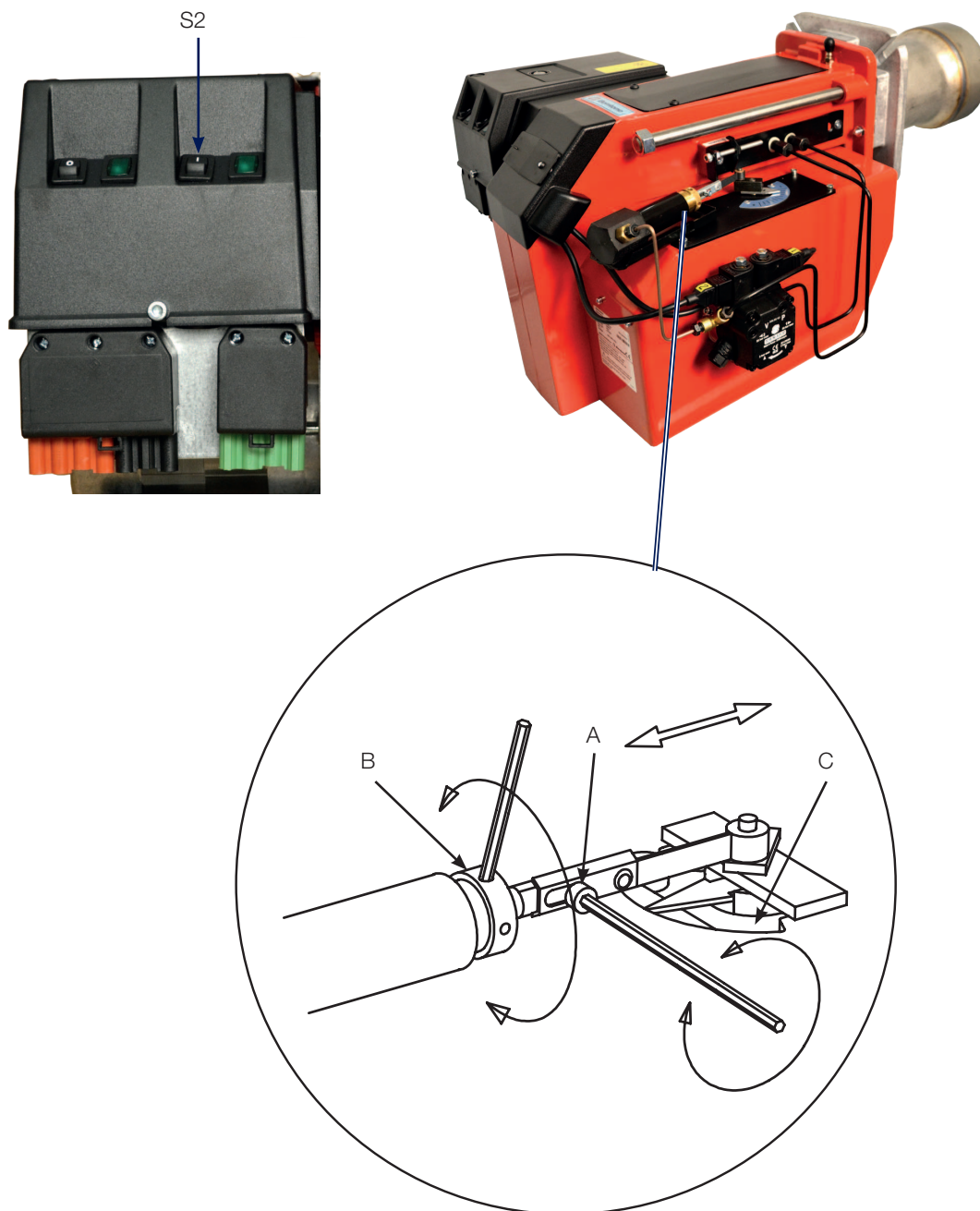

## 5. Burner installation

### 5.1 Examples of basic setting B 45 2.2H

Burner output	400kW
Estimated nozzle output	400 kW/11,86 kWh/kg*= 33,8 kg/h

Nozzle selection in accordance with the table. (See technical data) Nozzle selection is based on the selected pump pressure and the desired effect. According to the nozzle table, this provides the following nozzle.

Selected pump pressure	10,0 bar	
Nozzle	9,00 gph	9,00 gph distributed to two nozzles, e.g. 6.0 gph at stage-1 and 3,0 gph at stage-2

#### Basic settings

The setting value for 400 kW in accordance with basic setting tables. For the correct procedure when implementing settings, see below Nozzle assembly control, brake plate B 45-2. Air setting see below.

Basic settings should only be seen as setting values to get burner to start and establish a flame. Once the burner has started and established a flame, it will be necessary to adjust the settings so that they are adapted to the installation in question and the fuel used at the time.

#### Nozzle B45-2

Burner output	400 kW
	400 / 11,86 = 33,8 kg/h 10bar

According to the nozzle table, this provides the following nozzle.

Step 1	6,00 Gph = 265kW
Step 2	3,00 Gph = 132kW

#### Basic setting B45-2

The values are available in the tables for setting values of inserts or air dampers.

Insert	400kW = 22	
Low load air damper, orange		=55°
MV2 Open, black		=65°
Air damper step 2, red		=80°

These are the default settings and controlling the combustion will take place during operation.

Selection of power and connection between the different power stages must be selected and adjusted so that the system achieves good functionality

## 5.2 Setting values for nozzle assembly and air damper B 45 2.2H

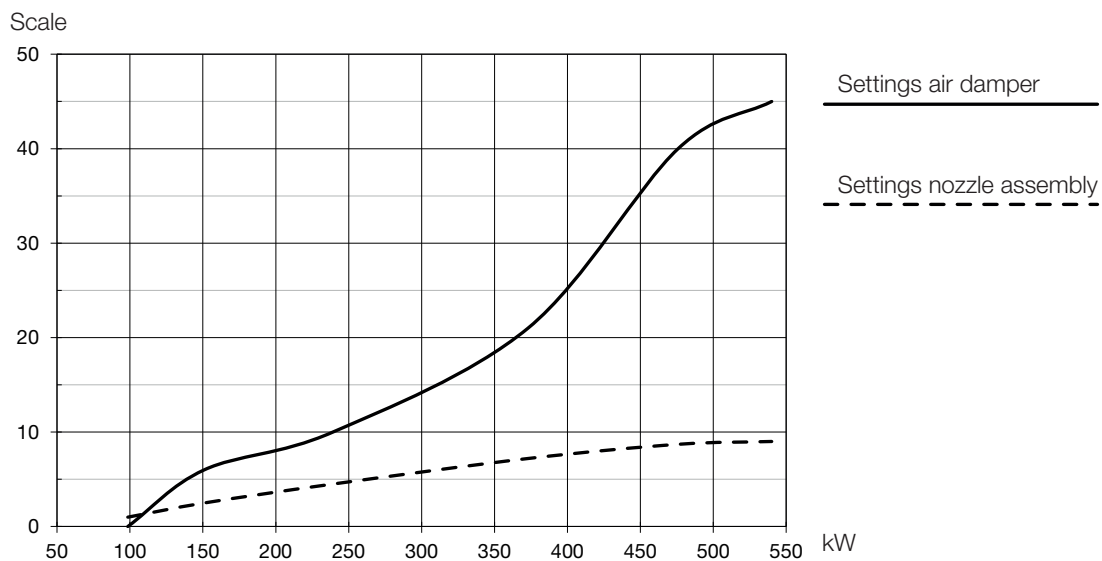

### Setting of brake disc and air flow

Prior to commissioning, the basic settings of the burner can be set in accordance with the diagram. See under Basic settings **Note that it is simply a matter of a basic setting that should be adjusted retrospectively once the burner has started.** A flue gas analysis and soot quantity measurement must be carried out when fine-tuning the burner.

### Recommended excess air

Grade of Oil	Excess air flue gases		Max. % CO <sub>2</sub>
	% O <sub>2</sub>	% CO <sub>2</sub> Lambda 1.2	
Light oil, B10 heating oil/ biofuel blend (as defined in DIN V51603-6)	3–5	≈12,5	15,4

## 6. Burner servicing

### 6.1 Servicing the combustion assembly

#### Removal and installation

1. Switch off the main power.



If the burner is directly connected, ensure that all components on the burner are without power.

2. Loosen the nut (G) and remove the burner body from the burner flange.
3. Remove the brake plate from the oil pipe and clean the brake plate.
4. Unscrew the nozzle/nozzles.
5. Install new nozzle/nozzles.
6. Install the brake plate. (see technical data)
7. Check the ignition electrodes. (see technical data)
8. If necessary, replace the ignition electrodes.
9. Fit the burner body and the burner flange together and secure with the nut (G).
10. Open the boiler/spectacle flange to access the burner pipe.
11. Remove and clean the burner pipe. Turn anticlockwise.
12. Install the burner pipe, make sure you install the drainage hole (not on all burner pipes) facing downwards so that any spilled oil can drain out.
13. Close the boiler / spectacle flange.
14. Turn on the main power.
15. Check combustion\*.



Use caution when operating the burner, surfaces may be hot.



NB: When soiled, always replace nozzles with new nozzles. Do not clean.

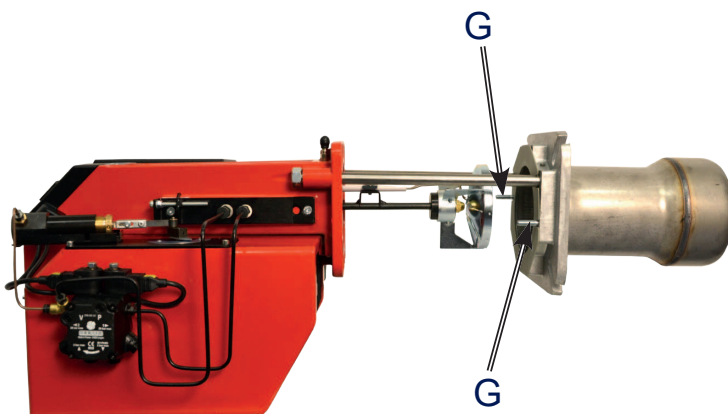

#### Note:

- \* When servicing/replacing components that affect combustion, an analysis and soot test shall be carried out on the installation.

## 6.2 Servicing air dampers

### Removal and installation

1. Switch off the mains power.

**!** If the burner is directly connected, ensure that all components on the burner are without power.

2. Note the position of the air damper and loosen the actuator locking screw (H).
3. Loosen the screws (L) securing the air damper.
4. Set the scale to 7 and lift up.
5. Clean the air damper (I) and the intake. Lubricate the damper axle bearings if necessary.
6. Refit the air damper and actuator.
7. Install the intake grille for the air intake.
8. Turn on the mains power.
9. Check/adjust combustion.\*

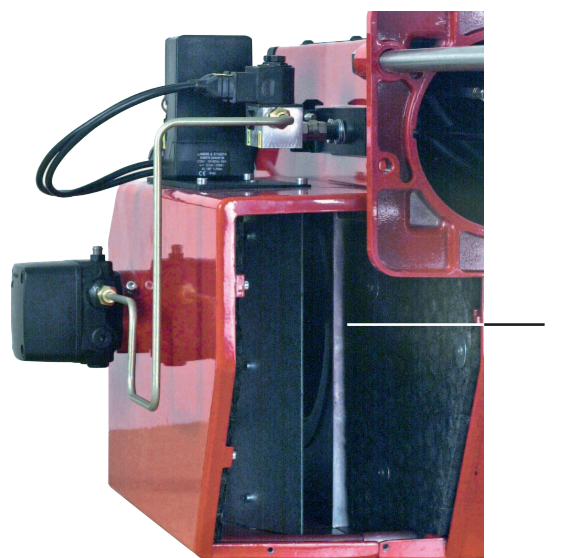
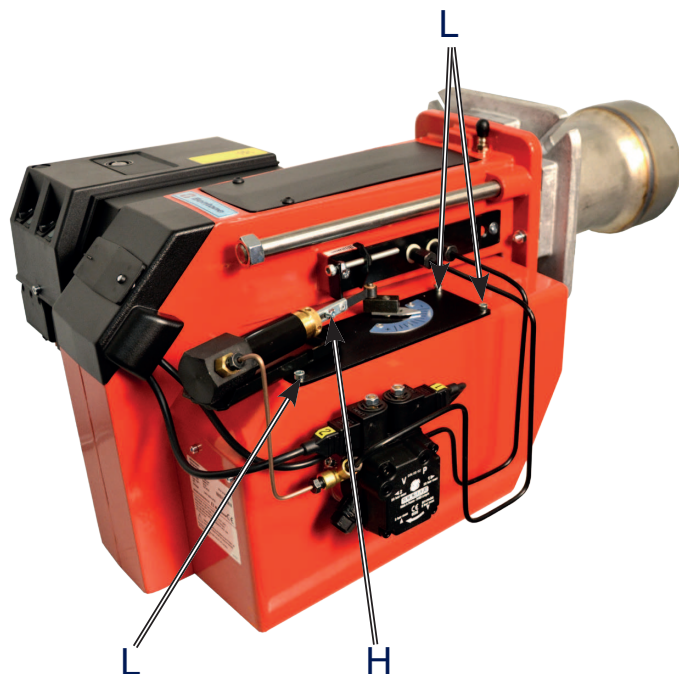

### Note:

- \* When servicing/replacing components that affect combustion, an analysis and soot test shall be carried out on the installation.

## 6.3 Servicing the fan

1. Make sure the power to the burner is switched off



If the burner is directly connected, ensure that all components on the burner are without power.

2. Detach the electrical panel
3. Disconnect the motor's electrical connection
4. Detach and remove the motor
5. Check the fan wheel to ensure it is firmly secured and not warped. Replace if damaged.
6. Clean or replace the fan wheel
7. Refit the parts, test run and check combustion



### 6.3.1 Replacing the drive shaft

#### Removal and installation

1. Make sure the power to the burner is switched off
2. Detach the electrical panel
3. Disconnect the motor's electrical cable
4. Remove the motor
5. Remove the drive shaft and drive coupling from the motor
6. Disconnect the drive coupling from the pump
7. Fit the coupling, pump, and motor. Make sure the drive shaft is connected correctly at both ends

## 6.4 Replacement of oil pump

### Removal and installation

1. Switch off the mains power.



If the burner is directly connected, ensure that all components on the burner are without power.

2. Disconnect hoses, connection pipes and electrical cables from the pump
3. Loosen the screws (J) and pull out the oil pump
4. Transfer the pump coupling to the new pump.
5. Install the oil pump on the burner and tighten the screws (J). (It is important that the pump shaft splines align correctly in the pump coupling).
6. Connect hoses, connection pipes and electrical cables
7. Turn on the mains power.
8. Bleed the pump, start the burner and set the correct oil pressure (refer to technical data for correct output).
9. Check combustion.\*

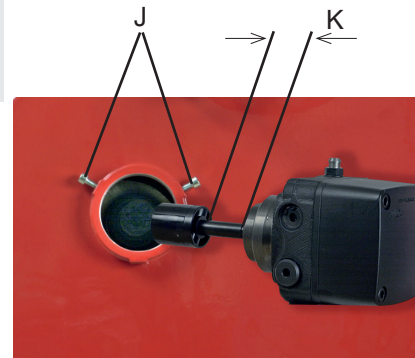

### Note:

- \* When servicing/replacing components that affect combustion, an analysis and soot test shall be carried out on the installation.



## 6.5 Vibration

Maximum vibration level are 5,0 mm/s

- Check all bolts and nuts for correct torque
- Check fan wheel for damage and contamination. Change when dirty/unbalanced
- Check motor bearings. If worn change motor/bearings

Use lid screw  
hole for sensor  
mounting

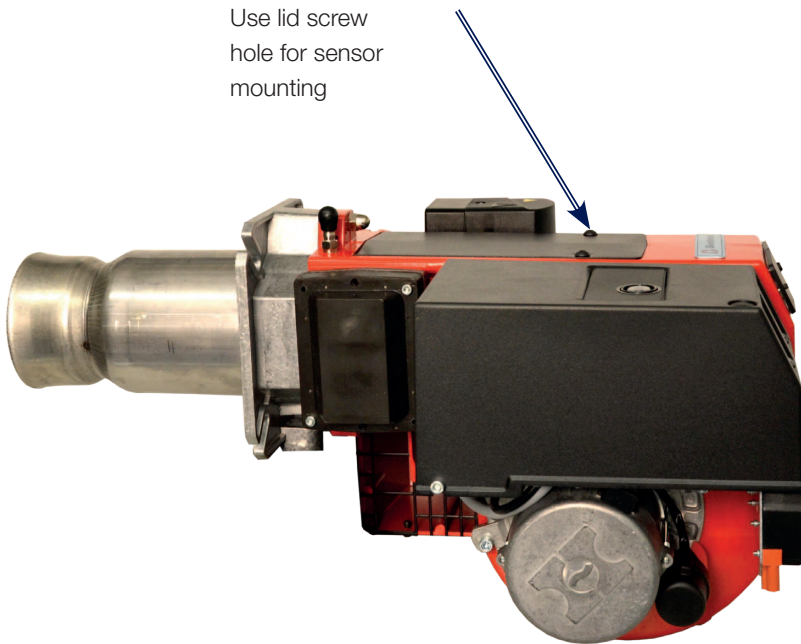

# 7. Instructions Pump

## 7.1 SUNTEC A2L 65C - 75C

### Technical data

One or two-pipe system.

Viscosity range:: 2-12 mm<sup>2</sup>/s

Pressure range:: 8-15 bar

Rated voltage of coil: 220/240V 50/60 Hz

Oil temperature:: max 60°C

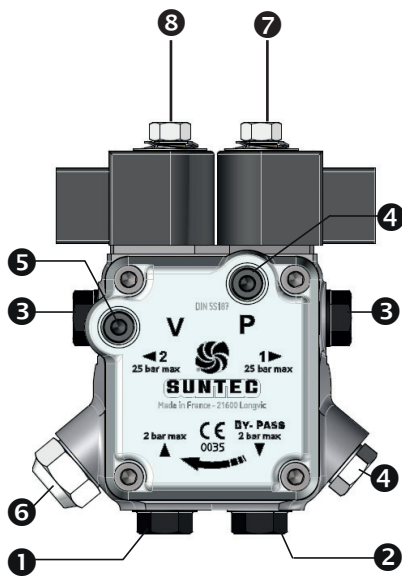

### Components

1. Suction line G 1/4"
2. Return plug
3. Nozzle outlet G 1/8" Stage 2 and stage 1
4. Pressure gauge port G 1/8"
5. Vacuum gauge port G 1/8"
6. Pressure adjustment
7. Solenoid valve 1
8. Solenoid valve 2

## Pump operating principle for A2L 65C - 75C

The SUNTEC A2L oil pump has two nozzle outlets. It incorporates two blocking solenoid

valves with in-line cut-off function, one for each nozzle outlet.

### Applications

- Light oil, B10 heating oil/biofuel blend (as defined in DIN V51603-6) and kerosene.
- Two nozzle outlets.
- Two independent blocking solenoid valves.
- A sole regulator for both nozzle lines

### Pump operating principle

The gear set draws oil from the tank through the built-in filter and transfers it to the nozzle lines via the cut-off solenoid valves. A pressure regulating valve is used to bypass all oil which is not required at the nozzles.

In two-pipe operation, the by-pass plug must be fitted in the return port, which ensures that the oil bypassed by the regulating valve is returned to the tank and the suction line flow is equal to the gear set capacity.

In one-pipe operation (by-pass plug removed and return plugged), the oil which does not go through the nozzle lines is returned directly to the gear inlet and the suction line flow is equal to the sum of the 2 nozzle flows

### Bleed

Bleeding in two-pipe operation is automatic : it is assured by a bleed flat on the piston.

In one-pipe operation, the plug of a pressure gauge port must be loosened until the air is evacuated from the system

### Cut-of

The solenoid valves of the A2L pump are of the "normally closed" type. Each solenoid valve is situated in one nozzle line. This design ensures extremely fast response and the switching can be selected according to the burner operating sequence and is independent of motor speed.

When the solenoids are non-activated, the valves are closed and all oil pressurized by the gear set passes through the regulator to suction or to the return line, depending upon pipe arrangement.

As soon as the solenoids are activated, oil passes to the nozzle lines at the pressure set by the pressure regulating valve. The two solenoid valves can be operated independently

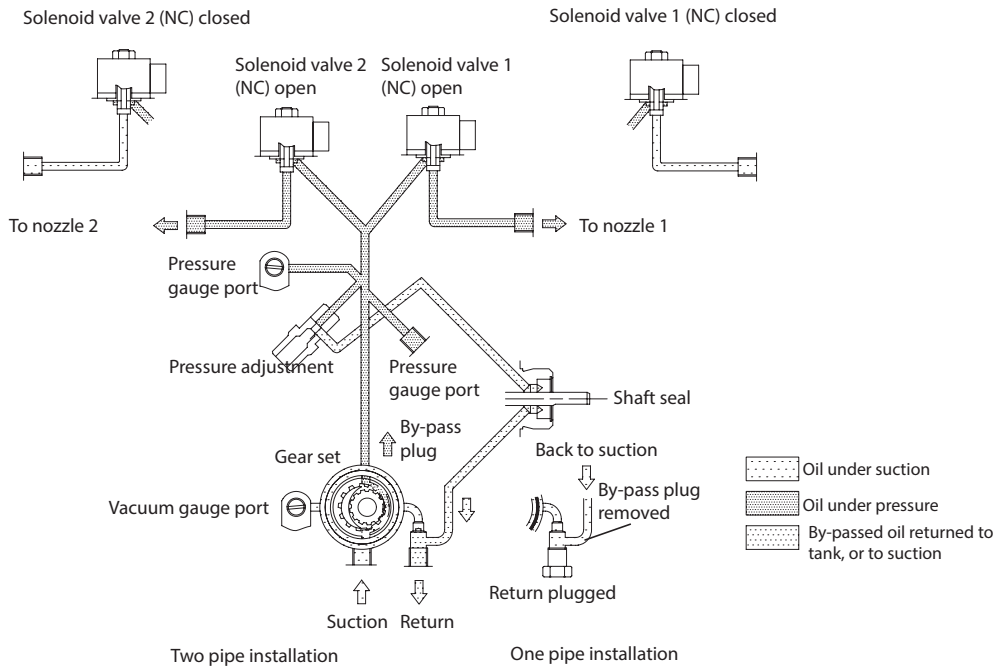

## 7.1.1 Suction line tables

### 7.1.1.1 Overlying tank

#### 1-pipe system

Nozzle*/Düse* Gicleur*/Ugello* (US GPH)	0,50		0,60		0,80		1,00		1,50		2,00		4,00			6,00			9,50	
	H (m)	d (mm)																		
0	90	75	56	45	30	150	22	113	11	56	150	7	37	119	4	23	74	150		
0,5	100	83	63	50	33	150	25	126	12	63	150	8	41	133	4	26	83	150		
1	110	92	69	55	37	150	27	139	13	69	150	8	46	146	5	28	92	150		
2	131	109	82	65	44	150	33	166	16	82	150	10	55	150	6	34	109	150		
3	152	126	95	76	50	150	38	192	18	96	150	12	63	150	7	39	127	150		
4	172	144	108	86	57	150	43	218	21	109	150	14	72	150	8	45	144	150		

\*A2L pumps : sum up the 2 nozzles / A2L-Pumpen : Summe der zwei Düsen  
pompe A2L : somme des 2 gicleurs / Per le pompe A2L aggiungere n. 2 ugelli

One pipe siphon feed system  
Einstranginstallation - Tank höher als Pumpe  
Installation monotubo en charge  
Impianti monotubo a sifone

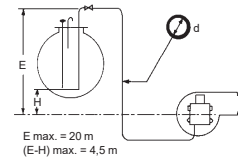

#### Two-pipe system

Pump/Pumpe Pompe/Pompa Q** (l/h)	35/45				55				65				75				95			
	H (m)	d (mm)																		
0	2	15	50	124	11	38	96	150	7	27	71	150	20	54	116	150	16	46	100	150
0,5	2	16	56	138	12	42	107	150	8	31	79	150	23	61	130	150	19	52	112	150
1	2	18	61	150	13	47	118	150	9	34	88	150	26	68	144	150	21	57	124	150
2	3	22	73	150	16	56	141	150	11	41	105	150	31	81	150	150	26	69	148	150
3	4	26	85	150	19	66	150	150	13	48	122	150	36	94	150	150	31	81	150	150
4	4	30	97	150	22	75	150	150	16	55	139	150	42	108	150	150	35	92	150	150

\*\*Q = pump capacity @ 0 bar / Pumpenleistung bei 0 bar  
capacité de l'engrenage à 0 bar/portata della pompa a 0 bar.

Two pipe siphon feed system  
Zweistranginstallation - Tank höher als Pumpe  
Installation bitubo en charge  
Impianti bitubo a sifone

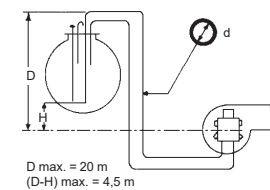

### 7.1.1.2 Underlying tank

#### 1-pipe system

With an underlying tank a 1-pipe-system is not recommended

#### Two-pipe system

Pump/Pumpe Pompe/Pompa Q** (l/h)	35/45 60				55 77				65 102				75 130				95 150			
	H (m)		d (mm)		H (m)		d (mm)		H (m)		d (mm)		H (m)		d (mm)		H (m)		d (mm)	
0	15	50	124	150	11	38	96	150	7	27	71	150	20	54	116	150	16	46	100	150
0,5	13	44	109	150	9	33	84	150	6	24	62	132	17	48	103	150	14	40	88	150
1	11	38	95	150	8	29	73	150	4	20	54	115	15	41	89	150	12	34	76	144
2	7	26	66	138	5	19	51	107	2	13	37	80	9	28	61	116	7	23	52	100
3	3	14	37	79		10	28	60		6	20	44	4	14	33	65		11	28	56
4			8	19			5	14				9			6	14			4	11

The suction line tables consist of theoretically calculated values where the pipe dimensions and oil velocity have been matched so that tur-bulences will not occur. Such tur-bulences will result in increased pressure losses and in acoustic noise in the pipe system. In addition to drawn copper piping a pipe system usually comprises 4 elbows, a non-return valve, a cut-off valve and an external oil filter.

The sum of these individual resi-stances is so insignificant that they can be disregarded. The tables do not include any lengths exceeding 100 m as experience shows that longer lengths are not needed.

The tables apply to a standard fuel oil of normal commercial quality according to current standards. On commis- sioning with an empty tube system the oil pump should not be run without oil for more than 5 min. (a condition is that the pump is being lubricated during operation).

The tables state the total suction line length in metres at a nozzle capacity of 9,5 Gph. Max. permissible pressure at the suction and pressure side is 2,0 bar.

Two pipe lift system  
Zweistranginstallation - Tank tiefer als Pumpe  
Installation bitube en aspiration  
Impianti bitubo in aspirazione

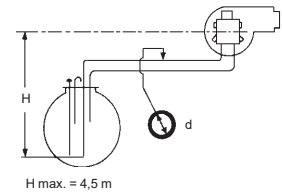

### 7.1.3 Check oil line seals

Once the burner has been installed and commissioned, the seals of the various coupling elements should be checked.

When a leak is detected, it is usually sufficient to tighten the coupling element that is leaking.

**!** Use caution when operating the burner, surfaces may be hot.

**!** When servicing oil bearing components, check for oil leakage when the burner is commissioned after servicing.

### 7.1.2 Replacement of pump filter

#### Removal and installation

1. Close the oil supply to the burner
2. Loosen the pump cover's screws.
3. Remove the filter and gasket
4. Mount new gasket and filter
5. Refit the cover
6. Open the oil supply
7. Start the burner and check seals and combustion

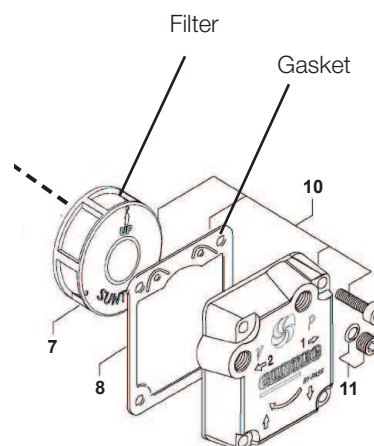

#### Note:

- \* When servicing/replacing components that affect combustion, an analysis and soot test shall be carried out on the installation.

## 7.1.4 Replacing the solenoid valve (pump)

### Removal and installation

1. Make sure the power to the burner is switched off

**!** If the burner is directly connected, ensure that all components on the burner are without power.

2. Disconnect the solenoid valves' electrical cables
3. Loosen the nut holding the magnet terminal
4. Loosen the screws securing the valve's mounting plate
5. Remove the valve
6. Check to ensure the correct valve is in place. NC
7. Install the new valve and refit the other parts in the reverse order.
8. Check functionality

## 7.1.5 Replacing the gasket seal (pump)

### Removal and installation

1. Disconnect hoses, oil pipes, and electrical cables
2. Loosen the pump (screw J)
3. Loosen the gasket seal's locking rings
4. Remove the old gasket seal (2)
5. Install the new gasket seal
6. Connect hoses, oil pipes, and electrical cables
7. Test run and check seals

1. Pressure regulator kit 5 - 25 bars
2. Shaft seal kit (lip seal + protective cone)
3. By-pass plug
4. G 1/4 gasket
5. G 1/4 steel plug
6. G 1/4 plastic plug
7. Filter
8. Cover gasket
9. Cover gaskets + filter
10. "Cover + cover gasket + filter" kit
11. Pressure gauge port or vacuum gauge port screw, O-ring
- 12.
13. Coil
14. Tube assy

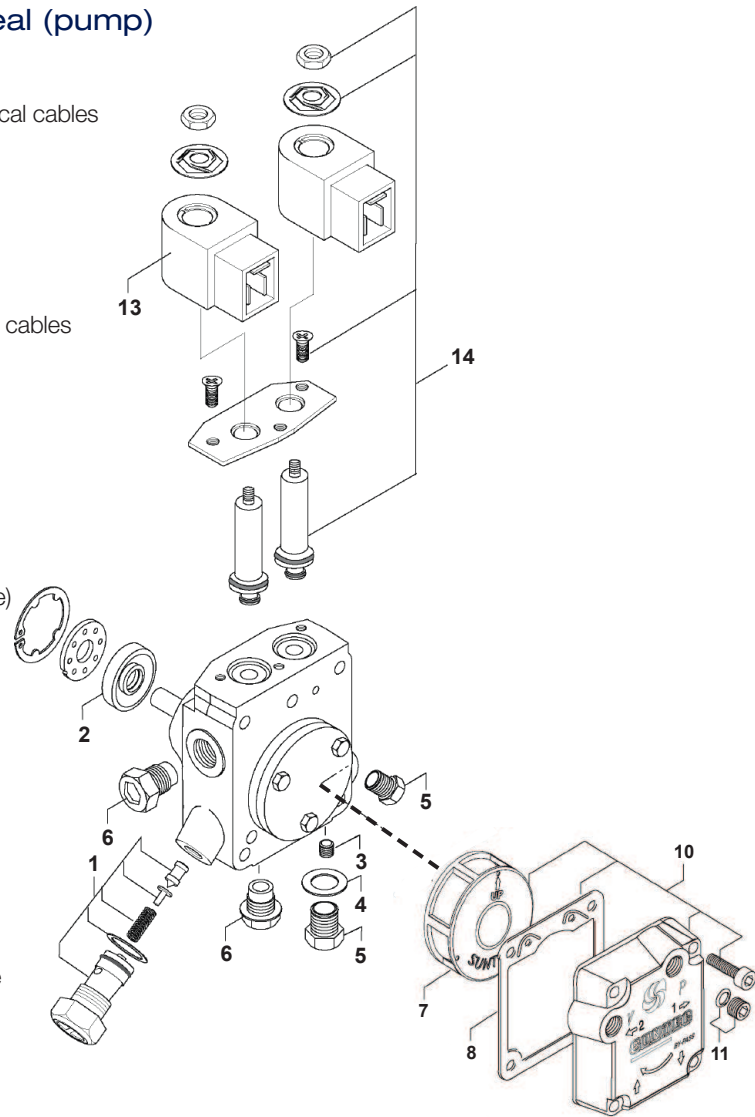

## 8. Replacement of electrical components

1. Switch off the mains power.



If the burner is directly connected, ensure that all components on the burner are without power.

2. Note the connection of the existing component.
3. Remove the existing component.
4. Install the new component using the same wiring as the existing component or the specified alternative arrangement.
5. Turn on the mains power.
6. Check the function of the new component.
7. Start the burner. Check combustion.\*

### Note:

- \* When servicing/replacing components that affect combustion, an analysis and soot test shall be carried out on the installation.



# 9. Oil burner control

## 9.1 Wiring diagram

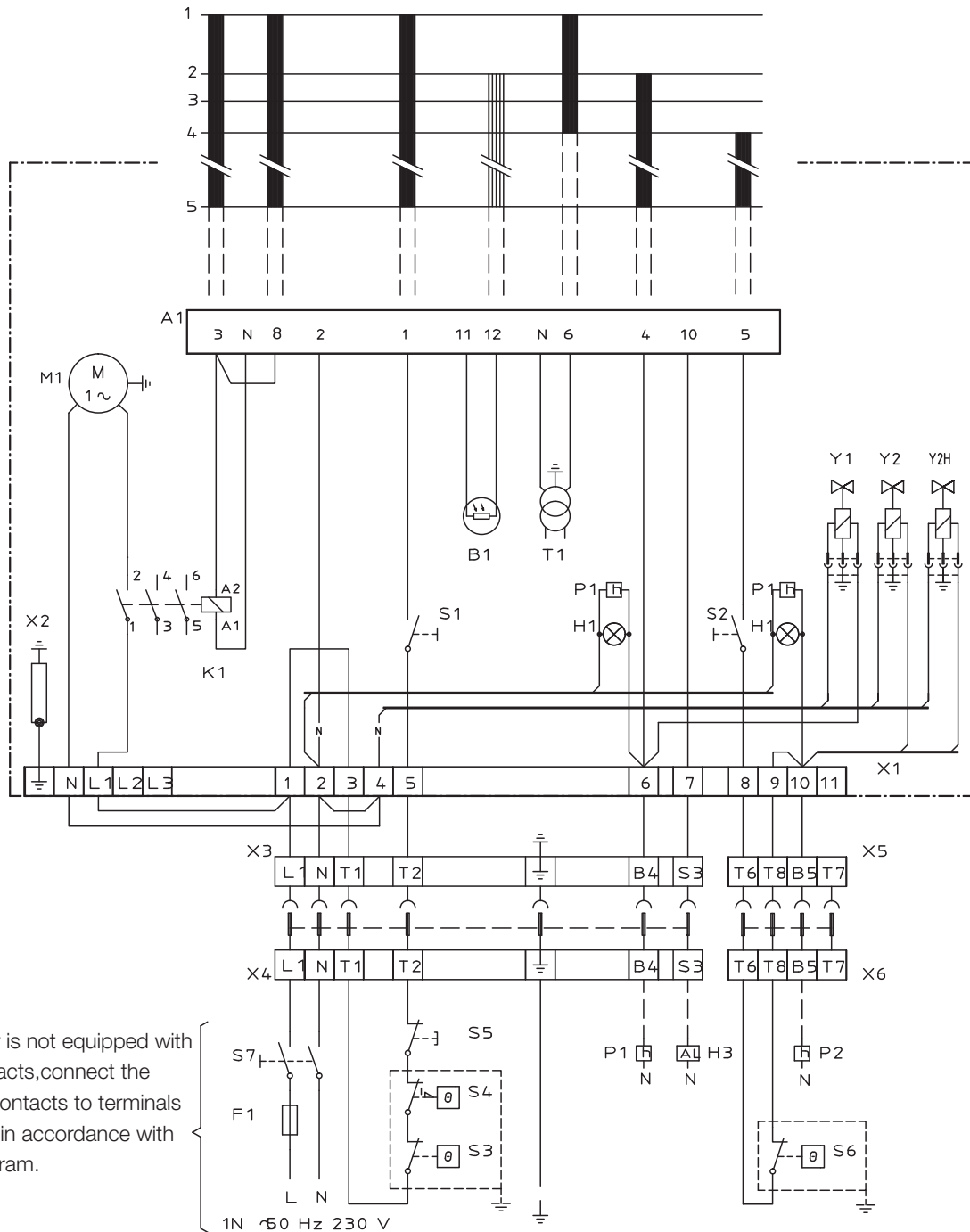

## 9.2 List of components

A1	Oil burner control	X1	Connection terminal board
B1	Flame detector	X2	Earth terminal
F1	Fuse	X3	Plug-in contact "Euro", burner
H1	Lamp, low capacity	X4	Plug-in contact "Euro", boiler
H3	Lamp, lock-out signal 230 V	X5	Plug-in contact "Euro", high/low burner
K1	Thermal overload protection	X6	Plug-in contact "Euro", high/low boiler
M1	Burner motor	Y1	Solenoid valve 1
P1	Time meter, low capacity (optional)	Y2	Solenoid valve 2
P2	Time meter, high capacity (optional)	Y2HSolenoid valve, Hydraulic piston (Only 2-stage burners with 1 nozzle.)	
S1	Operating switch		
S2	Operating switch, high/low capacity		
S3	Control thermostat		
S4	Temperature limiter		
S5	Micro switch for hinged door		
S6	Control thermostat, high/low capacity		
S7	Main switch		
T1	Ignition transformer		

Mains connection and fuse in  
accordance with local regulations

## 9.2.1 Function LOA

- 1 **1. Switch on operating switch and twin thermostat**  
The burner motor starts, an ignition spark is formed, the prepurge goes on till the prepurge period expires and the solenoid valve 1 opens (2)
2. **Solenoid valve 1 opens**  
Oil mist is formed and ignited. The photocell indicates a flame.
3. **The safety time expires**
  - a If no flame is established before this time limit the control cuts out.
  - b If for some reasons the flame disappears after this time limit, the burner will make an attempt to re-start.
- 4 **Full load thermostat ON**
  - 1) The ignition spark goes out 15 s. after flame indication (LOA24.171...).
  - 2) The ignition spark goes out 2 s. after flame indication when the ignition transformer is connected to terminal 7 (LOA24.173...). The burner is in operating position and can now change between high and low capacity.
- 4-5 **Operating position**  
If the burner operation is interrupted by means of the main switch or the thermostat, a new start takes place when the conditions in accordance with point 1 are fulfilled.
 

**The oil burner control cuts out**  
A red lamp in the control is lit. Press the reset button and the burner re-starts.

**Post-ignition**  
(2) If a post-ignition of 15 s is wanted, move the ignition transformer from terminal 7 to terminal 6 (LOA24.173...).

Technical data oil burner control	LOA
Pre-ignition time:	13 s
Pre-purge time:	13 s
(1) Post-ignition time:	15 s
(2) Post-ignition time:	2 s
Safety lock-out time:	10 s
Reset time after lockout:	≈ 50 s
Reaction time on flame failure:	< 1 s
Ambient temperature:	-20 - +60°C
Min. current with flame established:	65 μA
Max. photo current at start:	5 μA dc

# 10. Fault Location

## 10.1 Burner will not start

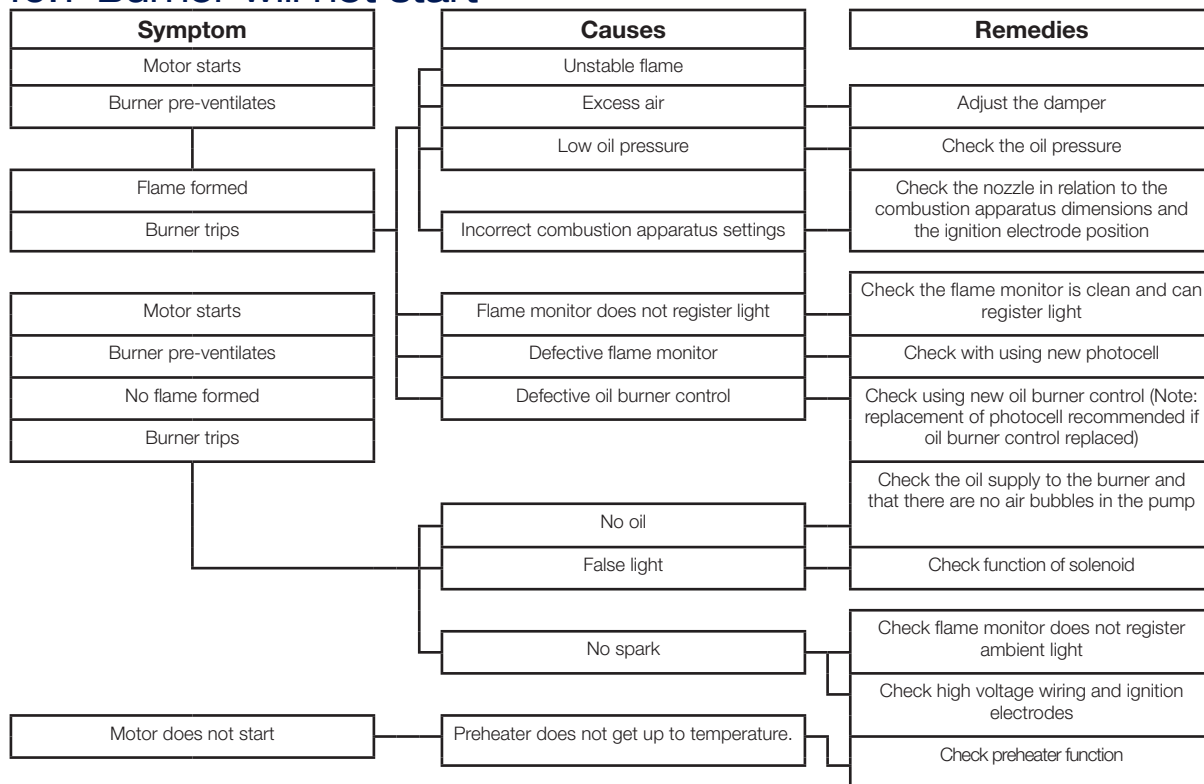

## 10.2 Burner will not start after normal use

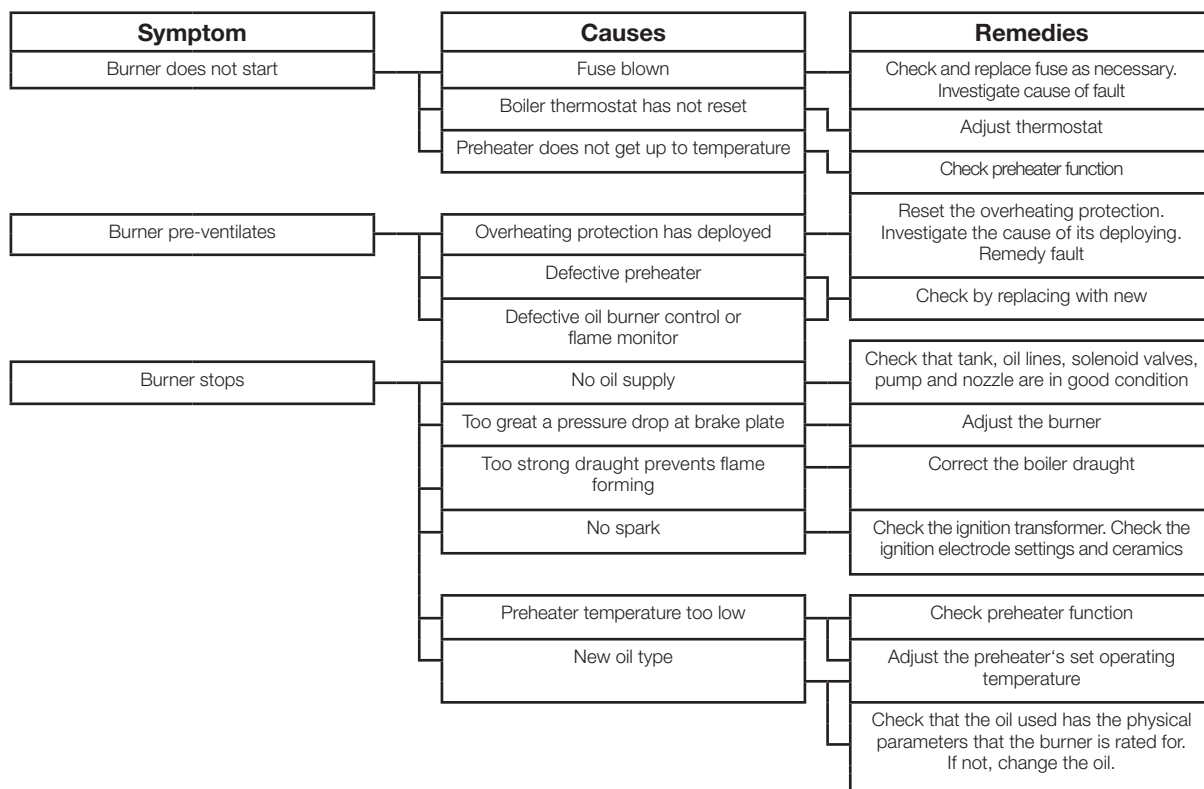

## 10.3 Delayed ignition

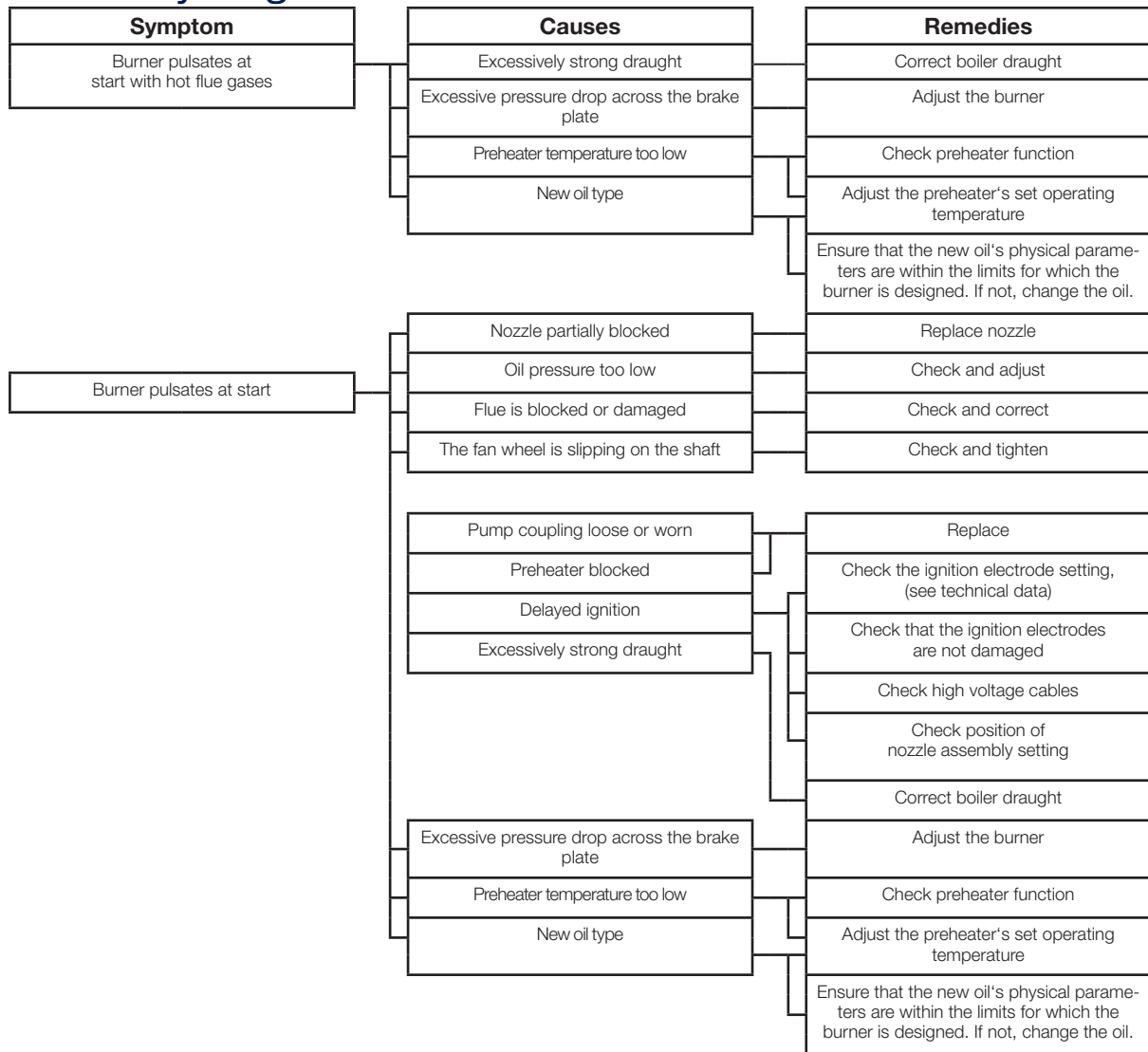

## 10.4 Noise in pump

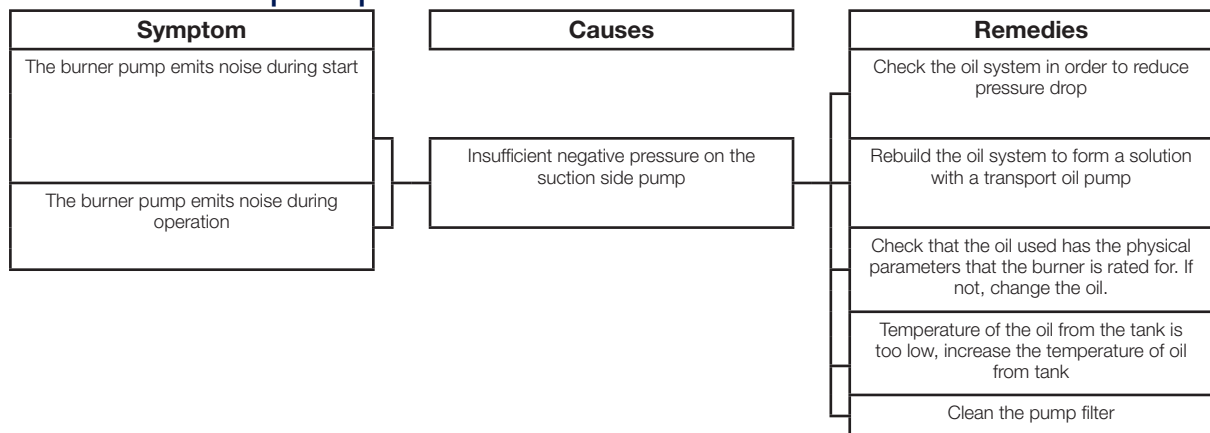

## 10.5 Pump pressure

Symptom	Causes	Remedies
The burner pump can not build up pressure	No oil	Check that there is oil and that it reaches the pump
	Oil viscosity too low	Check that the oil reaching the pump has the physical parameters that the pump can handle. Change the oil or the pump's oil parameters
	Pump worn	Replace the pump
	Pump run using impure oil that has worn the pump out prematurely	Replace pump and install self-cleaning filter in the oil system
	Blocked pump filter	Check, clean pump filter

# 11. Log of flue gas analysis

Owner	Adresss	Tel. no:
Installation		Tel. no:

## Boiler

Type	Make	Power kW
------	------	----------

## Bentone Burner

Type	Model	Serial no.	Fuel
------	-------	------------	------

	Step 1	Step 2	Step 3
Draught in fireplace			
Fan Press mbar			
Filter smoke number			
CO <sub>2</sub>			
O <sub>2</sub>			
NOx			
CO			
Flue gas temp. °C			
Setting brake disc			
Setting Air damper			
Pump pressure bar			
Nozzle			

Test performed / 20	Address
Test performed by:	Postal address
Company name:	Tel. no:

# 12. Oil burners maintenance instructions

## General information

Keep the boiler room clean. Ensure that the boiler room has permanent fresh air intake. Switch off before dismantling the oil burner.

At hinged mounting, make sure that an automatic safety switch is fitted, so that the burner cannot start when the swing door is open.

Don't use the oil fired boiler to burn paper or rubbish, unless the boiler is especially fitted with a hinged door to make this possible.

Don't fill tank while burner is working.

## Starting precautions

Make sure that the oil tank is not empty

Make sure that the valves on oil and water supply pipes are open.

Make sure that the boiler flue damper is open.

Make sure that the boiler thermostat is set at the correct temperature.

Switch on the current. Most relay systems have a delayed action so that the burner will not start for perhaps 20 seconds.

With heavy oil the delay will be longer as the burner will not start until the oil in the preheater reaches the required temperature.

## If the burner will not start

Press the reset button on the relay. Check that the thermostats are correctly adjusted.

Don't forget the room thermostat, check that any fuses are intact and main switch is on.

## If the burner starts but does not ignite

Make an attempt to start the burner.

Never make close repeated start attempts.

Don't restart the burner until the boiler is free from oil gases.

If the burner still does not ignite send for the service engineer.

## When switching off during summer

Always use the main switch to cut out the burner even when adjusting the burner or cutting off the heating for a short time. For longer periods of shut down, close all valves and the oil supply stopcock.

Clean the filter and nozzle by washing in petrol or paraffin.

Make sure the filter medium is not damaged or defective.

Protect electrical gear from damp.

## Warning

Never stand too near or put your face to the inspection or fire door, when the burner is about to start.

Never use a naked flame to ignite oil if the electrical ignition fails.

Always wait for about 10 minutes for the unburnt gases to disperse before restarting the oil burner if it has failed to ignite previously.

## Installed by:

.....

Tel: .....









