



Installation and Maintenance Manual

BG 650 M

LME22.233C2

MB-VEF 415-420

Translation of the original instructions.

Keep for future use.

Read carefully before use.



MADE IN SWEDEN

**-sv****1. Manualer på övriga språk**

2. [www.bentone.com\nedladdning](http://www.bentone.com/nedladdning) eller scanna QR-koden.

3. Skriv in brännarens artikelnummer som finns på din typskylt (se bild) och välj ditt språk.

Detaljerad ecodesign information kan laddas ner på:
www.bentone.com/ecodesign.

-fr**1. Manuels dans d'autres langues**

2. www.bentone.com/download ou scannez le code QR.

3. Saisir le numéro d'article du brûleur sur votre plaque signalétique (consultez l'illustration) et sélectionnez la langue.

Des informations détaillées sur l'ecodesign peuvent être téléchargées à l'adresse:
www.bentone.com/ecodesign.

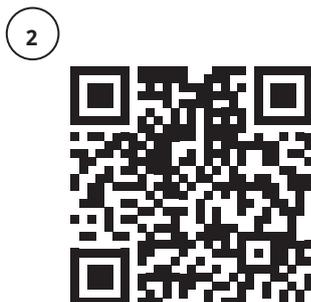
**-en****1. Manuals in other languages**

2. www.bentone.com/download or scan QR-code.

3. Enter the burner's article number on your data plate (see picture) and select language.

Detailed ecodesign information can be downloaded at:
www.bentone.com/ecodesign.

-de**1. Gebrauchsanweisungen in anderen Sprachen**

2. www.bentone.com/download oder scannen Sie den QR-Code.

3. Geben Sie die Artikelnummer des Brenners auf Ihrem Typenschild ein, (siehe Bild) und wählen Sie die Sprache aus.

Detaillierte Informationen zum Ecodesign können unter
www.bentone.com/ecodesign heruntergeladen werden.

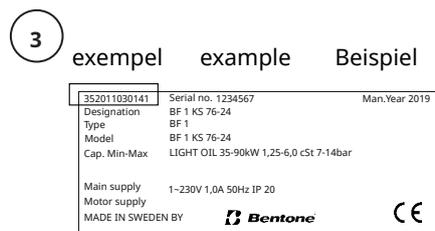

exempel example Beispiel

1. Manualer på andre sprog

2. www.bentone.com/download eller scann QR-koden.

3. Indtast brænderens artikelnummer, der findes på typeskiltet (se billede), og vælg dit sprog.

Detaljerede oplysninger om ecodesign kan downloades på:
www.bentone.com/ecodesign.

Table of contents

1. General Information.....	5	6. Settings	23
1.1 Delivery inspection.....	5	6.1 Setting the combustion assembly	23
1.2 Safety	5	6.2 Startup.....	23
1.3 What to do if you smell gas.....	6	6.3 Control of combustion	23
2. Technical data.....	7	6.4 Setting the air pressure switch	24
2.1 Dimensions BG 650 M	7	6.5 Setting the gas pressure switch, min.....	25
2.3 Gas categories, approved gases.....	8	6.6 Setting Damper motor, Modulating operation	26
2.2 Capacity range	8	7. Gas valve, MultiBloc VEF 415-425 B01	27
2.4 Technical specification	9	7.2 Mounting instruction - impulse lines P_L , P_F and P_{Bf}	28
2.5 Working field	9	7.3 Adjustment possibilities.....	28
2.6 Components.....	10	7.1 Technical data	28
2.7 Skeleton diagrams	12	8. Service	30
3. Electric equipment.....	13	8.1 Burner Service Schedule, Gas	30
3.1 Safety system	13	8.2 Component replacement intervals.....	30
3.2 Wiring diagram.....	13	8.3 Combustion device	31
3.3 Function LME	14	8.4 Air damper.....	32
3.4 Control program at faults; fault mode indicator LME	15	8.5 Replacement, Damper motor air.....	33
4. Installation.....	17	8.6 Fan	34
4.1 General instructions	17	8.7 Vibrations.....	35
4.2 Instructions	17	8.8 Control of flame monitoring and ionization current	36
4.3 Inspection and maintenance.....	17	8.9 Replacement of electrical components.....	38
4.4 Preparation for assembly	17	9. Handing over of the installation	39
4.5 Gas supply	17	10. Troubleshooting.....	40
4.6 Electric connection	17	11. Service- and inspection protocol	42
4.7 Handling and lifting instruction	18		
5. Mounting	19		
5.1 Gas nozzle.....	20		
5.2 De-aerating.....	21		
5.3 Leakage control.....	21		
5.4 Calculation of gas flow	22		

1. General Information

The burner may only be used for its intended purpose in accordance with the product's technical data.

We reserve the right to make design changes and cannot be held liable for any misprints or typographical errors.

Modifying the design or using accessories or components that have not been approved by CTC in writing is strictly prohibited.

This Installation and Maintenance manual:

- is to be regarded as part of the burner and must always be kept near the installation site.
- must be read prior to installation.
- is intended for use by authorised personnel.

1.1 Delivery inspection

- Make sure everything is delivered and the goods have not been damaged during transit. Transport damage should be reported to the shipping company.
- If something is wrong with a delivery, report it to the supplier.

1.2 Safety

- before installation:

- Installation and work on the burner and associated system components may only be carried out by persons who have undergone relevant training.
- The product is packaged to prevent damage from occurring when handled – Handle the product with care! Lifting equipment must be used to lift larger packages.
- The products must be transported/stored on a level surface in a dry environment, max. 80% relative humidity, no condensation. Temperature -20 to +60 °C.



- installation:

- The burner must be installed in accordance with local regulations for fire safety, electrical safety, and fuel distribution.
- The premises must comply with local regulations pertaining to use of the burner and must have adequate air supply.
- The installation site must be free of chemicals.
- Fire extinguisher with Class BE recommended.
- Make sure when installing the burner that there is enough space to service the burner.
- The electrical installation must be professionally carried out in accordance with current mains electricity regulations and in a professional manner.
- Make sure that the burner is suitable for the application (see Technical Data).
- All components must be installed without being bent, twisted or subjected to mechanical or thermal forces that affect components.

- Care must be taken by the installer to ensure that no electrical cables or fuel lines are pinched or otherwise damaged during installation or service.
- Sharp edges can occur on, for example: flame tube, fan wheel and air damper.
- The gas outlet from the pressure regulator must be configured in accordance with applicable regulations and lead to a safe area.

- before first start:

- The burner must not be put into operation without proper safety and protection devices.
- Permitted ambient temperature during operation -10 to +60 °C. Max. 80% relative humidity, no condensation.
- The surface temperature of the burner's components may exceed 60 °C.
- Handle with caution – the burner has moving parts, and there is risk of crushing injuries.
- Seal inspections must be performed during installation and servicing to prevent leakage.
- Fitting and installation work has been completed and approved.
- Electrical installation has been correctly performed.
- Flue gas ducts and combustion air ducts are not blocked.
- All actuators and control and safety devices are in working order and correctly set.
- If the boiler is equipped with an access hatch, this must be equipped with a hatch opening switch connected to the burner's safety system.
- When in operation, the burner's noise level can exceed 85 dBA – use hearing protection!

- operation:

- Carry out all stipulated settings, service and inspection work within the set time.

1.3 What to do if you smell gas

- Turn off the fuel supply.
- Turn off the device and remove the boiler from operation.
- Open windows and doors.
- Prevent open flames or sparking, e.g. do not turn lights on or off, do not use any electrical appliances or mobile phones.
- Evacuate the building.
- Notify the installer or gas supplier of the problem so that it can be rectified.



2. Technical data

The burner is intended for:

- Operation in installations according to EN 303 and EN 676.

Fuels:

- Natural gas H, E, L, LL.
- LPG, Butane and Propane.

2.1 Dimensions BG 650 M

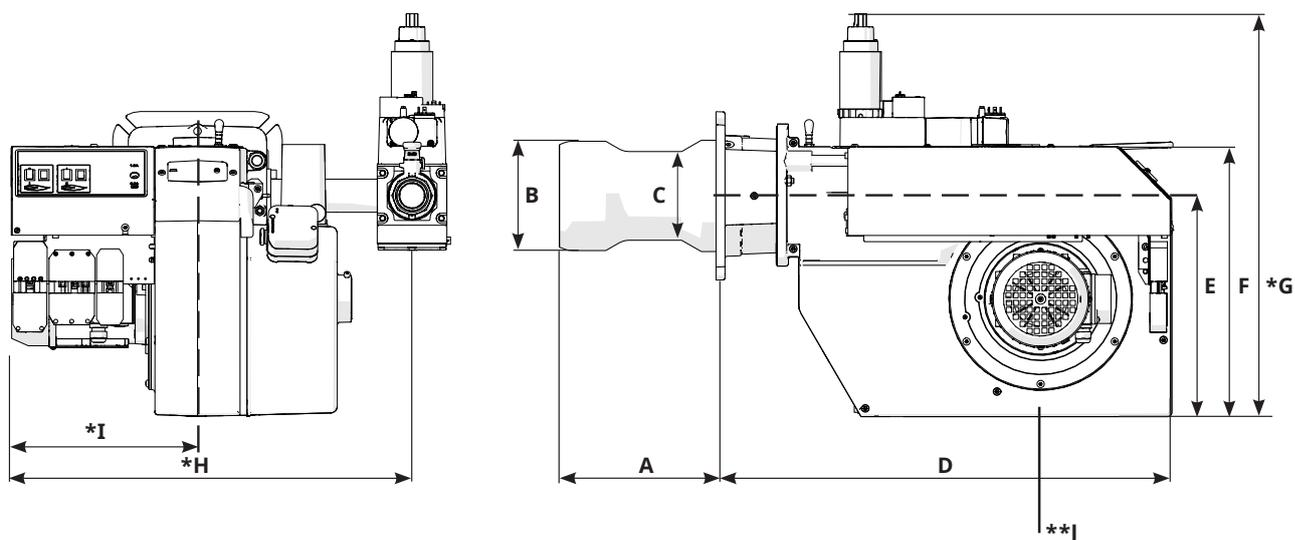

Length of flame tube	Flame tube measure A	Flame tube measure B	Flame tube measure C
316	286	ø184	ø162
416	386	ø184	ø162

D	E	F	G	H	I	J
660	320	400	*590	*743	*343	**200

* The above dimensions are max. measurements. Depending on the components used, the measurements may vary.

** Min. recommended distance to floor.

2.1.1 Measurements for connection to the boiler

K	L	M
14	(ø210) ø255-290	ø (170)190

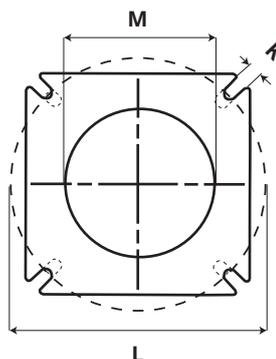

2.2 Capacity range

Capacity kW	Gas quantity at min. power Nm ³ /h	Gas quantity at max. power Nm ³ /h	Max. connection pressure mbar	Nominal connection pressure mbar
650 / 650i				
G20 200 - 1125	21.2	119.0	360	See data plate.
G25 200 - 1125	24.6	138.4	360	
G30 200 - 1125	6.2	34.9	360	
G31 200 - 1125	8.2	46.0	360	
Biogas 200-950	33.3	158.3	360	45

160302-282-2

Gas quantity and capacity vary according to grade of gas and connection pressure.

2.3 Gas categories, approved gases

Only dry gas is permitted for use.

Category	Country of destination	Supply pressure
II _{2R3R}	AT, BE, BG, CH, CY, CZ, DE, DK, EE, ES, FI, FR, GB, GR, HR, HU, IE, IS, IT, LT, LU, LV, MK, MT, NL, NO, PL, PT, RO, RS, SE, SI, SK, TR	40 mbar
II _{2H3B/P}	AT, CH, CY, DK, FI, LT, RO, SE, SK	40 mbar
II _{2H3P}	GB, IE	40 mbar
II _{2L3B/P}	RO	40 mbar
II _{2E3B/P}	PL	40 mbar
I _{2E(R)B}	BE	40 mbar
I _{3P}	BE	40 mbar
II _{2EK3B/P}	NL	40 mbar

160302-236-4

2.4 Technical specification

BG 650 M	
Main supply, Operation ^{1) 2)}	230V, 1~, 0.6A, 50Hz, IP20
Main supply, Motor ¹⁾	230/400V, 5.9/3.4A
Max fuse rating, Motor	6.3A
Max fuse rating, Operating	10A
NO _x -class	2 - G20, G25, G31, 3 - G30
Sound power (dBA) L _{WA}	91dBA

¹⁾ Max operating current, see data plate.

²⁾ Motor excluded.

Measurements according to EN 15036-1:2006

Alt.1 The noise level of the burner can be reduced by equipping the burner with silencer. Installation must be done so it does not prevent air supply to the burner.

Alt.2 The burner's noise level can be reduced by connecting the burner's air intake to the air duct that opens into an appropriate location. Installation must be done so it does not prevent air supply to the burner.

2.5 Working field

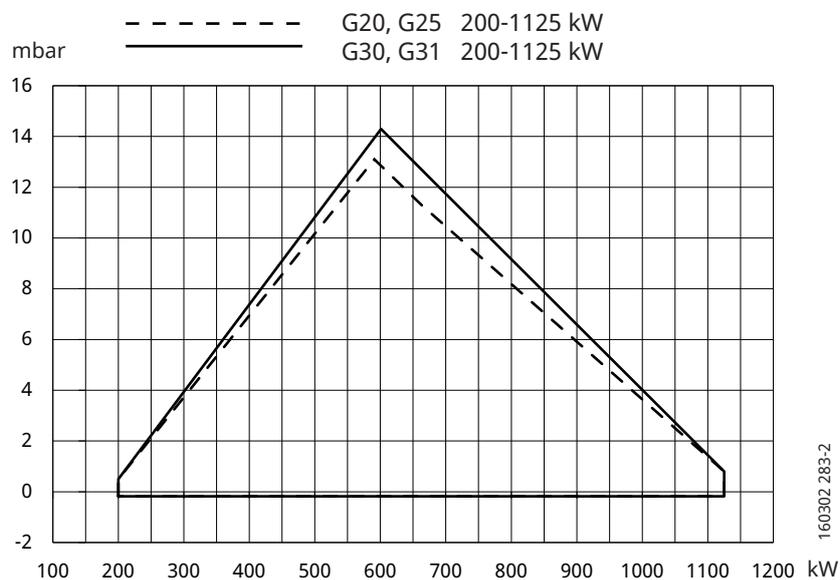

! Do not exceed working field.

2.6 Components

- | | | |
|-----------------------------|---|-------------------------------------|
| 1. Flame tube | 10. Motor | 18. Change-over switch, man-auto |
| 2. Fixing flange | 11. Connection, gas | 19. Operating lamp |
| 3. Guides | 12. Transformer | 20. Power switch 0-I |
| 4. Fan wheel | 13. Air damper | 21. Contactor + Overload protection |
| 5. Gas pressure switch, min | 14. Damper motor | 22. Burner control |
| 6. Brake plate | 15. Air pressure switch | 23. Gas fittings |
| 7. Ignition electrode | 16. Fuse holder | 24. Gas valve (MultiBloc) |
| 8. Nozzle | 17. Change-over switch, increase-decrease | |
| 9. Ionisation electrode | | |

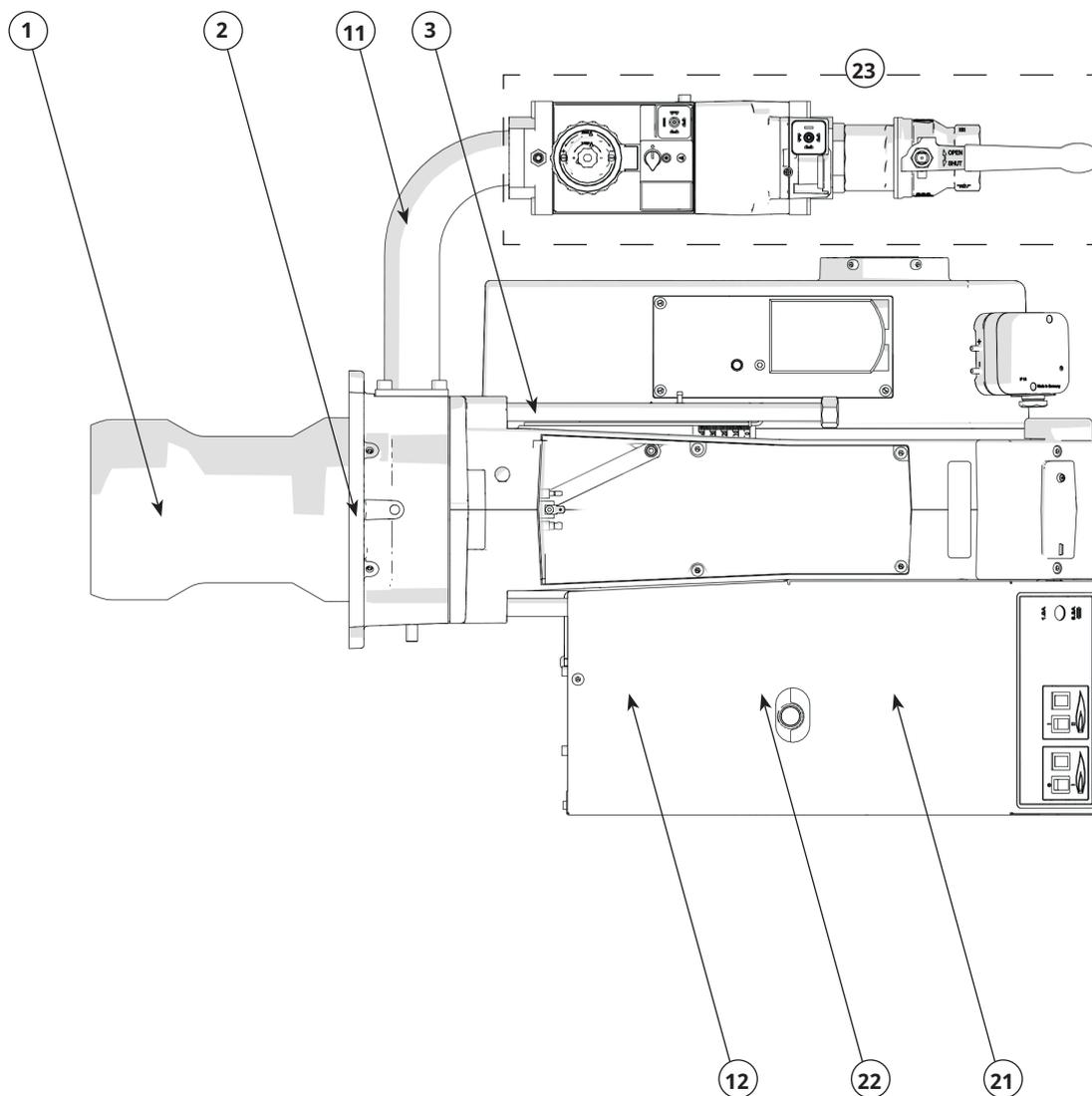

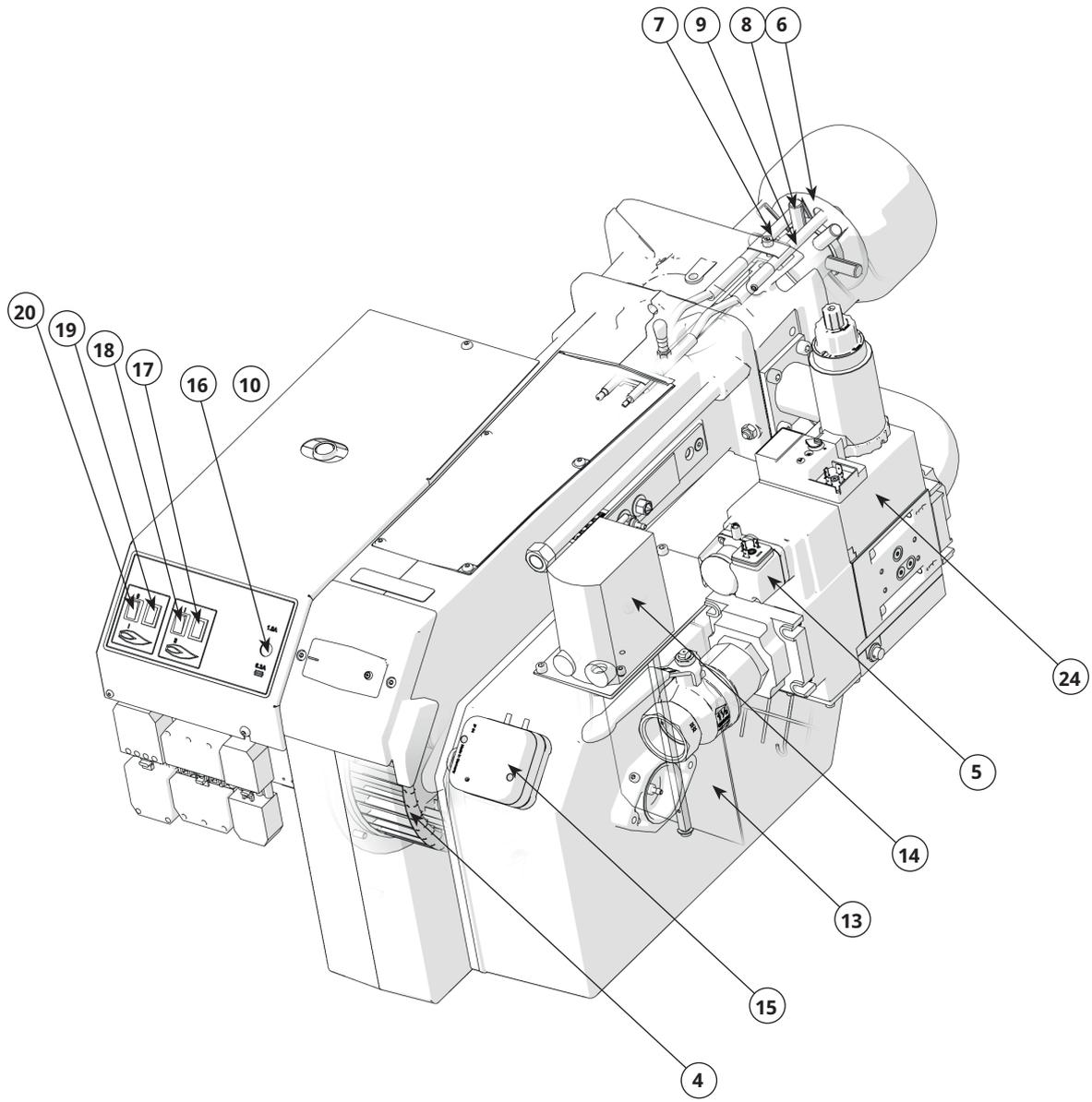

2.7 Skeleton diagrams

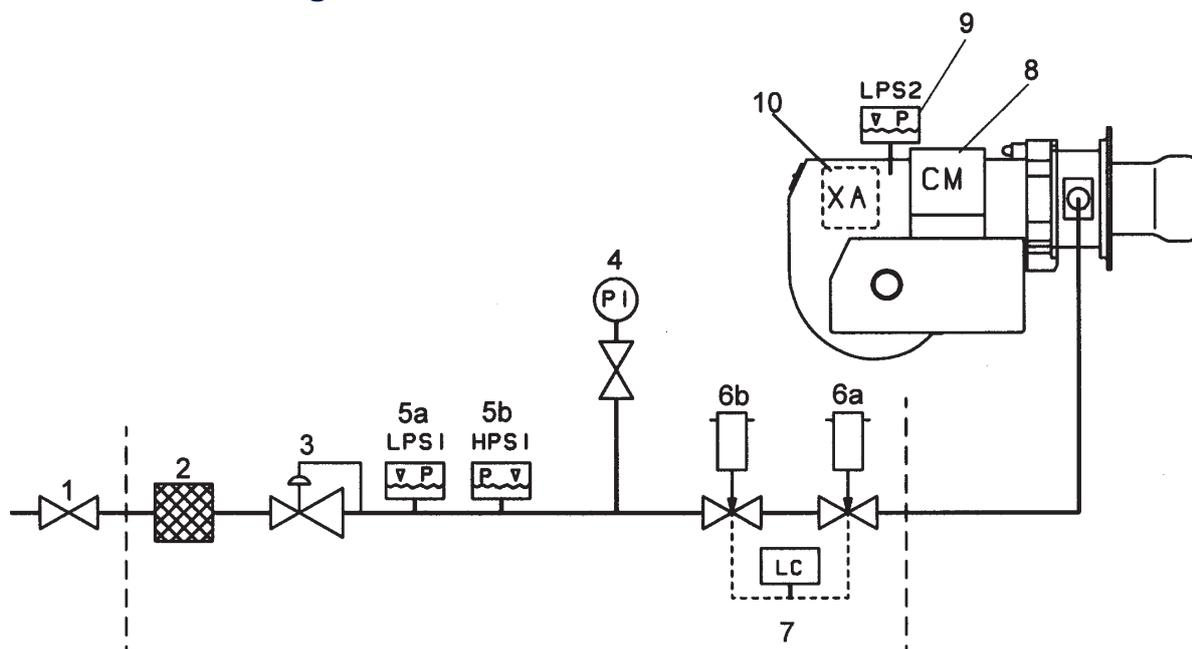

1. Ball valve
2. Filter
3. Pressure regulator
4. Pressure gauge with shut-off cock
- 5a. Gas pressure switch, min
- 5b. Gas pressure switch, max
- 6a. Main valve, 2-stage. In modulating operation, this valve is equipped with controls for variable opening.
- 6b. Safety valve
- 7.¹⁾ Leakage control
9. Air pressure switch
10. Burner control

Pos. 5b, 7: Components not required according to EN 676.

¹⁾ Required over 1200 kW according to EN 676.

3.2.1 Components

A1	Burner control	S1	Operating switch	T1	Ignition transformer
A2	Power control	S3	Control thermostat	X1	Connection terminal board
B1	Ionization electrode	S4	Temperature limiter	X2	Earth terminal
F1	Operating fuse	S5	Safety switch for hinged door	X3	Plug-in contact, burner
F2	Operation fuse	S7	Main switch	X4	Plug-in contact, boiler
F3	Operation fuse	S8	Air pressure switch	X7	Plug-in contact, 3-phase, burner
H1	Operating lamp	S9	Gas pressure switch, min	X8	Plug-in contact, 3-phase, boiler
K1	Contactor + Overload protection	S11	Change-over switch, Man-Auto	X15	Plug-in contact, power controller, burner
M1	Motor	S12	Change-over switch, Increase- Decrease	X16	Plug-in contact, power controller
M2	Damper motor	S15	Control thermostat, 3-pole (only for 2-stage sliding)	Y1	Solenoid valve 1
Q1	Signal amplifier AGQ (accessory)	S20	Main switch 1-phase	Y3	Solenoid valve 3
R1	UV-detector (accessory)				

3.3 Function LME

- Operating switch ON-Thermostat ON-Gas pressure switch ON-Air damper closed.**
Check that the air pressure switch does not indicate fan pressure, then the motor starts.
- Damper motor opens.**
The damper motor opens the damper to the maximum load position. Check that the air pressure switch indicates sufficient fan pressure.
- Damper motor closes.**
The damper motor closes to the minimum load position, then the ignition spark is produced.
- Main and safety valves open.**
The gas ignites and the ionisation electrode indicates flame.
- The safety time ends.**
Ignition spark and safety time cease. If the spark is missing or it disappears after this time limit, the gas burner control is blocked.
- Operating position.**
The burner is in operating mode and can now switch to the capacity controlled by the controller.
- Stop.**
The burner operation can be stopped with the operating switch or the thermostat.

 Mains connection and fuse in accordance with local regulations.

If the gas burner control is blocked

The red light in the gas burner control comes on. The burner is restarted by pressing the reset button.

3.2.2 Technical data

	LME22.232C2E
Preignition time	3 s
Prepurge time	20 s
Postignition time	2.5 s
Safety lockout time	< 3 s
Reset time after lockout	< 1 s
Reaction time on flame failure	< 1 s
Min. ionisation current at flame	5 μ A
Max. ionisation current	20 μ A

160303-325

3.4 Control program at faults; fault mode indicator LME

3.4.1 Colour codes

Table colour codes for multi-coloured signal light (LED)		
Status	Colour codes	Colours
Waiting period «tw», other waiting periods	○.....	Off
Ignition phase, ignition controlled	●○○●○○●○○●	Blinking yellow
Normal operation	□.....	Green
Operation, poor flame signal	□○□○□○□○□○	Blinking green
Illegal flame signal during start-up	□▲□▲□▲□▲□▲	Green-Red
Undervoltage	●▲●▲●▲●▲●▲	Yellow-Red
Fault, alarm	▲.....	Red
Blinking code for fault codes	▲○▲○▲○▲○	Blinking red
Interface diagnostics	▲▲▲▲▲▲▲▲	Red flicking

.....	Continuous
○	Off
▲	Red
●	Yellow
□	Green

3.4.2 Diagnosing alarm causes

After alarm disconnection, the red alarm signal light is lit continuously. The diagnosing of the alarm cause can be read according to the following sequence:

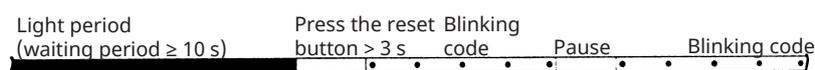

3.4.3 Limiting of starting repetitions

LME 11... has a function with start repetition if the flame is not created at start or disappears during operation.. LME 11... allows max. three repetitions during continuous starting cycle.

3.4.5 Alarm code table

Red blinking code on signal lamp (LED)	Possible causes
Blinking 2 x ..	No flame creation at End of "TSA" <ul style="list-style-type: none"> - defective or fouled flame monitoring. - defective or fouled fuel valves. - poor burner setting. - defective firing device.
Blinking 3 x ...	"LP" defective <ul style="list-style-type: none"> - No air pressure switch signal after "t10". - "LP" is welded in open position.
Blinking 4 x	Illegal flame signal during start-up.
Blinking 5 x	Time out "LP" <ul style="list-style-type: none"> - "LP" is welded in open position.
Blinking 6 x	Free
Blinking 7 x	Too many flame disappearances during operation. <ul style="list-style-type: none"> - poor burner setting. - defective or fouled fuel valves. - defective or fouled flame monitoring.
Blinking 8 x	Free
Blinking 9 x	Free
Blinking 10 x	Connection fault or internal fault, outgoing contacts or other faults.
Blinking 14 x	CPI contact not closed.

During the diagnosing of the alarm cause, the control outputs are voltage-free.

- The burner is disconnected.
- Exception, alarm signal «AL» at board 10.
- Reconnection of the burner happens after resetting only.
- Press the reset button 0.5...3 s.

3.4.4 Interface diagnostics

To change to interface mode, press and hold the reset button longer than 3 s. To go back to the normal position, press and hold the reset button longer than 3 s. If the gas burner control is in the alarm position, it is reset by pressing the reset button 0.5...3 s.

4. Installation

4.1 General instructions

Installation must be carried out in accordance with current regulations and instructions.

The supplier/installer of the facility is obliged to familiarize himself with all regulations so that the installation meets the requirements of the local authorities.

Installation, assembly and settings must be performed to obtain the best possible function. Only gas intended for the gas burner may be used.

4.2 Instructions

It is the installer's responsibility to instruct the user in detail in the functions of the gas burner and the entire system.

4.3 Inspection and maintenance

The system must be maintained at the interval specified in the service schedule. If the burner is in a dirty environment, service should be done at more frequent intervals.

4.4 Preparation for assembly

Check that the burner's dimensions and capacity range match the current boiler. The power information on the type plate refers to the burner model's min. and max. effect.

4.5 Gas supply

In order to obtain good operational safety, it is important that the installation of the gas distribution system is carried out correctly, considering the following:

- Check that the burner is approved for the gas quality of the installation.
- Check that the burner gas components are approved for the specified gas pressure, see type plate.
- Installation must be carried out in accordance with current standards.
- Pipe lines should be assembled so that service can easily be performed on the boiler and burner.
- Pipe lines should be assembled so that any contaminants do not come into contact with the gas components.

4.6 Electric connection

- Before work on the electrical connection, the current must be disconnected so that the installation is isolated.
- Connection must be done in accordance with the applicable regulations.
- Connection must conform to the wiring diagram.



If any electrical connection other than that recommended by CTC is used, there is a risk of property damage and personal injury.

4.7 Handling and lifting instruction



The lifting aid are available as accessories.



5. Mounting

Mount the burner to the boiler using 4 bolts (if new fixing holes need to be drilled, use the fixing flange as a template).

Separate the fixing flange from the fan housing as follows:

1. Remove cover of fan housing (A), disconnect ignition and ionizing cables and the control arm (B) from nozzle assembly.
2. Disconnect the electrical cable to the gas valve.
3. Loosen nuts on both sides of the fixing flange.
4. Loosen end stop (C) for guides.
5. Pull the fixing flange with flame tube, nozzle assembly and gas fitting out of the fan housing.
6. Check that the ignition electrodes are correctly set, see chapter Gas nozzle.
7. Fit the enclosed gasket to the flame tube.
8. Screw the fixing flange and the enclosed gasket onto the boiler, lift the fan housing onto the guides and mount in reverse order.
9. Connect the gas line, connect the supply cable, operating and safety circuits.



Before obtaining access to electrical and fuel line components all supply circuits must be disconnected.

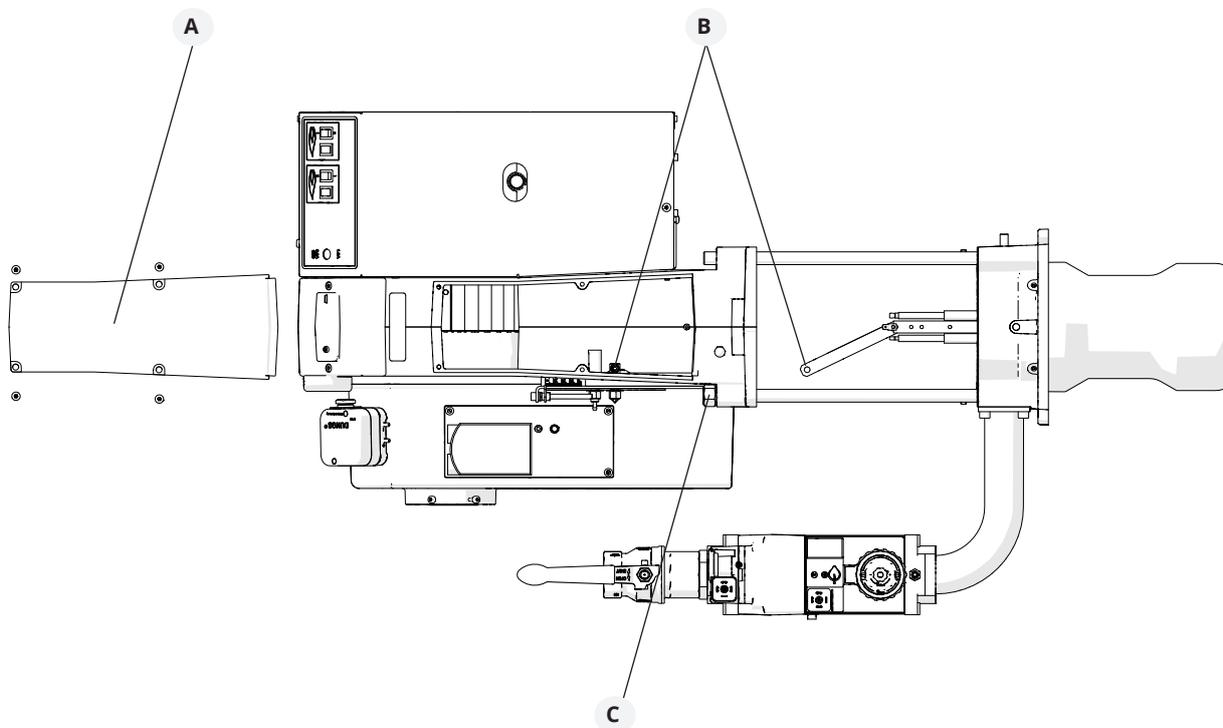

5.1 Gas nozzle

Check that the ignition electrodes are correctly set before mounting on the boiler.

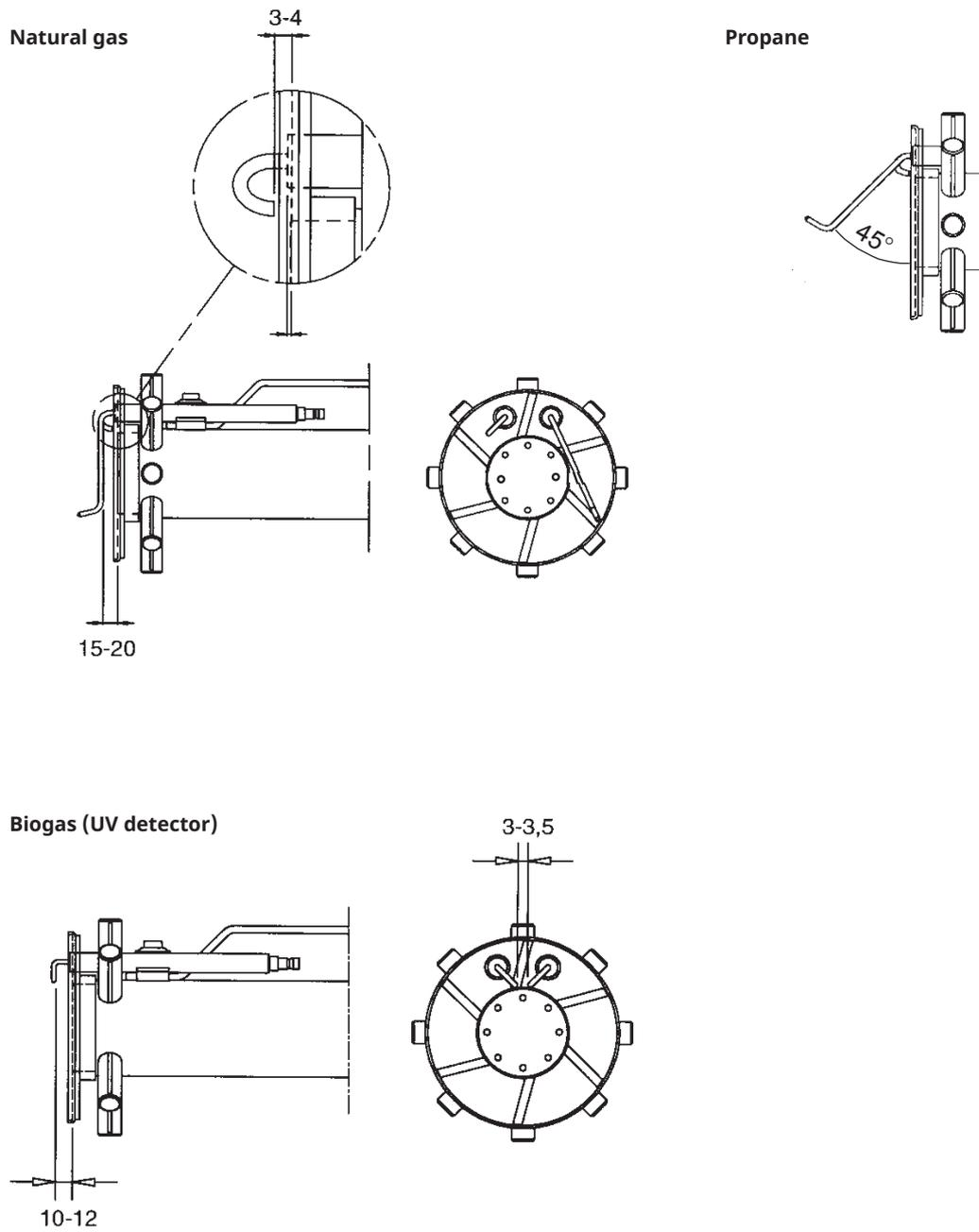

5.2 De-aerating

De-aerating the gas line by closing the tap to the gas connection and unscrewing the screw on the measuring nipple for the connection pressure. Connect a plastic hose, open the tap and drain the gas in a safe place. When the de-aerating is completed, be sure to refit the screw on the measuring nipple.

5.3 Leakage control

When checking for leakage, the solenoid valve must be closed. A pressure gauge is connected to the measuring nipple "Pa", see picture. The test pressure in the system must not be higher than max. connection pressure, see data plate. Also check the tightness at the filter. If leaks are found during measurement, locate the source using soapy water or leak detection spray. After sealing: check the leakage of the gas fixture again.



Check for leaks in the gas line.

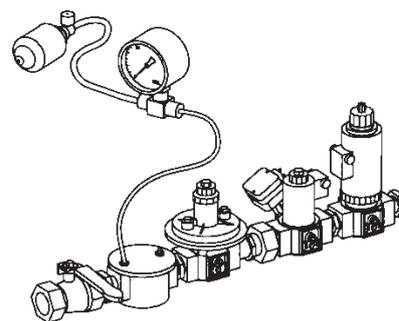
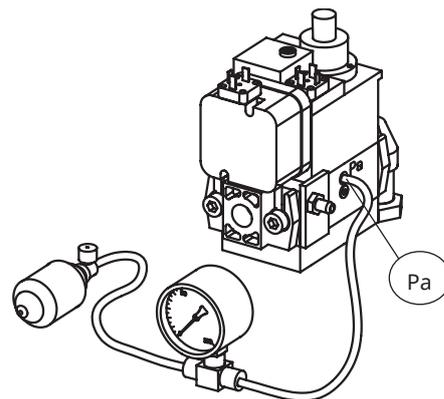

5.4 Calculation of gas flow

Formula symbol	Description	Example values
V_N	Standard gas volume [Nm ³ /h] Gas volume at normal condition 15 °C 1013 mbar	-
Q	Boiler output [kW]	770 kW
H_i	Lower calorific value of gas [kWh/m ³] Natural gas under normal conditions 15 °C 1013 mbar, EN 676	9.45 kWh/m ³
η	Boiler efficiency (e. g. 90%)	0.9
f	Conversion factor (pressure and temperature compensation)	-
t_{Gas}	Gas temperature at gas meter [°C]	15 °C
P_{Baro}	Barometric air pressure [mbar]	945 mbar
P_{Gas}	Pressure of gas at the gas meter [mbar]	20 mbar
V	Operating volume [m ³ /h]	-
VG	Gas flow measured at the gas meter [m ³]	2.59 m ³
T	Measuring time for consumed gas quantity [s]	93 s

Calculate standard volume using the following formula:

$$V_N = \frac{Q}{\eta \cdot H_i} \quad V_N = \frac{770 \text{ kW}}{0.9 \cdot 9.45 \text{ kWh/m}^3} = 90.5 \text{ m}^3/\text{h}$$

Calculate conversion factor using the following formula:

$$f = \frac{273}{273 + t_{Gas}} \times \frac{P_{Baro} + P_{Gas}}{1013} \quad f = \frac{273}{273 + 15} \cdot \frac{945 + 20}{1013} = 0.90$$

Calculate gas volume using the following formula:

$$V = \frac{V_N}{f} \quad V = \frac{90.5 \text{ m}^3/\text{h}}{0.90} = 100.3 \text{ m}^3/\text{h}$$

Determine operating volume with the following formula:

$$V = \frac{3600 \cdot V_G}{T} \quad V = \frac{3600 \cdot 2.59 \text{ m}^3}{93 \text{ sek}} = 100.3 \text{ m}^3/\text{h}$$

Height above sea level [m]	0	100	200	300	400	500	600	700	800	900	1000	1100	1200
P_{Baro} [mbar]	1013	1001	989	977	966	954	943	932	921	910	899	888	877

Calorific value of the gas

Gas quality		kWh/Nm ³	MJ/Nm ³
Natural gas	G20	9.5	34.02
Natural gas	G25	8.2	29.25

Gas quality		kWh/Nm ³	MJ/Nm ³
Butan	G30	32.25	116.09
Propan	G31	24.44	88.00
Biogas		6.0	21.60

Lower calorific value H_i at normal conditions 15 °C and 1013 mbar, EN 676.
For exact calorific value of the gas, contact the gas distributor.

6. Settings

6.1 Setting the combustion assembly

The burner is equipped with a lever that changes the position of the brake plate in the combustion head. This is used to set the correct pressure drop across the combustion assembly and thereby obtain good combustion without ripples.

Make the adjustment by turning screw X.

The best position is, among other things, dependent on the input power and overpressure in the boiler.

A general rule of thumb is that the smaller the capacity, the smaller the gap should be between the brake plate and the combustion assembly.

The position of the brake plate also has an impact on the quantity of air supplied for combustion. This means that once the brake plate has been adjusted, the combustion should be checked and, if necessary, the setting of the air damper adjusted to obtain good combustion.

A left turn opens the brake plate, providing a lower pressure drop and more air to the combustion process.

A right turn closes the brake plate, providing a higher pressure drop and less air to the combustion process.

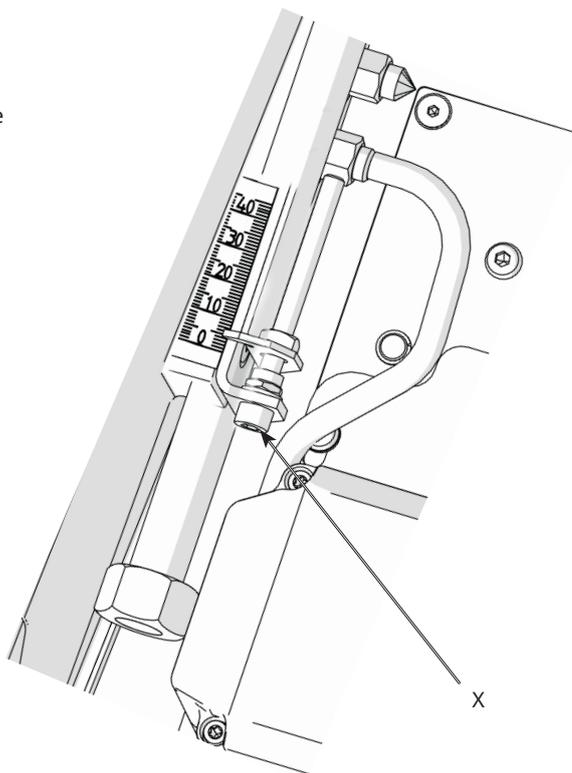

6.2 Startup

After the burner has been mounted on the boiler and the electrical connection, de-aeration and tightness control have been performed, the burner is ready to start-up.

Read the sections dealing with settings of gas valve, damper motor and combustion device before start-up.

Open the ball valve and turn on the main switch, start the burner and begin setting up the system.

6.3 Control of combustion

Check combustion using flue gas analysis instruments. Set the burner to about 20% excess air and check that good combustion is obtained. Check the actual gas flow on the gas meter to ensure that the correct input power is achieved.

6.4 Setting the air pressure switch

The air pressure switch must block the burner if the amount of air for combustion becomes too low. The air pressure switch must be set so that in the event of a lack of air supply at the burner's max. or min. capacity reacts before the monitored pressure drops so much that poor combustion occurs.

1. Remove protective cover.



Be careful when adjusting the air pressure switch; it contains a live component.

2. Start the burner.
3. Carefully turn the scale on the air pressure switch clockwise until the air pressure switch stops the burner.
4. Measure and note the lowest air pressure in the entire work area.
5. Set the air pressure switch to about 10-15% lower than the lowest noted pressure.
6. Test run the burner and check the function in the entire work area.
7. Refit protective cover.

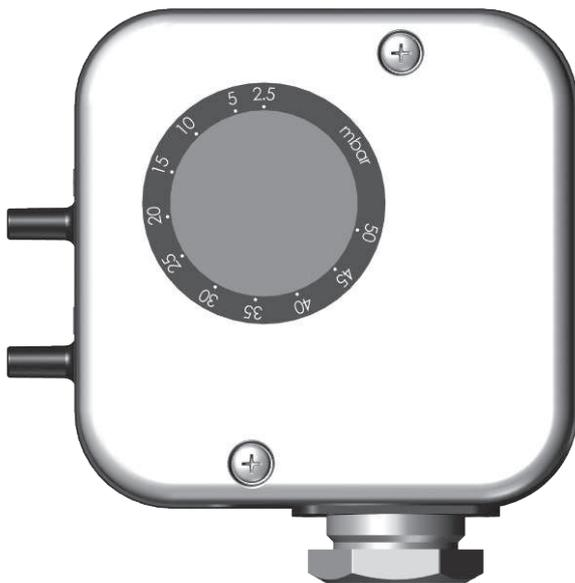

6.5 Setting the gas pressure switch, min.

The gas pressure switch must react to too low a connection pressure to the burner, prevent the burner from starting and stop the burner during operation. The burner may start again when the connection pressure has risen above the set pressure on the gas pressure switch.

1. Remove protective cover.
2. Open measuring socket and connect a manometer for measuring connection pressure.
3. Start the burner.
4. Measure and note the connection pressure to the burner at the highest input power.
5. Set the gas pressure switch to a value 10-15% lower than the noted pressure.
6. Check the setting by carefully closing the ball valve and at the same time measuring the connection pressure.
7. When the gas pressure switch stops the burner, the measured value must approximately correspond to the setting on the gas pressure switch.
8. Open ball valve.
9. Remove manometer and close measuring socket.
10. Refit protective cover.



Check gas tightness.

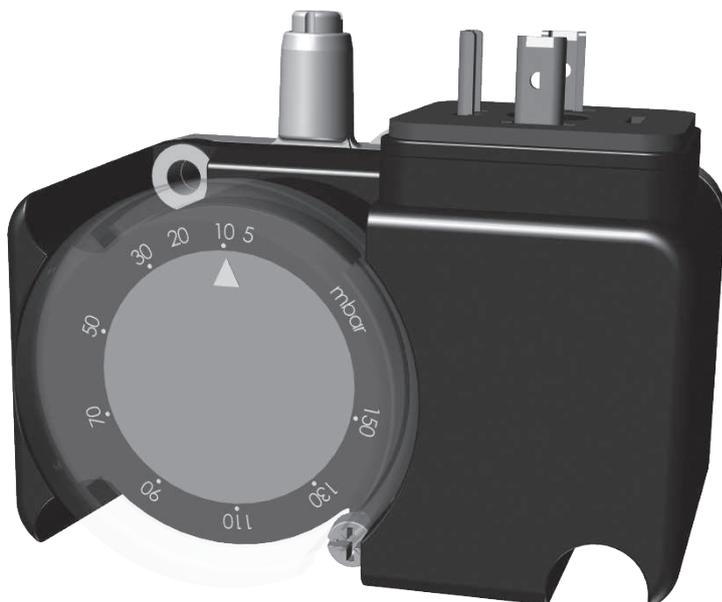

6.6 Setting Damper motor, Modulating operation

Air adjustment

The damper motor rotates the air damper between three preset positions: completely closed, low load and high load. These positions are controlled in the motor by colored cam discs:

- Orange cam disc is adjusted for low load (approx. 5-10°).
- Red cam disc is adjusted for high load (approx. 90°).
- Blue cam disc is factory set for closed air damper during standstill.
- Black cam disc has no function during sliding and modulating operation.

Setting amount of gas

- Before starting the burner, vent the line so that gas is safely available at the gas valve.
- Connect a manometer for measuring outlet pressure (PBr).
- Set the control switch to the MAN position.
- Set gas pressure switch min and air pressure switch in position MIN and (if mounted) gas pressure switch max in position MAX.
- Start burner. If no flame is formed and the manometer does not give a reading, adjust the amount of gas by increasing with screw N on the gas valve. Check combustion values.
- Set high load by pressing "+" control switch (increase). Adjust the amount of gas with screw V on the gas valve and check the combustion values.

- Return to low load "-", check combustion value and adjust if necessary.
- If necessary, repeat the setting on low (N) and high load (V).
- Adjust the orange and red cam discs to obtain the desired effect on low and high loads. Check the amount of gas on the system's gas meter.
- Adjust air and gas pressure switches after adjustment, see special instructions.
- Set the control switch to the AUTO position.

Release

By pressing the button, the motor is disengaged and the air damper can be turned. The function is used when servicing air dampers.

Recommended excess air

Gas quality	Excess air flue gases% O ₂
Natural gas	4 ±1
Propane	
Butane	
Liquefied petroleum gas	
Biogas	

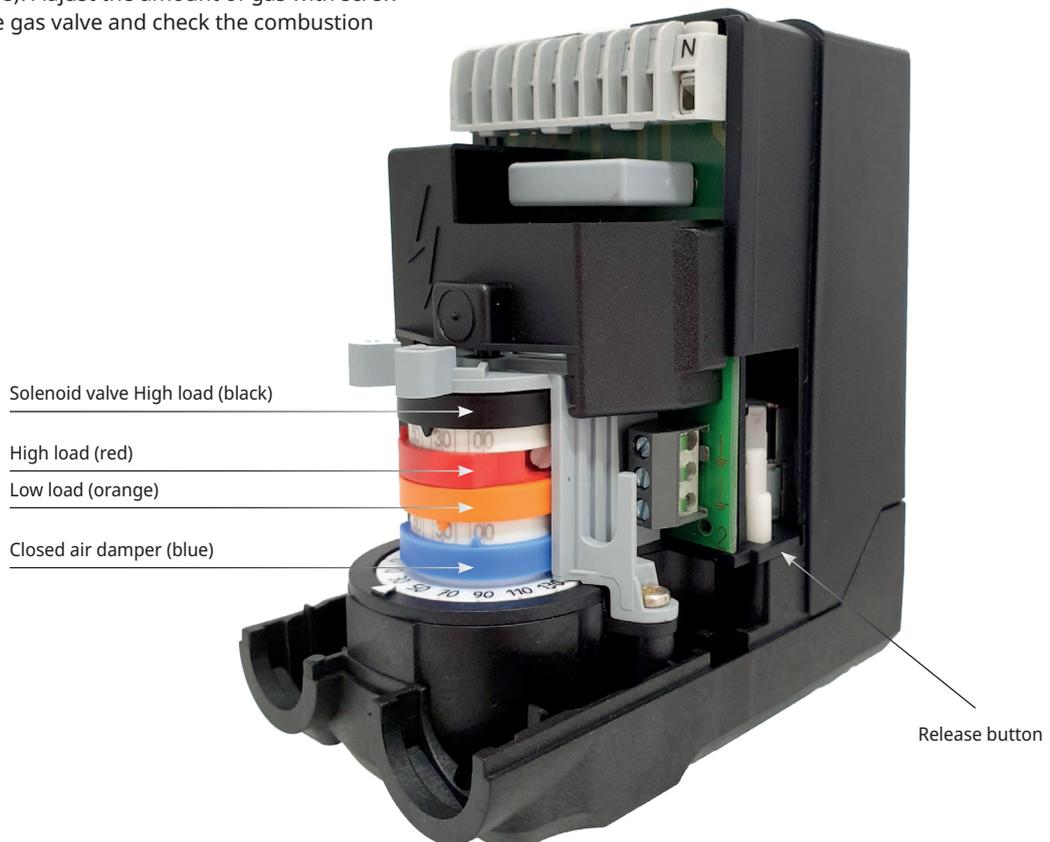

7. Gas valve, MultiBloc VEF 415-425 B01

! All components must be installed without being bent, twisted or subjected to mechanical or thermal forces which can affect the components.

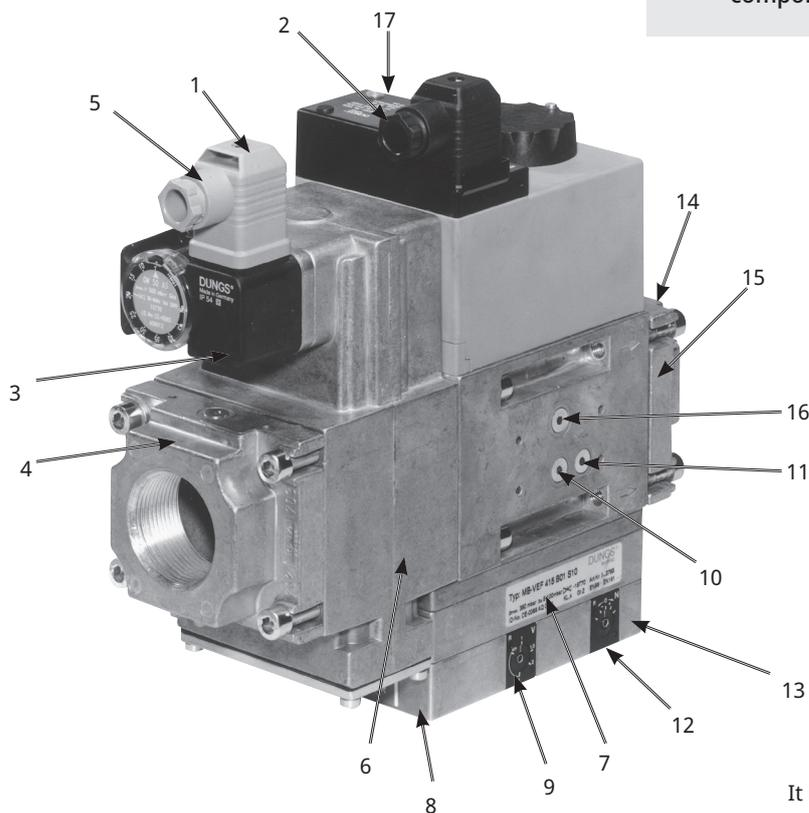

It is possible to connect a leakage control VPS 504 and a gas pressure switch max to the gas valve.

- | | |
|--|--|
| 1. Electrical connection gas pressure switch min | 11. Connection for measurement of burner pressure after V2 |
| 2. Electrical connection gas valve | 12. Adjustment screw for zero point adjustment N (min. load) |
| 3. Pressure switch min | 13. Test point connection 1/8" P _F |
| 4. Flange connection inlet | 14. Test point connection 1/8" P _{Br} (after V2 burner) |
| 5. Test point connection 1/8" before V1 | 15. Flange connection, outlet |
| 6. Filter (on MultiBloc 425 external filter) | 16. Test point connection 1/8" Pa before V2 (after governor) |
| 7. Data plate | 17. Indication of V1 and V2 in operation (not standard) |
| 8. Connection 1/8" P _L | |
| 9. Adjustment screw V for ratio P _{Br} : P _L (max. load) | |
| 10. Test point connection 1/8" before V1 (before governor) | |

7.1 Technical data

- Max inlet pressure 360 mbar (according to IEC 529, DIN 40050)
- Valves V1+V2 class A group 2 in accordance with EN 161
- Governor class A group 2 in accordance with EN88
- Ratio $V_{P_{Br}:P_L}$ 0,75:1-3:1
- Filter according to DIN 3386
- Ambient temperature -15°C- +70°C
- Protection standard type IP54
- Gas family 1 +2 +3
- Outlet pressure 0,5 - 100 mbar
- Zero point adjustment $N \pm 2$ mbar
- Pressure switch DIN3398 TI
- Fan pressure P_L 0,4 - 100 mbar
- Fire room pressure P_F -2 - +5mbar
- Burner pressure P_{Br} 0,5 - 100 mbar

7.2 Mounting instruction - impulse lines P_L , P_F and P_{Br}

- Impulse lines should preferably be made of steel. Inside diameter $>\phi 4$ mm (steel tube $\phi 6/4$).
- For P_L other material can be used.
- Impulse lines P_L and P_{Br} are ready from factory.
- Impulse lines shall be mounted in such a way that no condensate can flow back into the multibloc. This is especially important when P_F is concerned.
- Impulse lines shall be mounted in such a way that they are protected against rupture and damage.
- Impulse lines shall be as short as possible.

7.3 Adjustment possibilities

Adjustment range



Effective burner pressure

$$\Delta P_{Br} = P_{Br} - P_F$$



Effective fan pressure

$$\Delta P_L = P_L - P_F$$

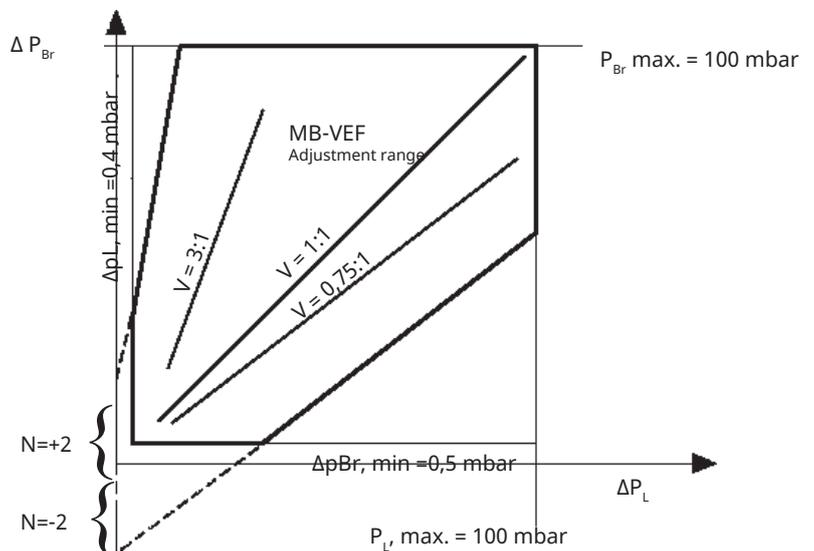
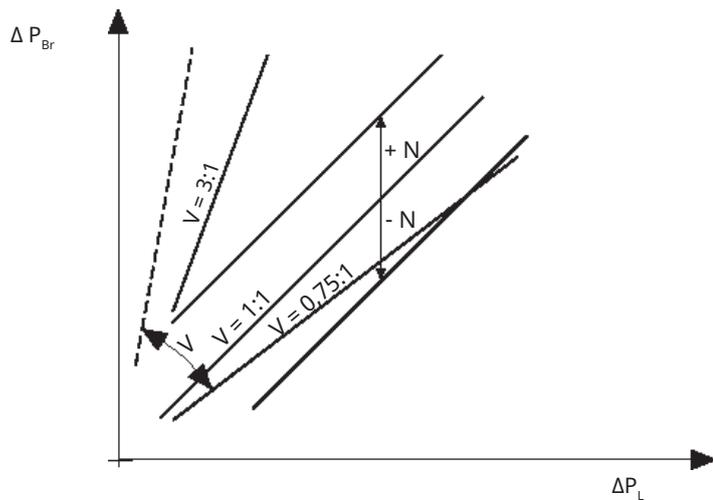

7.3.1 Pressure taps

MB-VEF 415
MB-VEF 420

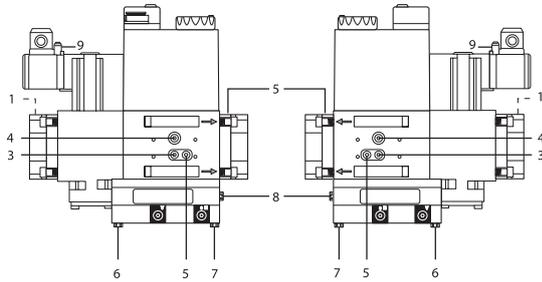

MB-VEF 425

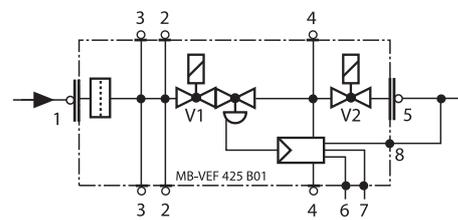
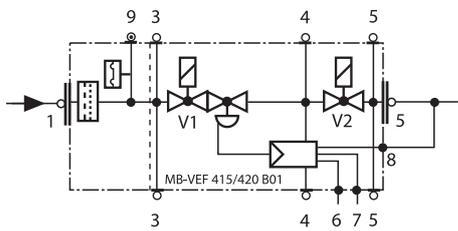
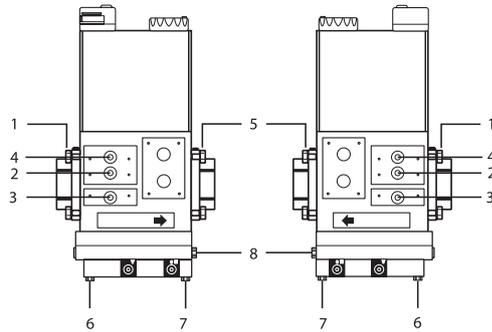

1, 2, 3, 4, 5 G1/8 screwed seal plug

9 Test nipple

6, 7, 8 Pulse lines P_L , P_F and P_{Br}

7.3.2 Electrical connection

S 10/S 30

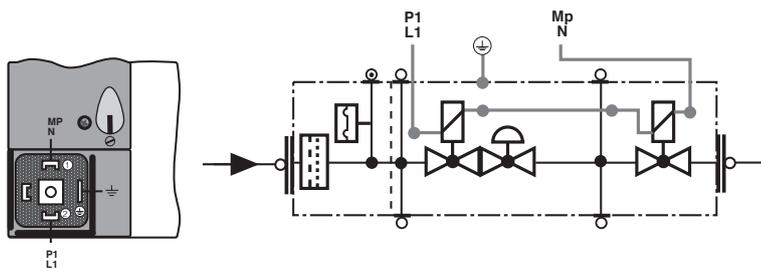

S 12/S 32

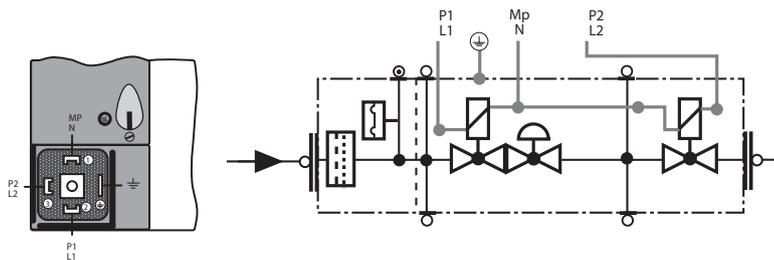

8. Service

Service and maintenance work may only be performed by qualified personnel. Perform operational check of all safety systems and components at each service. Only CTC original parts should be used when replacing components.



Use caution when operating the burner, surfaces may be hot.



8.1 Burner Service Schedule, Gas

Servicing must be carried out once a year or after 3,000 hours of operation.

Burner	1 year	3,000 h
Inspection of electrical installation	1 year	3,000 h
Leak check	1 year	3,000 h
Filter	1 year, replacement at $\Delta p > 10$ mbar	3,000 h, replacement at $\Delta p > 10$ mbar
Electrodes	Replacement/cleaning 1 year	Replacement/cleaning 3,000 h
Brake plate	Replacement/cleaning 1 year	Replacement/cleaning 3,000 h
Motor	1 year	3,000 h
Fan wheel	1 Year Replace if need for cleaning/imbalance	3,000 h Replace if need for cleaning/imbalance

8.2 Component replacement intervals

Components	Service life - Recommended replacement	Service life - Recommended replacement Operating cycles
Control system	10 years	250,000 starts
Valve control system	10 years	250,000 starts
Pressure switch	10 years	250,000 starts
Ignition system with flame guard	10 years	250,000 starts
UV flame sensor	10,000 h	N/A
Gas pressure controls	15 years	N/A
Gas valve without leak testing	10 years	250,000 starts
Gas valve with leak testing	Replacement upon fault detection	N/A
Gas pressure switch	10 years	250,000 starts
Safety blow-off system	10 years	N/A
Damper motor	N/A	500,000 starts
Contactors	10 years	500,000 starts



The burner and its components must be recycled according to applicable regulations.

8.3 Combustion device

1. Disconnect the main power and shut off the fuel supply.



Before obtaining access to electrical and fuel line components all supply circuits must be disconnected.

2. Remove cover (A), disconnect ignition and ionization cables and control arm (B) from nozzle assembly.
3. Loosen nut (C) and pull out the fan housing on the guides.
4. By loosening screw(s) (D), the combustion device is released and can be lifted out from the burner.
5. Check and clean the brake plate and gas inlet, replacing components as necessary.
6. Check that the ignition and ionisation electrodes are correctly set, (see Gas nozzle chapter) - replace if necessary.
7. Refit the combustion device in reverse order.
8. Press the burner together and lock with nut (C).
9. Switch on the main power and open the fuel supply.
10. Start burner and check/adjust combustion.



Check for leaks in the gas line.

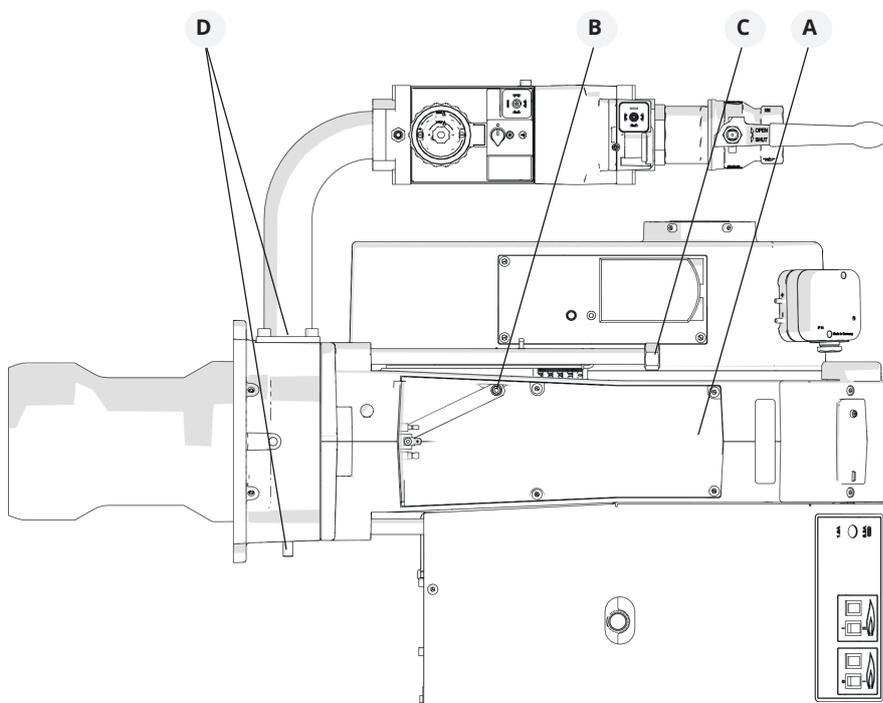

When servicing/replacing components that affect combustion, flue gas analysis and soot test must be carried out following installation.

8.4 Air damper

1. Disconnect the main power and shut off the fuel supply.



Before obtaining access to electrical and fuel line components all supply circuits must be disconnected.

2. Remove cover (A), disconnect ignition and ionization cables and control arm (B) from nozzle assembly.
3. Loosen nut (C) and pull out the fan housing on the guides.
4. Remove the intake grille (E) to the air intake.
5. Loosen screws (F) holding the damper motor fixing plate and lift the damper motor out.
6. Clean the air damper and air intake, lubricate the damper shaft if necessary.
7. Refit the damper motor and mounting plate, ensuring that the damper shaft and control arm are correctly connected.
8. Fit the intake grille.
9. Press the burner together and lock with nut (C).
10. Switch on the main power and open the fuel supply.
11. Start burner and check/adjust combustion.

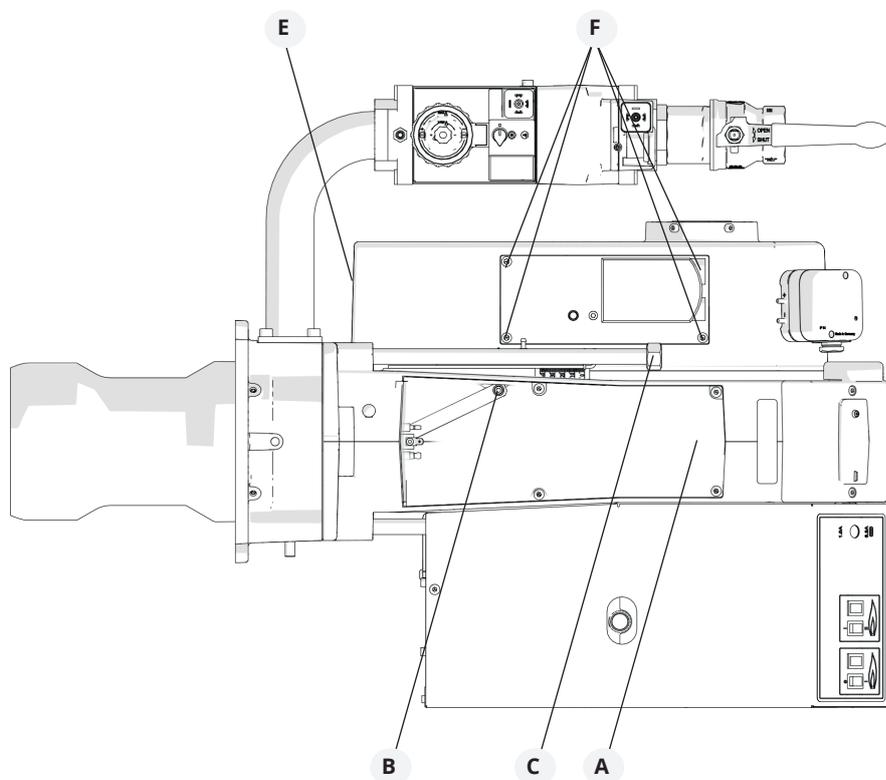

8.5 Replacement, Damper motor air

1. Disconnect the main power and shut off the fuel supply.



Before obtaining access to electrical and fuel line components all supply circuits must be disconnected.

2. Note the connection position of cables to the damper motor.
3. Disconnect cables from damper motor.
4. Loosen screws (G) to the damper motor fixing plate.
5. Disengage the damper motor and turn it to approx. 70°.
6. Lift up damper motor.
7. Remove the control arm (H) from the motor shaft.
8. Loosen screws (I) securing the damper motor to the fixing plate. Adjust the cams of the new damper motor according to the replaced motor, see chapter "Setting Damper motor" and fit the fixing plate.
9. Fit the control arm on the shaft of the damper motor. It is important that the screw is perpendicular to the flat surface of the shaft.
10. Refit the damper motor and mounting plate, ensuring that the damper shaft and control arm are correctly connected.
11. Connect the damper motor cable.
12. Switch on the main power and open the fuel supply.
13. Start burner and check/adjust combustion.



Releasing button

By pressing the button and snapping it down, the motor will be released and the damper can easily be turned. This function facilitates an exchange of damper motor.

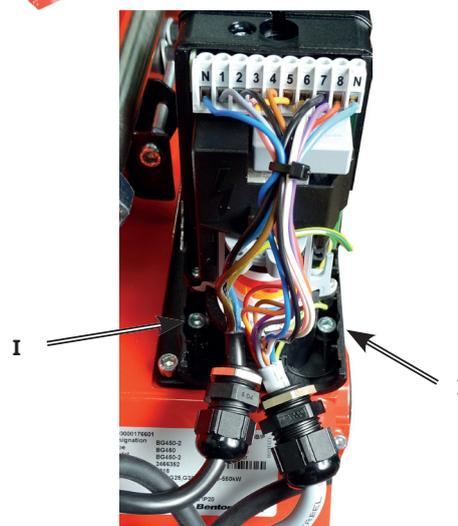
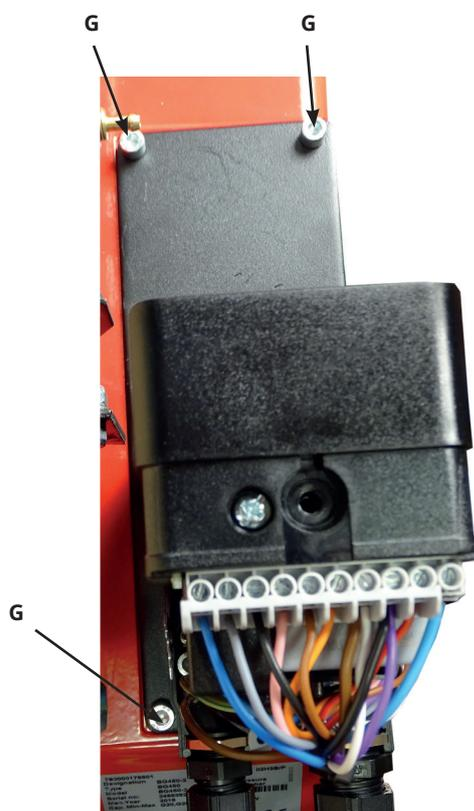
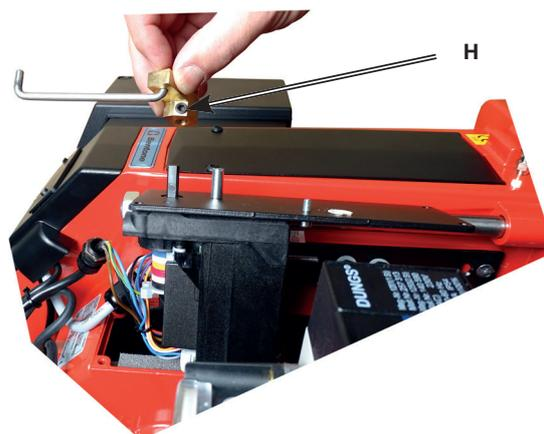

8.6 Fan

1. Disconnect the main power and shut off the fuel supply.



Before obtaining access to electrical and fuel line components all supply circuits must be disconnected.

2. Detach the electrical panel (Y).
3. Loosen the motor electrical connection and screws (X) enough to turn and lift out the motor.
4. Check the fan wheel attachment and any skew, replace if damaged.
5. Clean or replace the fan wheel.
6. Refit the parts.
7. Switch on the main power and open the fuel supply.
8. Start burner and check/adjust combustion.

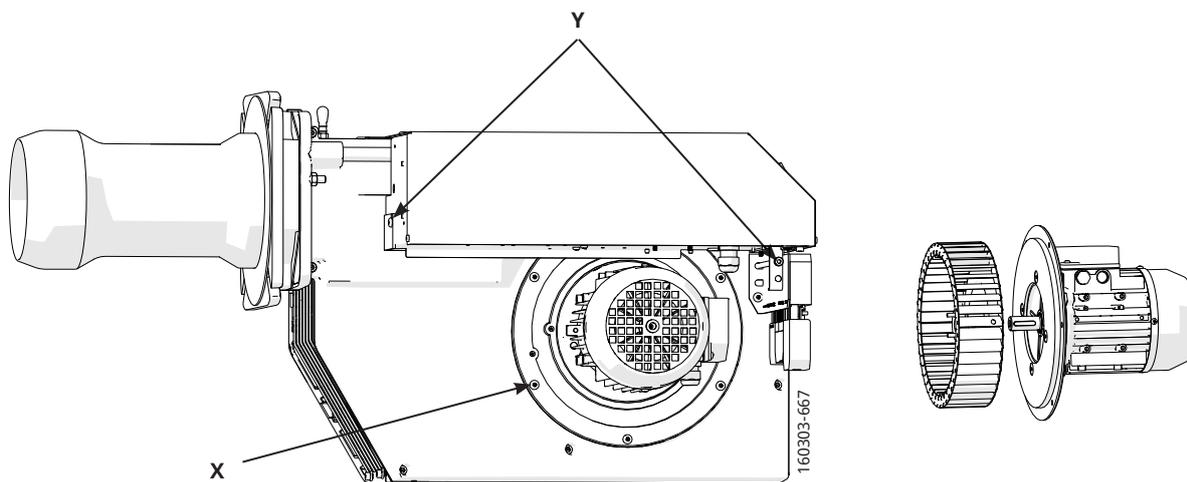

When servicing/replacing components that affect combustion, flue gas analysis and soot test must be carried out following installation.

8.7 Vibrations

Maximum permitted vibration level is 5.0 mm/s.

- Check tightness of fasteners.
- Check fan wheel for damage and contamination (replace if necessary).
- Check motor shaft and bearings. If they are worn, replace the motor.

Use screw to attach the vibration sensor.



8.8 Control of flame monitoring and ionization current

The burner is monitored in the standard version according to the ionization principle. The ionization current must be checked at each service occasion.

The ionization current is measured with a microammeter (μA) which is connected in series with the flame electrode and the gas burner control. Connect the μA meter as shown below. The minimum required ionization current is shown in the table. During normal operation, this current must be significantly higher, preferably more than $10 \mu\text{A}$.

The reason for too low ionization current can be creep current, poor connection to earth, dirt or that the flame electrode may need to be adjusted. The wrong gas/air mix can also cause too low ionization current.

Technical data	
Idle voltage at ION-terminals	AC 115-230V
Short-circuit current	Max. AC 100-300 mA
Min. current for flame detection	Min. DC $1.5 \mu\text{A}$
Required current to ensure detection	Min. DC $3 \mu\text{A}$
Possible detection current	Max. DC $20 \mu\text{A}$
Operational indicator lamp flashes green	$<5 \mu\text{A DC}$
Operational indicator lamp shines green	$>5 \mu\text{A DC}$

8.8.1 Flame monitoring ionisation

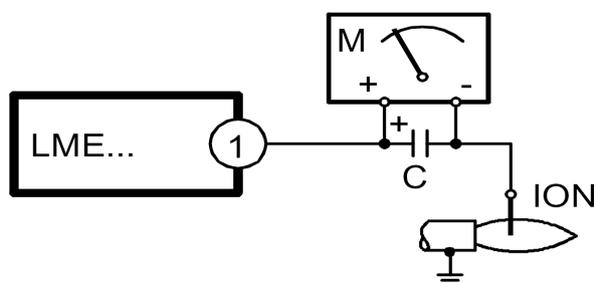

8.8.2 UV -detector (QRC)

The UV sensor should not be exposed to temperatures higher than 60 °C. The current passing through the UV sensor when it is lighted must be at least 70 μA . The current can be measured using a rotary coil instrument. A check is necessary only if a malfunction is suspected.

8.8.3 Flame monitoring UV-detector (QRC)

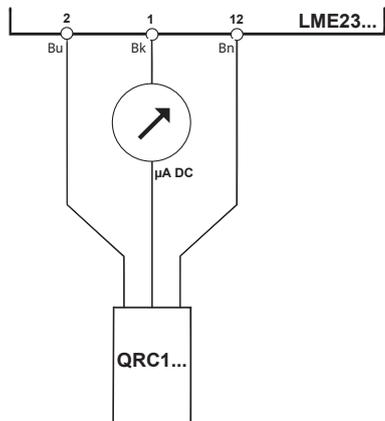

Technical data	
Idle voltage at ION-terminals	AC 115-230V
Short-circuit current	Max. AC 100-300 mA
Max. current for flame detection	Max. DC 5.5 μA
Required current to ensure detection	Min. DC 40 μA
Possible detection current	Max. DC 60 μA
Operational indicator lamp flashes green	<45 μA DC
Operational indicator lamp shines green	>45 μA DC

8.9 Replacement of electrical components

1. Disconnect the main power and switch off the fuel supply.



Before obtaining access to terminals, all supply circuits must be disconnected.

2. Note the connection of the existing component and disassemble.
3. Fit new component with same connection or with specified alternative connection.
4. Switch on the main power and check the operation of the new component.
5. Start burner and check/adjust combustion.



When servicing/replacing components that affect combustion, flue gas analysis and soot test must be carried out following installation.

9. Handing over of the installation

- Make repeated start attempts to ensure that the adjustments function.
- Close the ball valve during operation to check that the gas switch switches off at the set value.
- Remove the hose for the air pressure switch to check that the burner locks out.
- Check that all protective covers and measurement nipples are mounted and fastened.
- Fill out necessary test reports.
- Instruct the persons in charge of the operation on the service and maintenance of the installation and what to do should any troubles occur.
- Inspection and service must be carried out by authorized personnel.



Review and service should be performed by authorised personnel only.

10. Troubleshooting

Conditions favourable to trouble-free operation of the system can only be guaranteed through the interaction between three factors: electricity, gas flow and combustion air. If any of these factors change, it may cause a malfunction.

Before requesting servicing, check the following points:

1. Are the system's gas taps open?
2. Are the fuses intact and is the power on?
3. Are control devices (room thermostat, boiler thermostat, etc.) correctly set?
4. Is there sufficient gas pressure to the burner?
5. Are the burner controls on standby and not locked?
6. Is there sufficient air supply to the burner?

Cause of fault	Action
Burner does not start:	
No gas.	Make sure all gas taps are open.
No power.	Check the fuse, thermostat and electrical connections.
Burner motor does not start.	Motor protection has tripped. Motor faulty.
Burner control faulty.	Replace.

Burner motor running, no ignition spark at the end of pre-aeration:	
No power in the terminals.	Check the connector. Replace faulty burner controls.
Ignition electrodes in contact with each other or earth.	Adjust.
Ignition electrode porcelain damaged.	Replace the electrodes.
Poor connection to cable connectors.	Adjust connection.
Ignition cables damaged.	Replace.
Transformer damaged, no power to secondary winding.	Replace the transformer.
Ignition cable and ionisation cable swapped around.	Reconnect.

No flame propagation:	
Gas solenoid valve faulty.	Replace.
Gas solenoid valve does not open despite having power.	Replace solenoid valve terminals, or entire valve.
No power to solenoid valve.	Check the connection.
No electrical connection through air pressure gauge.	Check the air pressure gauge's settings and functions.
Ignition load incorrectly set.	Increase/decrease gas supply Reduce airflow.
Burner control faulty	Replace
Air pressure gauge incorrectly set or faulty	Check the settings and reset, or replace
No acknowledgement signal due to incorrect adjustment or misalignment of the control motor cams.	Check the settings and realign.

Burner trips after safety time limit despite flame propagation:	
No ionisation current or UV cell incorrectly positioned.	Adjust ionisation electrode and UV cell Check cables and connectors.
Burner control monitor faulty.	Replace burner control.
Voltage lower than 185V.	Contact an electrician.
Ignition electrodes disrupting ionisation current.	Adjust ignition electrodes. Re-polarise the transformer.
Poor earth connection.	Ensure adequate earth connection.
Phase and neutral swapped around.	Check wiring diagram and change accordingly.

Cause of fault	Action
Burner trips during pre-aeration:	
Air sensor faulty or incorrectly set.	Increase/decrease air setting. Reduce air volume.
Ignition load incorrectly set.	Increase/decrease gas supply Reduce airflow.
Gas pressure too low.	Increase pressure. If necessary, contact gas supplier.

Pulsations at start-up:	
Ignition electrodes incorrectly set.	Adjust .
Gas pressure too high.	Check and adjust using pressure gauge and pressure control valve.
Flue gas side blocked.	Check the chimney flue.

Burner pulsates during operation:	
Burner incorrectly set.	Adjust.
Burner dirty.	Clean the burner.
Incorrect chimney.	Check and modify dimensions if necessary.

Burner functioning properly but with occasional blockage:	
Ionisation current too low.	Check. Must be at least 6 μ A, but should ideally lie between 8-20 μ A.
UV cell incorrectly positioned.	Adjust.
Voltage drop at certain times.	Must not drop below 15% of rated voltage. Contact an electrician if necessary.
Incorrectly set or faulty air sensor.	Check the settings and reset, or replace.
Ignition electrode overload.	Replace.
Burner control ambient temperature too high.	Insulate for heat, Max. 60 °C.
Ignition spark too weak.	Check the transformer.

Poor combustion:	
Poor draught conditions.	Check the chimney.
Flue gas temperature too high.	Boiler overloaded Decrease the gas volume, sweep the chimney if necessary.
CO2 content too low.	Choke the air supply. Check the boiler for any leakages. Choke the draught if too high.

CO content too high:	
Surplus air when using natural gas and liquefied petroleum (propane, butane).	Choke the air supply.
Poor air supply.	Open the air supply. Check flue gas damper.
Holes in gas nozzle clogged.	Clean.
Poor fresh air intake.	Check and increase.
Flame at incorrect angle due to combustion head out of position.	Check the combustion head and readjust.

Condensation build up in boiler and chimney:	
Flue gas temperature too low or gas volume too low.	Raise the flue gas temperature by increasing gas volume Insulate the chimney.

11. Service- and inspection protocol

Installation:	Boiler:	
Name:	Type:	Efficiency kW:
Address:	Burner	
	Type:	Efficiency kW:
Installed by:	Date:	

Date	Nm ³ gas/h	Governor		CO ₂ %	CO %	Fluegas temp °C	Ionisation current µ A	Pressure		Efficiency %
		Before	After					Fire room mbar	Chimney mbar	
		Measurement	Small Flame							
	Large Flame									
	Measures									

Date	Nm ³ gas/h	Governor		CO ₂ %	CO %	Fluegas temp °C	Ionisation current µ A	Pressure		Efficiency %
		Before	After					Fire room mbar	Chimney mbar	
		Measurement	Small Flame							
	Large Flame									
	Measures									

Date	Nm ³ gas/h	Governor		CO ₂ %	CO %	Fluegas temp °C	Ionisation current µ A	Pressure		Efficiency %
		Before	After					Fire room mbar	Chimney mbar	
		Measurement	Small Flame							
	Large Flame									
	Measures									



EU Declaration of conformity

Bentone Gas Burners

Type:	Certificate No.	Type:	Certificate No.
BFG 1	CE-0123CT1269	BG 550	CE-0123CT1326
STG 120	CE-0123CT1270	BG 650	CE-0123CT1348
STG 146	CE-0123CT1281	BG 700	CE-0123CT1359
BG 300	CE-0123CT1292	BG 800	CE-0123CT1360
BG 400	CE-0123CT1304	BG 950	CE-0123CT1371
BG 450	CE-0123CT1315		

This declaration of conformity is issued under the sole responsibility of the manufacturer.
The object of the declaration described above is in conformity with:

- **Gas Appliance Regulation 2016/426/EU**
- **Machinery Directive 2006/42/EC**
- **LVD 2014/35/EU**
- **EMC 2014/30/EU**
- **The Restriction of the Use of Certain Hazardous Substances (RoHS) Directive 2011/65/EU**

References to the relevant harmonised standards used or references to the other technical specifications in relation to which conformity is declared:

EN 676:2020 Excluding the requirements of Annex K.
Automatic forced draught burners for gaseous fuels.

Additional information can be downloaded at: www.bentone.com

Manufacturer: CTC AB
Näsvägen 8
SE-341 34 LJUNGBY
Sweden

Notified Body: TUV SÜD Product Service GmbH
Ridlerstraße 65
D-80339 München, Germany
Notified Body Number: 0123

Ljungby, 2024-01-01

Joachim Hultqvist
Technical Manager
CTC AB

Ola Karlsson
Quality Manager
CTC AB

UK Declaration of conformity

Bentone Gas Burners

Type:

BFG 1	BG 300	BG 550	BG 800
STG 120	BG 400	BG 650	BG 950
STG 146	BG 450	BG 700	

This declaration of conformity is issued under the sole responsibility of the manufacturer.
The object of the declaration described above is in conformity with:

- **Gas Appliances (Enforcement) and Miscellaneous Amendment Regulations 2018**
- **Supply of Machinery (Safety) Regulations 2008**
- **Electrical Equipment (Safety) Regulations 2016**
- **Electromagnetic Compatibility Regulations 2016**
- **The Restriction of the Use of Certain Hazardous Substances in Electrical and Electronic Equipment Regulations 2012**

References to the relevant harmonised standards used or references to the other technical specifications in relation to which conformity is declared:

BS EN 676:2020 Excluding the requirements of Annex K.
Automatic forced draught burners for gaseous fuels.

Additional information can be downloaded at: www.bentone.com

Manufacturer: CTC AB
Näsvägen 8
SE-341 34 LJUNGBY
Sweden

Approved Body: TUV SÜD BABT Unlimited
Octagon House,
Concorde Way, Segensworth North,
Fareham, Hampshire,
PO 15 5RL, United Kingdom
Approved Body Number: 0168

Ljungby, 2024-01-01

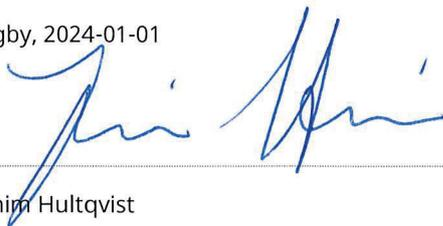

Joachim Hultqvist

Technical Manager
CTC AB



Ola Karlsson

Quality Manager
CTC AB



CTC AB Box 309 SE-341 26 Ljungby
info@bentone.se +46 372 88 000
www.bentone.se