



Providing sustainable energy solutions worldwide

Installation- and maintenance instruction
B40 CN

DESCRIPTION

Components

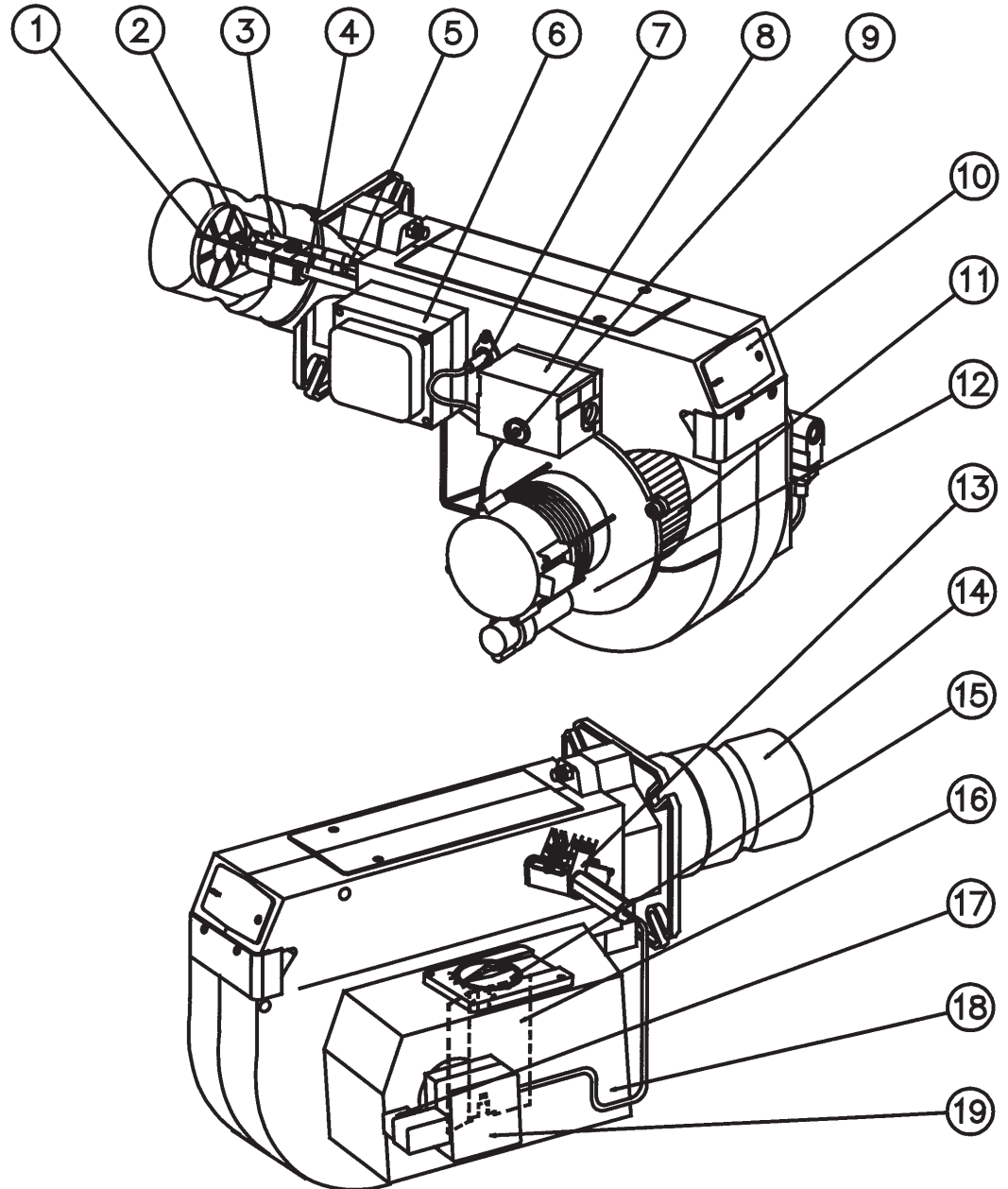

1. Shrouded disc
2. Nozzle
3. Ignition electrodes
4. Nozzle assembly
5. Ignition cable
6. Ignition transformer
7. Photo cell

8. Control box
9. Reset button
10. Cover, inspection glass
11. Fan wheel
12. Motor
13. Nozzle assembly adjustment
14. Blast tube

15. Air adjustment
16. Air damper
17. Solenoid valve
18. Air intake
19. Pump

TECHNICAL DATA

Type designation B 40

Dimensions

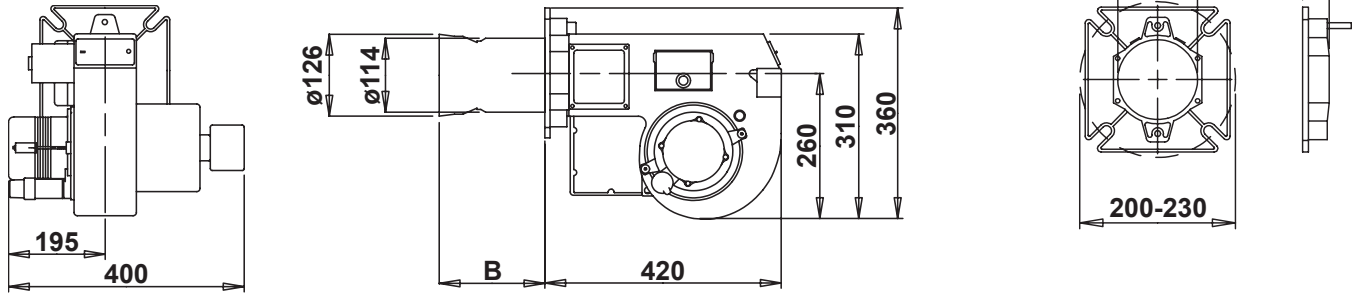

Burner tube	Length of burner tube	Measure B
N	202	172
N	302	272

Output range and nozzles recommended

Burner tube	Oil capacity		Output		Recommended Nozzle		Recommended Pump pressure
	kg/h	kW	Mcal/h	Angle	Type	Bar	
N	9,0-29,5	107-350	92-301	45°, 60°	S, B, R, PLP	10-15 bar	

The net calorific value of 11,86 kWh/kg for light oil has been used.

Recommended nozzle

Because of different boiler types existing on the market, with varying combustion chamber designs, it is

not possible to state a definite spray angle or spray pattern.

Note that the spray angle and the spray pattern change with the pump pressure.

Electrode adjustment

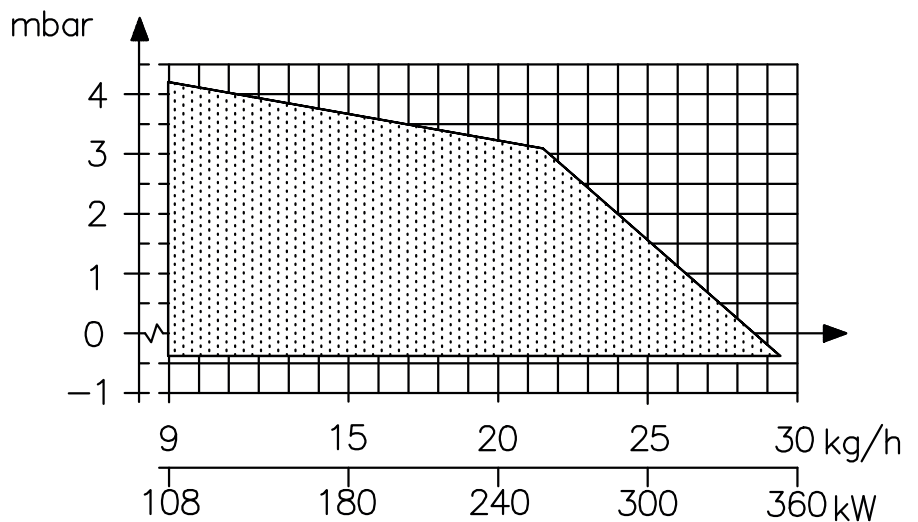
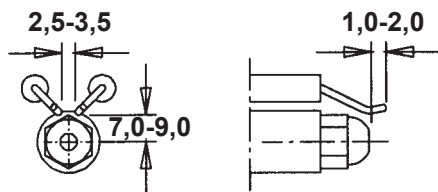

GENERAL INSTRUCTIONS

General rules

The installation of an oil burner should be carried out in accordance with local regulations. The installer of the burner must therefore be aware of all regulations relating to oil and combustion. Only oil suitable for the burner should be used and then in combination with a suitable oil filter before the oil pump of the burner.

If the burner is replacing an existing burner make sure that the oil filter is replaced or cleaned. The installation must only be undertaken by experienced personnel. Care should be taken by the installer to ensure that no electrical cables or fuel/gas pipes are trapped or damaged during installation or service/maintenance.

Installation instructions

General installation instructions accompany the burner and should be left in a prominent place adjacent to the burner.

Adjustment of burner

The burner is from the factory pre-set to an average value that must then be adjusted to the boiler in question. All burner adjustments must be made in accordance with boiler manufacturers instructions. These must include the checking of flue gas temperatures, average water temperature and CO₂ or O₂ concentration.

To adjust the combustion device, start by increasing the air volume and the nozzle assembly somewhat. When the burner starts it is burning with excess air and smoke number 0. Reduce the nozzle assembly adjustment until soot occurs, and then increase the adjustment to make the soot disappear again. Then the volume of air is reduced until soot occurs and increased again to reach a combustion free of soot.

By this procedure an optimum adjustment is obtained. If larger nozzles are used the preadjustment of both the air volume and the nozzle assembly must be increased.

A whistling sound may be heard which can be eliminated or reduced as follows: Increase the nozzle assembly adjustment somewhat. The CO₂-content and consequently the air volume will then be reduced.

Condensation in chimney

A modern burner works with less excess air and often also with smaller nozzles than older models.

This increases the efficiency but also the risk of condensation in the chimney.

The risk increases if the area of the chimney flue is too large. The temperature of the flue gases should exceed 60°C measured 0,5 metres from the chimney top.

Measures to raise the temperature:

Insulate the chimney in cold attics

Install a tube in the chimney

Install a draught regulator (dilutes the flue gases during operation and dries them up during standstill)

Increase the oil quantity

Raise the flue gas temperature by removing turbulators, if any, in the boiler.

Pump adjustment

See separate description.

Maintenance

The boiler/burner should be examined regularly for any signs of malfunction or oil leakage.

Oil supply

The oil line should be dimensioned in accordance with the pump manufacturer's instruction. In the suction line to the burner a filter should be mounted to prevent any particles in the oil from reaching the burner. If the installation consists of several burners each one should have its own suction line from the tank or a circulation system should be used.

The temperature in the oil line should be kept as constant as possible. Avoid exposing the line to excessive cold which may cause blockages of paraffin deposits.

The oil pipe and electric cable should be fitted so that the burner can be placed on the floor for inspection of the combustion device

Adjustment of nozzle assembly

Loosen the locking screw B and adjust the nozzle assembly to the desired position. Lock the screw B again.

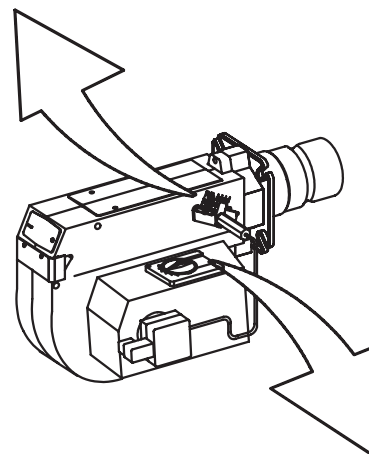
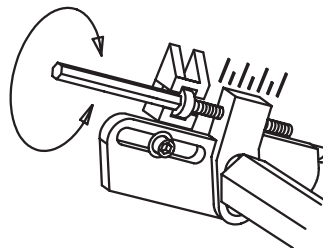

Air adjustment 0-10

Loosen the stop screw B and turn the knob along the scale to the desired position and tighten the screw. Check the air adjustment by making a flue gas analysis.

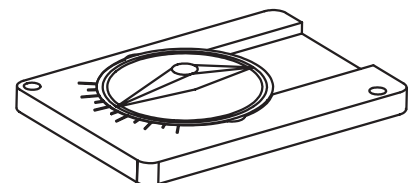

MAINTENANCE OF OIL BURNER

Warning: Before doing any service switch off power at the main switch and cut off the oil supply.

Service of burner head

Open the cover and disconnect the connecting pipes by loosening screw A.

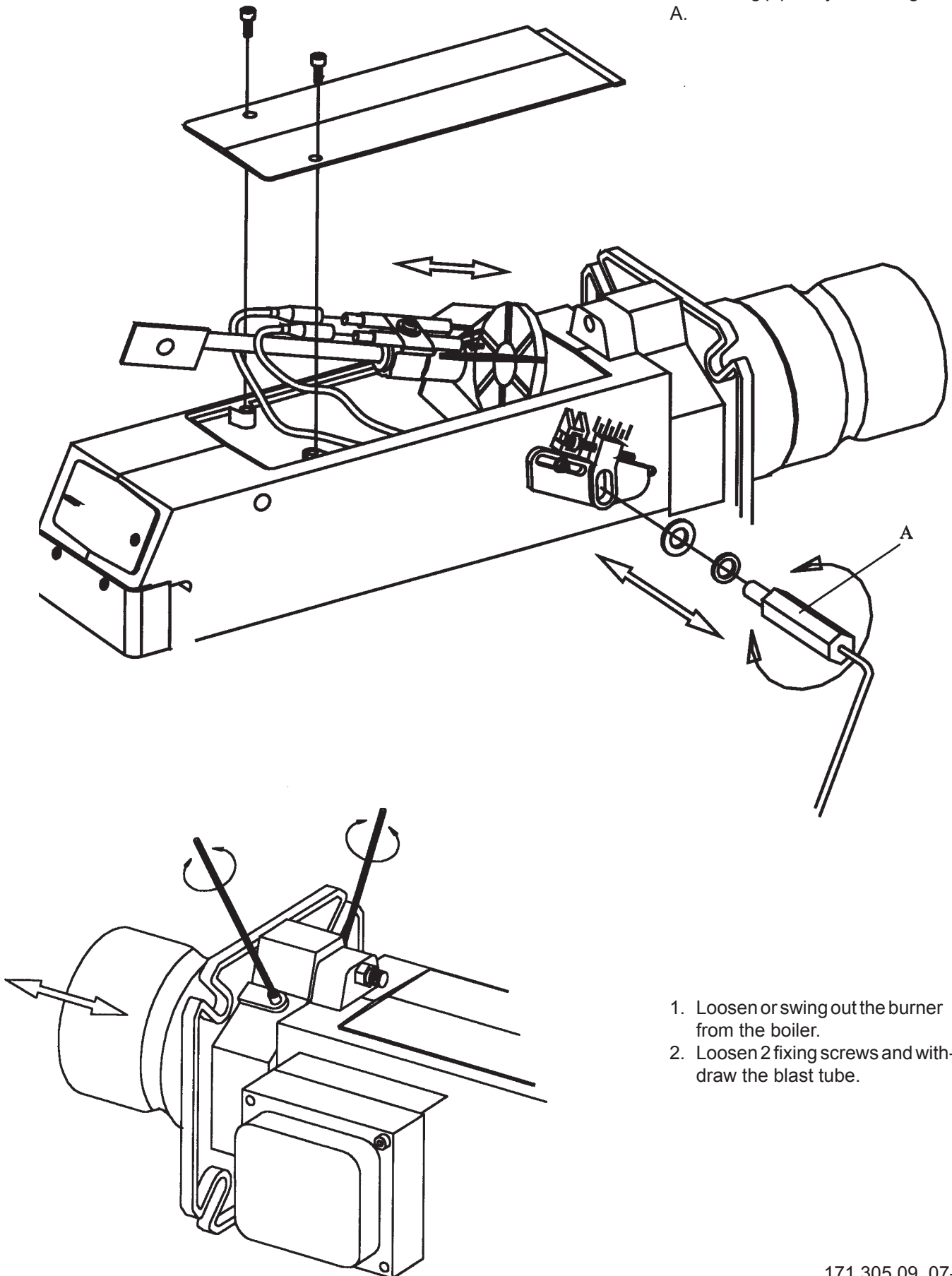

1. Loosen or swing out the burner from the boiler.
2. Loosen 2 fixing screws and withdraw the blast tube.

ELECTRIC EQUIPMENT

Oil burner control: LOA24..

List of components

- A1 Oil burner control
- A2 Twin thermostat
- F1 Fuse, max. 10A
- H1 Alarm lamp
- H2 Signal lamp (optional)
- M1 Burner motor
- P1 Time meter (optional)
- R1 Photoresistor
- S3 Main switch
- T1 Ignition transformer
- Y1 Solenoid valve

Mains connection and fuses in accordance with local regulations.

Wiring diagram

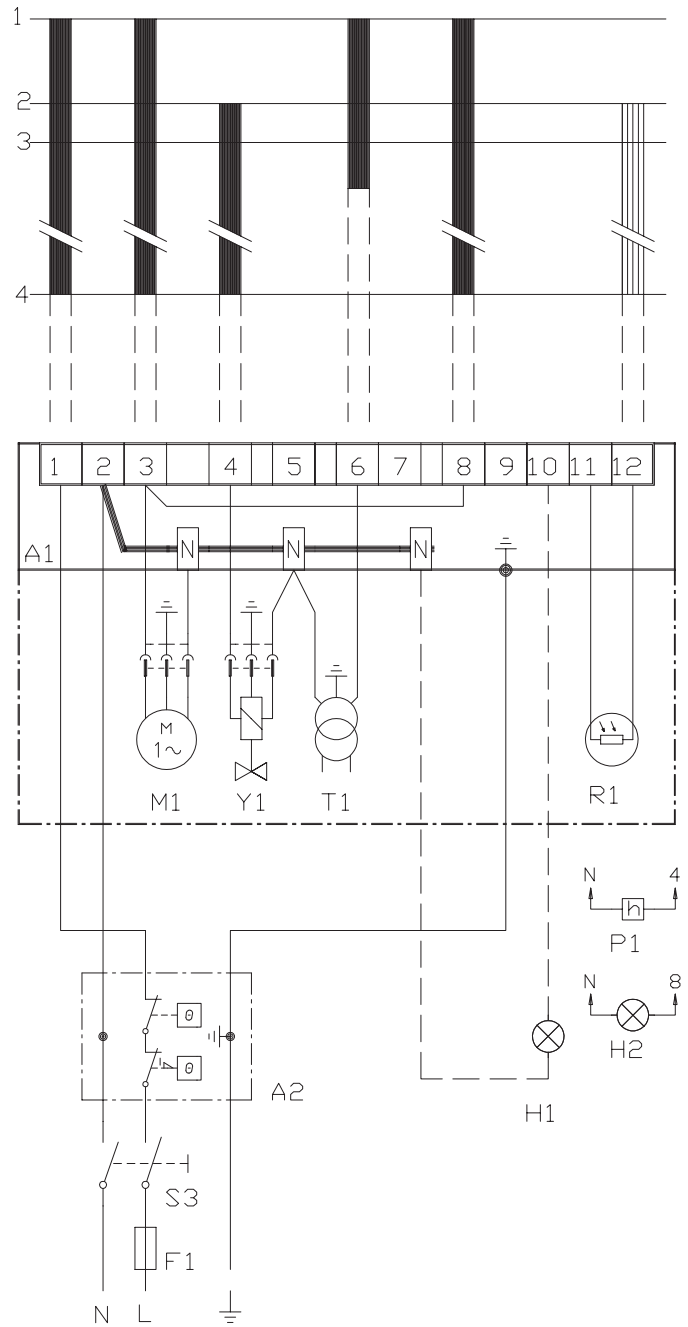

ELECTRIC EQUIPMENT

Oil burner control: LOA2..

Function

1. Switch on operating switch and twin thermostat

The burner motor starts, an ignition spark is formed, the prepurge goes on till the prepurge period expires and the solenoid valve opens (2).

2. Solenoid valve opens

Oil mist is formed and ignited. The photocell indicates a flame. The ignition spark goes out after flame indication (See Technical data oil burner control).

3. The safety time expires

- a. If no flame is established before this time limit the control cuts out.
- b. If for some reasons the flame disappears after this time limit, the burner will make an attempt to re-start.

3-4. Operating position

If the burner operation is interrupted by means of the main switch or the thermostat, a new start takes place when the conditions in accordance with point 1 are fulfilled.

The oil burner control cuts out

A red lamp in the control is lit. Press the reset button and the burner re-starts.

Technical data oil burner control

	LOA2...
Pre-ignition time:	13 s
Pre-purge time:	13 s
Post-ignition time:	15 s
Safety lock-out time:	< 10 s
Reset time after lockout:	< 50 s
Reaction time on flame failure:	< 1 s
Ambient temperature:	-20 - +60°C
Min. current with flame established:	65 µA
Max. photo current at start:	5 µA

Control of photo current

Current through photo unit is measured with a d.c. ammeter (a moving coil instrument connected in series with the photo unit).

INSTRUCTIONS PUMP TYPE DANFOSS BFP 21 L5

Technical data

Viscosity range: 1,8-12,0 mm²/s
 Pressure range: 7-15 bar
 Rated voltage of coil: 220/240V
 50/60 Hz
 Oil temperature: -10 to +70°C

Components

1. Nozzle port G1/8"
2. Pressure gauge port G1/8"
3. Pressure adjustment, 4 mm allen key
4. Cartridge filter
5. Vacuum gauge port G1/8"
6. Return line G1/4"
7. Suction line G1/4"
8. Return plug
9. Pressure gauge port G 1/8"

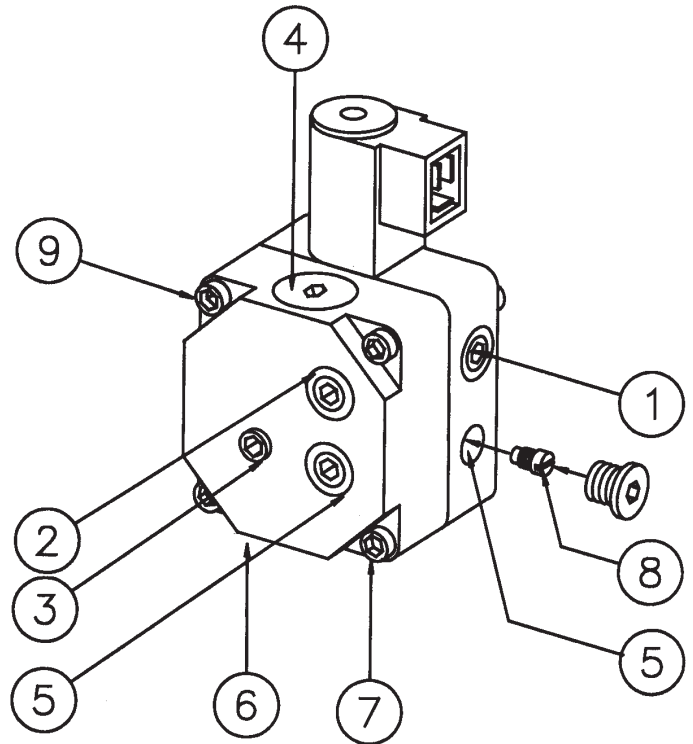

Suction line tables

The suction line tables consist of theoretically calculated values where the pipe dimensions and oil velocity have been matched so that turbulences will not occur. Such turbulences will result in increased pressure losses and in acoustic noise in the pipe system. In addition to drawn copper piping a pipe system usually comprises 4 elbows, a non-return valve, a cut-off valve and an external oil filter.

The sum of these individual resistances is so insignificant that they can be disregarded. The tables do not include any lengths exceeding 100 m as experience shows that longer lengths are not needed.

The tables apply to a standard fuel oil of normal commercial quality according to current standards. On commissioning with an empty tube system the oil pump should not be run without oil for more than 5 min. (a condition is that the pump is being lubricated during operation).

The tables state the total suction line length in metres at a nozzle capacity of 10,0 kg/h. Max. permissible pressure at the suction and pressure side is 2,0 bar.

Purging

On 1-pipe systems it is necessary to purge the pump. On 2-pipe systems purging is automatic through the return line.

1-pipe system Height Pipe diameter H ø5 mm ø6 mm ø8 mm m m m m 4,0 31 65 100 3,5 27 57 100 3,0 23 49 100 2,5 20 40 100 2,0 16 32 100 1,5 12 24 77 1,0 8 16 51 0,5 4 8 26		1-pipe system Height Pipe diameter H ø4 mm ø5 mm ø6 mm m m m m With an underlying tank a 1-pipe-system is not recommended	
Two-pipe system Height Pipe diameter H ø6 mm ø8 mm ø10 mm m m m m 4,0 21 67 100 3,5 20 63 100 3,0 19 59 100 2,5 17 55 100 2,0 16 51 100 1,5 15 46 100 1,0 13 42 100 0,5 12 38 94		Two-pipe system Height Pipe diameter H ø6 mm ø8 mm ø10 mm m m m m 0 11 34 84 -0,5 10 30 74 -1,0 8 26 64 -1,5 7 22 54 -2,0 6 18 44 -2,5 4 14 34 -3,0 3 10 24 -3,5 2 6 14 4,0 1 2 4	

INSTRUCTIONS PUMP TYPE DANFOSS BFP21L5

Function Danfoss BFP21L5

When the oil pump is started, oil is drawn from the suction connection (S) through the filter (H) to the suction side of the gear wheel (C).

The gear wheel then pumps oil to the pressure side and the oil is put under pressure.

The pressure is controlled and kept constant at the set value by the regulating valve (P_1) with the diaphragm (D). The regulating valve (P_1) distributes the oil quantity supplied by the gear set (C) between the nozzle port (E) and the return side of the pump (R). The oil quantity utilized is determined by the set pressure on the regulating valve (P_1) and the size of the oil nozzle in the nozzle line.

The valve (P_1) functions in the following way:

- When the opening pressure has been reached, the passage to the return side opens.

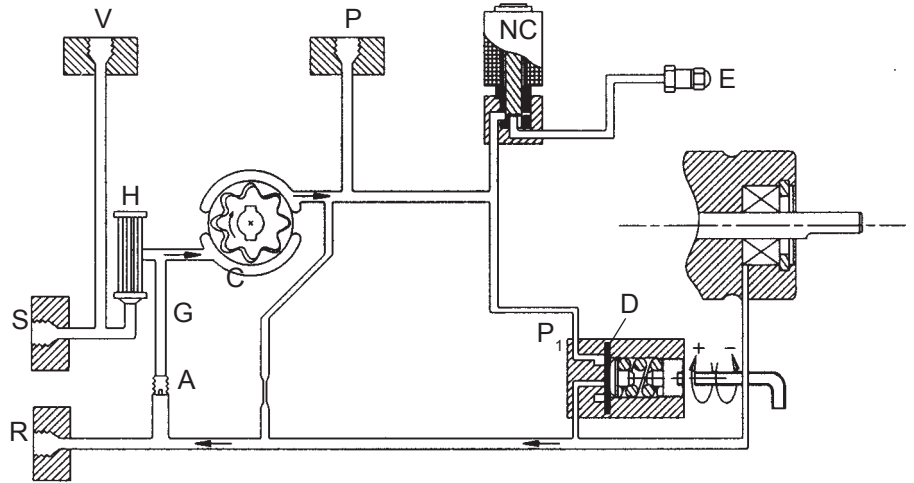

- The diaphragm and the spring keep the pump pressure constant at set value.
- If the pump is overloaded, i.e. If you try to get out more oil than the gear set can supply under existing circumstances, the oil pressure falls below the set value and the valve closes against

the return side (R) by means of the diaphragm (D) and goes into starting position.

This can be remedied by:

- Reducing the pump pressure.
- Reducing the oil quantity supplied by using a smaller nozzle.
- Using a pump with a larger capacity.

Replacement of cartridge filter

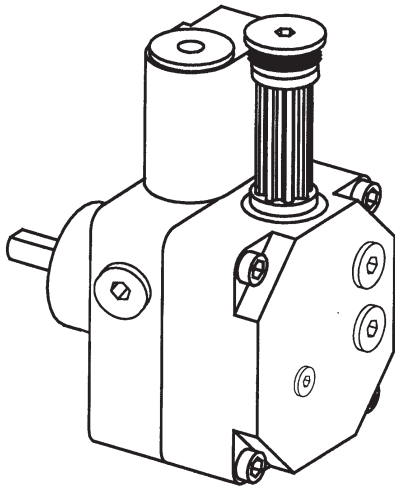

How to remove cartridge filter from plug

Unscrew the cartridge filter plug in the cover by means of a 4 mm allen key and withdraw the cartridge filter. If necessary, put a screwdriver between the cartridge filter and the plug and turn the cartridge filter carefully until it comes off. Reject the cartridge filter and replace it by a new one. Press it on to the plug. Ensure that the O-ring is not damaged. Then fit the new cartridge filter to the pump.

Mounting/dismounting return plug

One pipe system

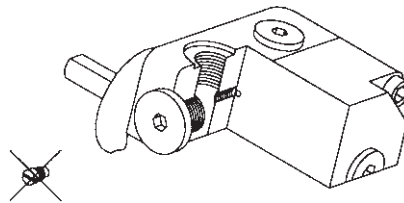

Two pipe system

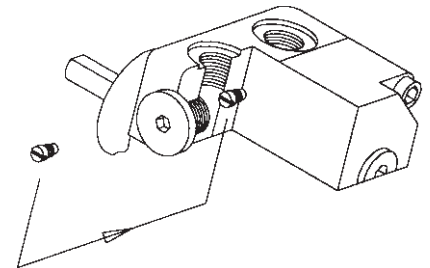

NOZZLE TABLE

Pump pressure bar

Gph	8			9			10			11		
	kg/h	kW	Mcal/h	kg/h	kW	Mcal/h	kg/h	kW	Mcal/h	kg/h	kW	Mcal/h
0,40	1,33	16	13	1,41	17	14	1,49	18	15	1,56	18	16
0,50	1,66	20	17	1,76	21	18	1,86	22	19	1,95	23	20
0,60	2,00	24	20	2,12	25	22	2,23	26	23	2,34	28	24
0,65	2,16	26	22	2,29	27	23	2,42	29	25	2,54	30	26
0,75	2,49	29	25	2,65	31	27	2,79	33	28	2,93	35	30
0,85	2,83	33	29	3,00	36	31	3,16	37	32	3,32	39	34
1,00	3,33	39	34	3,53	42	36	3,72	44	38	3,90	46	40
1,10	3,66	43	37	3,88	46	39	4,09	48	42	4,29	51	44
1,20	3,99	47	41	4,24	50	43	4,47	53	46	4,68	55	48
1,25	4,16	49	42	4,40	52	45	4,65	55	47	4,88	58	50
1,35	4,49	53	46	4,76	56	48	5,02	59	51	5,27	62	54
1,50	4,98	59	51	5,29	63	54	5,58	66	57	5,85	69	60
1,65	5,49	65	56	5,82	69	59	6,14	73	63	6,44	76	66
1,75	5,82	69	59	6,18	73	63	6,51	77	66	6,83	81	70
2,00	6,65	79	68	7,06	84	72	7,45	88	76	7,81	93	80
2,25	7,49	89	76	7,94	94	81	8,38	99	85	8,78	104	89
2,50	8,32	99	85	8,82	105	90	9,31	110	95	9,76	116	99
2,75	9,15	108	93	9,71	115	99	10,24	121	104	10,73	127	109
3,00	9,98	118	102	10,59	126	108	11,16	132	114	11,71	139	119
3,50	11,65	138	119	12,35	146	126	13,03	154	133	13,66	162	139
4,00	13,31	158	136	14,12	167	144	14,89	176	152	15,62	185	159
4,50	14,97	177	153	15,88	188	162	16,75	198	171	17,57	208	179
5,00	16,64	197	170	17,65	209	180	18,62	221	190	19,52	231	199
5,50	18,30	217	187	19,42	230	198	20,48	243	209	21,47	255	219
6,00	19,97	237	204	21,18	251	216	22,34	265	228	23,42	278	239
6,50	21,63	256	220	22,94	272	234	24,20	287	247	25,37	301	259
7,00	23,29	276	237	24,71	293	252	26,06	309	266	27,33	324	279
7,50	24,96	296	254	26,47	314	270	27,92	331	285	29,28	347	298
8,00	26,62	316	271	28,24	335	288	29,79	353	304	31,23	370	318
8,50	28,28	335	288	30,00	356	306	31,65	375	323	33,18	393	338
9,00	29,95	355	305	31,77	377	324	33,59	398	342	35,14	417	358

The table applies to oil with a viscosity of 4,4 mm²/s (cSt) with density 830 kg/m³.

Burner with preheater

Consider that on preheating the oil quantity is reduced by 5-20% depending on.

- Rise in temperature at the nozzle
- Design of nozzle
- Capacity (high capacity - small difference)

NOZZLE TABLE

Pump pressure bar

Gph	12			13			14			15		
	kg/h	kW	Mcal/h	kg/h	kW	Mcal/h	kg/h	kW	Mcal/h	kg/h	kW	Mcal/h
0,40	1,63	19	17	1,70	20	17	1,76	21	18	1,82	21	18
0,50	2,04	24	21	2,12	25	22	2,20	26	22	2,28	27	23
0,60	2,45	29	25	2,55	30	26	2,64	31	27	2,73	32	28
0,65	2,65	31	27	2,75	33	28	2,86	34	29	2,96	35	30
0,75	3,08	36	31	3,18	38	32	3,30	39	34	3,42	40	35
0,85	3,47	41	35	3,61	43	37	3,74	44	38	3,87	46	39
1,00	4,08	48	42	4,24	50	43	4,40	52	45	4,56	54	46
1,10	4,48	53	46	4,67	55	48	4,84	57	49	5,01	59	51
1,20	4,89	58	50	5,09	60	52	5,29	63	54	5,47	65	56
1,25	5,10	60	52	5,30	63	54	5,51	65	56	5,70	68	58
1,35	5,50	65	56	5,73	68	58	5,95	70	61	6,15	73	63
1,50	6,11	72	62	6,36	75	65	6,60	78	67	6,83	81	70
1,65	6,73	80	69	7,00	83	71	7,27	86	74	7,52	89	77
1,75	7,14	85	73	7,42	88	76	7,71	91	79	7,97	94	81
2,00	8,18	97	83	8,49	101	86	8,81	104	90	9,12	108	93
2,25	9,18	109	94	9,55	113	97	9,91	117	101	10,26	122	105
2,50	10,19	121	104	10,61	126	108	11,01	130	112	11,39	135	116
2,75	11,21	133	114	11,67	138	119	12,11	144	123	12,53	148	128
3,00	12,23	145	125	12,73	151	130	13,21	157	135	13,67	162	139
3,50	14,27	169	145	14,85	176	151	15,42	183	157	15,95	189	163
4,00	16,31	193	166	16,97	201	173	17,62	209	180	18,23	216	186
4,50	18,35	217	187	19,10	226	195	19,82	235	202	20,51	243	209
5,00	20,39	242	208	21,22	251	216	22,03	261	225	22,79	270	232
5,50	22,43	266	229	23,34	277	238	24,23	287	247	25,07	297	256
6,00	24,47	290	249	25,46	302	260	26,43	313	269	27,49	326	280
6,50	26,51	314	270	27,58	327	281	28,63	339	292	29,63	351	302
7,00	28,55	338	291	29,70	352	303	30,84	366	314	31,91	378	325
7,50	30,59	363	312	31,83	377	324	33,04	392	337	34,19	405	349
8,00	32,63	387	333	33,95	403	346	35,25	418	359	36,47	432	372
8,50	34,66	411	353	36,07	428	368	37,45	444	382	38,74	459	395
9,00	36,71	435	374	38,19	453	389	39,65	470	404	41,02	486	418

The table applies to oil with a viscosity of 4,4 mm²/s (cSt) with density 830 kg/m³.

Burner with preheater

Consider that on preheating the oil quantity is reduced by 5-20% depending on.

- Rise in temperature at the nozzle
- Design of nozzle
- Capacity (high capacity - small difference)

FAULT LOCATION

Burner fails to start

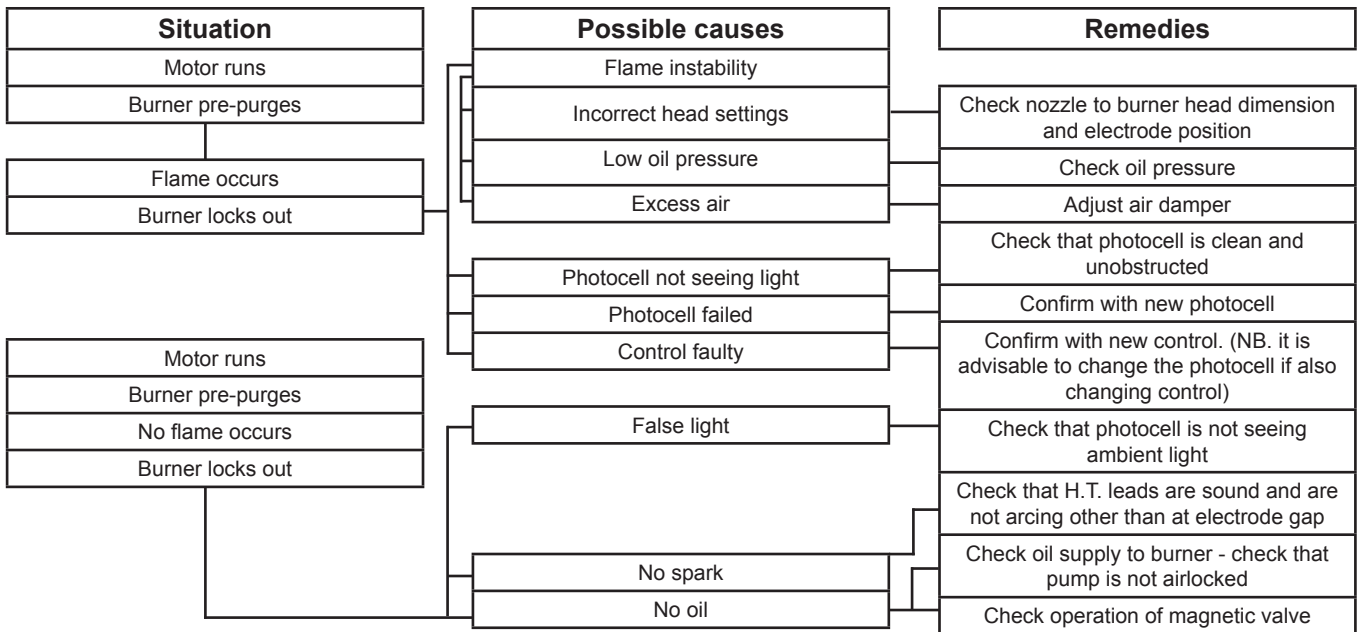

Burner fails to start after normal operation

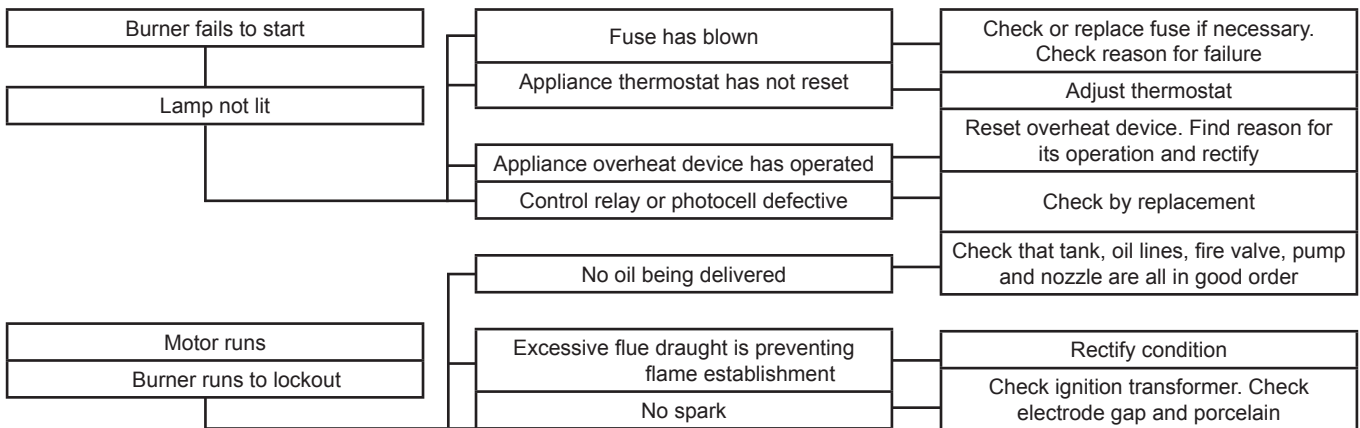

Delayed ignition, burners starts violently

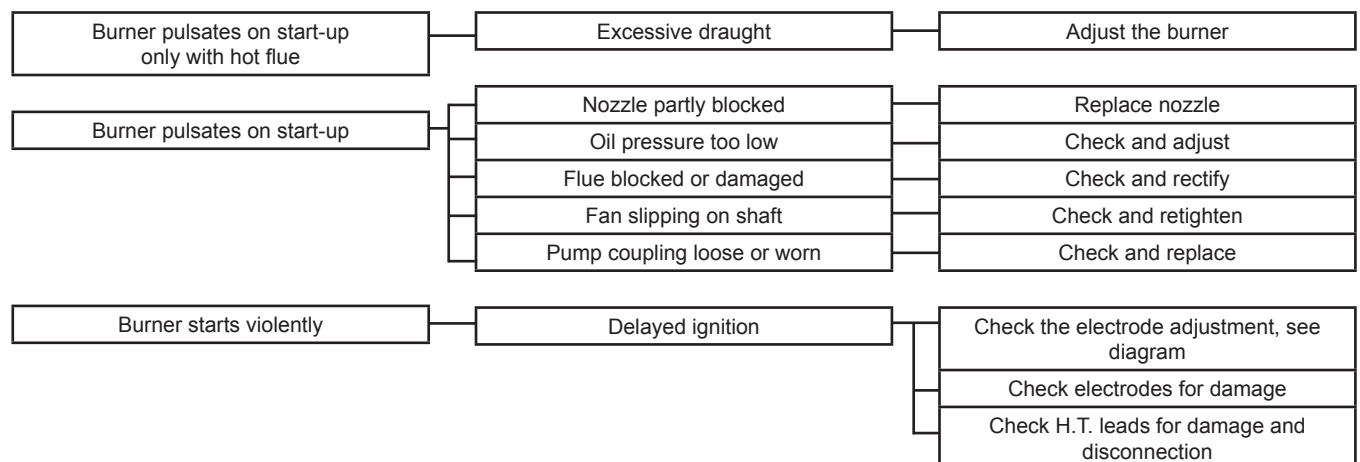

OIL BURNERS MAINTENANCE INSTRUCTIONS

General information

Keep the boiler room clean. Ensure that the boiler room has permanent fresh air intake. Switch off before dismantling the oil burner.

At hinged mounting, make sure that an automatic safety switch is fitted, so that the burner cannot start when the swing door is open.

Don't use the oil fired boiler to burn paper or rubbish, unless the boiler is especially fitted with a hinged door to make this possible.

Don't fill tank while burner is working.

Starting precautions

Make sure that the oil tank is not empty

Make sure that the valves on oil and water supply pipes are open.

Make sure that the boiler flue damper is open.

Make sure that the boiler thermostat is set at the correct temperature.

Switch on the current. Most relay systems have a delayed action so that the burner will not start for perhaps 20 seconds.

With heavy oil the delay will be longer as the burner will not start until the oil in the preheater reaches the required temperature.

If the burner will not start

Press the reset button on the relay. Check that the thermostats are correctly adjusted.

Don't forget the room thermostat, check that any fuses are intact and main switch is on.

Installed by:

.....

Tel:

If the burner starts but does not ignite

Make an attempt to start the burner.

Never make close repeated start attempts.

Don't restart the burner until the boiler is free from oil gases.

If the burner still does not ignite send for the service engineer.

When switching off during summer

Always use the main switch to cut out the burner even when adjusting the burner or cutting off the heating for a short time. For longer periods of shut down, close all valves and the oil supply stop-cock.

Clean the filter and nozzle by washing in petrol or paraffin.

Make sure the filter medium is not damaged or defective.

Protect electrical gear from damp.

Warning

Never stand too near or put your face to the inspection or fire door, when the burner is about to start.

Never use a naked flame to ignite oil if the electrical ignition fails.

Always wait for about 10 minutes for the unburnt gases to disperse before restarting the oil burner if it has failed to ignite previously.

