

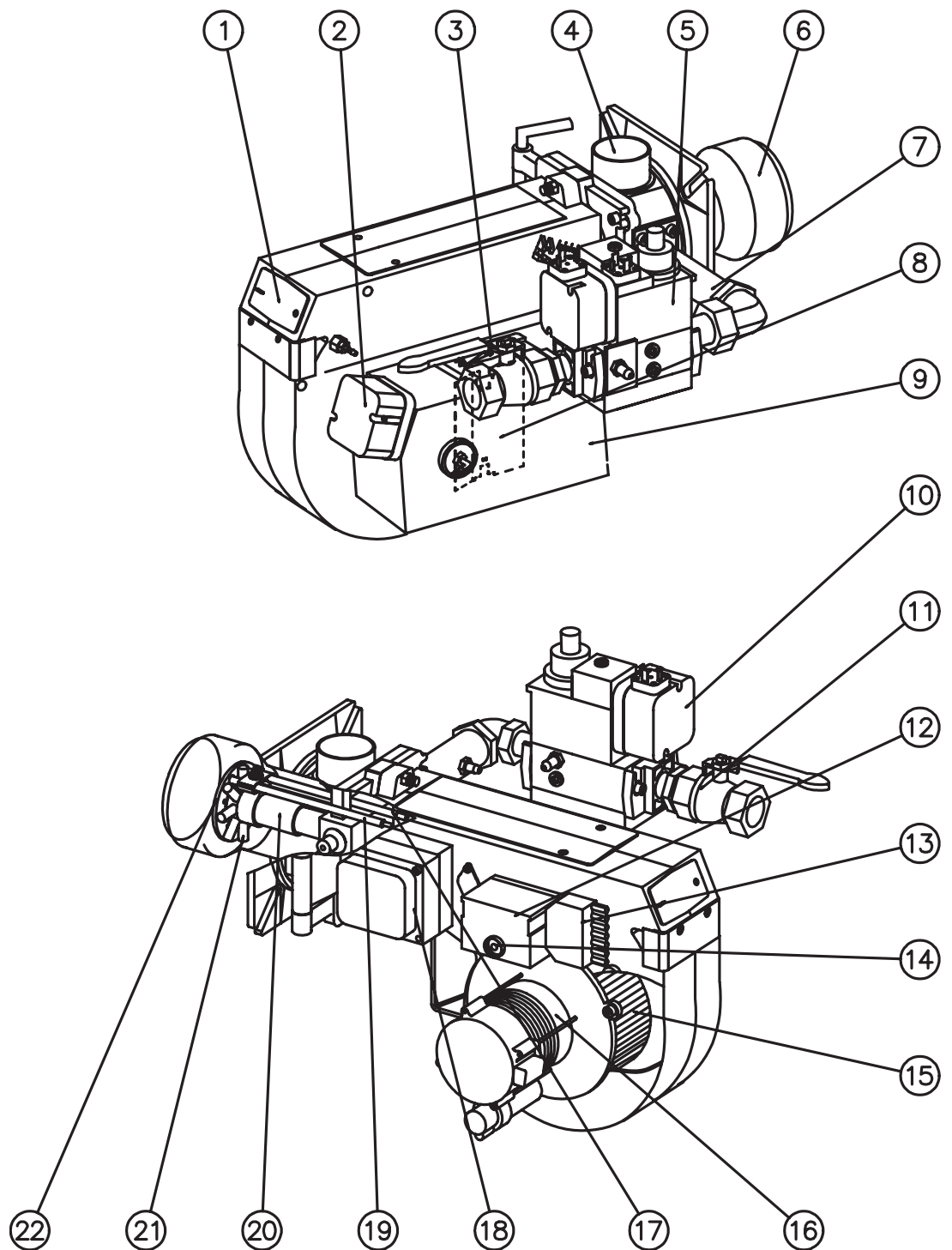

Providing sustainable energy solutions worldwide

Installation- and maintenance instruction
MGN320 S1L 355

DESCRIPTION



Components

- | | | |
|--|---------------------------|--------------------------|
| 1. Cover,inspection glass | 8. Air dampe | 16. Motor |
| 2. Air pressure switch | 9. Air intake | 17. Ignition electrode |
| 3. Air adjustment | 10. Gas pressure switch | 18. Transformer |
| 4. Inner assembly adjustment
(not town gas) | 11. Ball valve | 19. Ionization electrode |
| 5. Multibloc | 12. Control box | 20. Inner assembly |
| 6. Flame cone | 13. Electrical connection | 21. Nozzle |
| 7. Connecting pipe | 14. Reset button | 22. Brake plate |
| | 15. Fan wheel | |

TECHNICAL DATA

Type designation BG 400 Dimensions

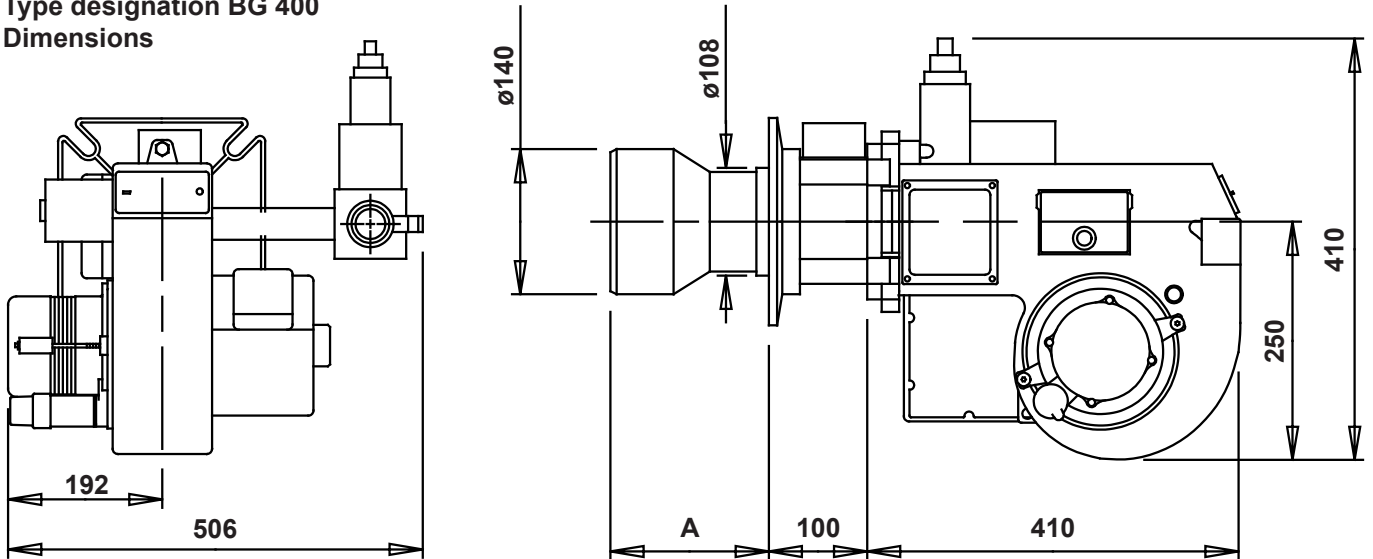

	Length of burner tube	Measure A
Standard	172	155
	272	255
Long design	372	355

The above dimensions are max. measurements. Depending on the components used, the measurements may vary.

Output range

Type	Capacity kW	Gas volume at a min. output Nm ³ /h ¹⁾		Gas volume at a max. output Nm ³ /h ¹⁾		Max. inlet pressure mbar	Rated inlet pressure mbar	
		Natural gas	LPG	Natural gas	LPG		Natural gas	LPG
400	60-318	6	2,3 (5,0 kg/h)	31,8	12,2 (24,8 kg/h)	100	20	20
		²⁾ Town gas	²⁾ Town gas	²⁾ Town gas	²⁾ Town gas		²⁾ Town gas	²⁾ Town gas

Gas fittings ²⁾	Motor	Ignition transformer
Natural gas, LPG 1"	1-phase, 0,25 kW, 2 800 r/m, 230 V	Primary 230 V, 1, A Secondary 8 000 V
²⁾ Town gas		

¹⁾ Calorific value:
Natural gas 10 kWh/Nm³
LPG 26 kWh/Nm³

²⁾ Dimension and capacity depending on gas quality and available pressure

Capacity chart according to EN 676

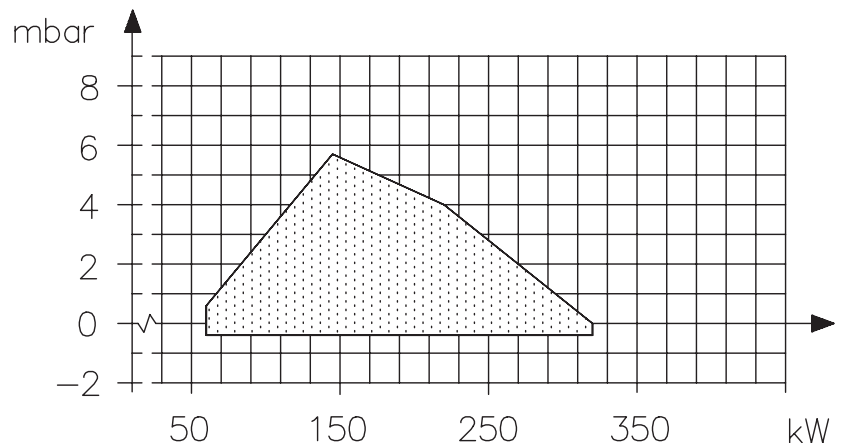

TECHNICAL DATA

Dimensions of flange

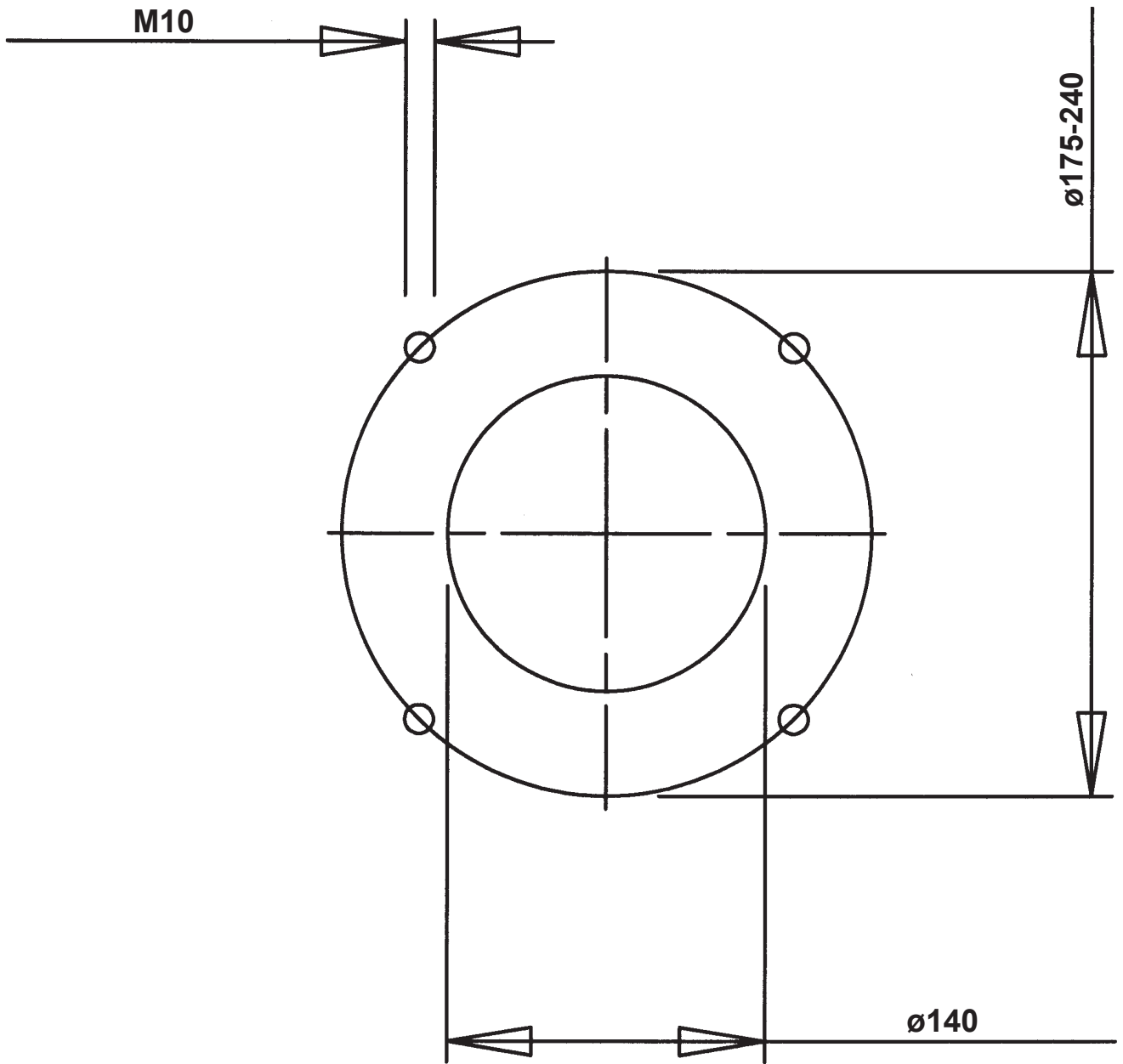

SKELETON DIAGRAMS, 1-STAGE BURNER

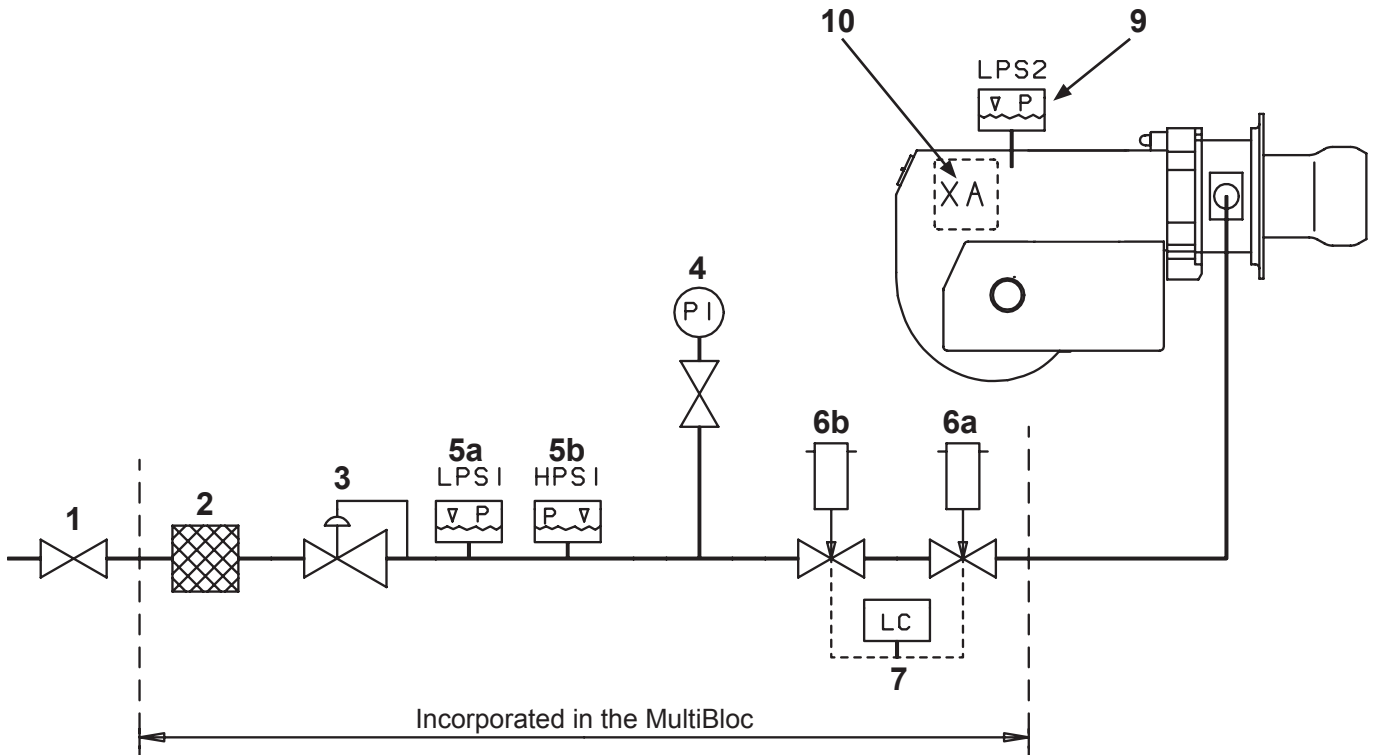

- 1. Ball valve
- 2. Filter
- 3. Governor
- 4. Pressure gauge with shut-off cock
- 5a. Gas pressure switch, mini
- 5b. Gas pressure switch, maxi

- 6a. Main valve
- 6b. Safety valve
- ¹⁾7. Valve proving system
- 9. Air pressure switch
- 10. Gas burner control

Pos. 5b, 7: Components not required according to EN 676.

¹⁾ Required over 1200 kW according to EN 676.



When Bio gas is used, Bentone shall always be contacted.

MOUNTING ON THE BOILER

Remove the combustion unit from the burner. Fit the enclosed flange and gasket to the boiler. If new fixing holes must be drilled, use the fixing flange as a pattern.

Removal of valve unit from burner

Remove the plug-in contact from the multi-bloc. Loosen the union nut.

Removal of fan house unit from burner.

Loosen the screws. Swing out the fan house. Remove the ionisation and ignition cables from the electrodes. Remove the bolt on the flange.

Installation example

Connect the gas to the burner by means of the ball valve. Ensure that the union nut, ball valve and tubing make it easy to remove the burner for inspection and service.

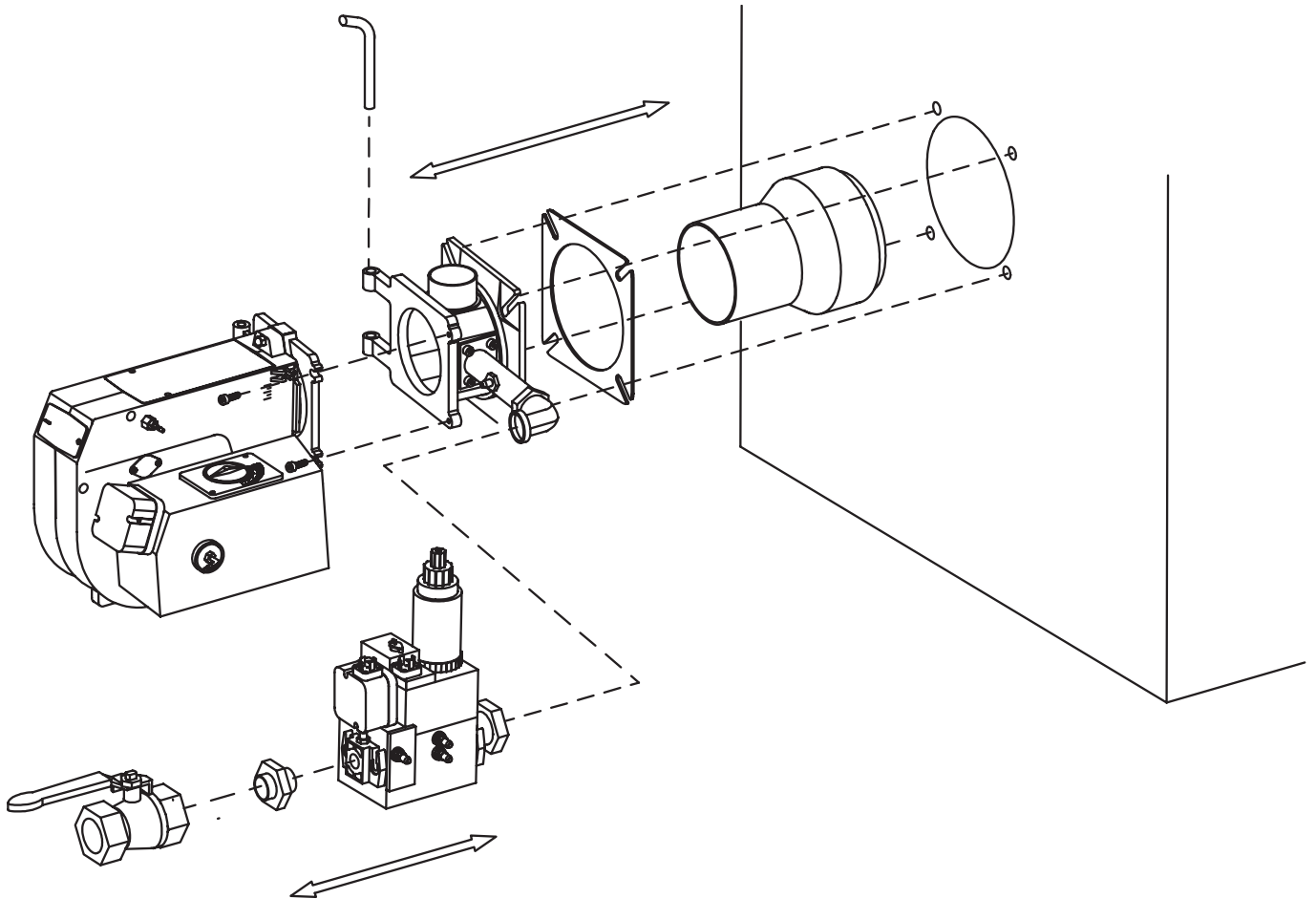

ELECTRIC EQUIPMENT

Gas burner control: LGB21/LMG21/LME11/LME21 Wiring diagram

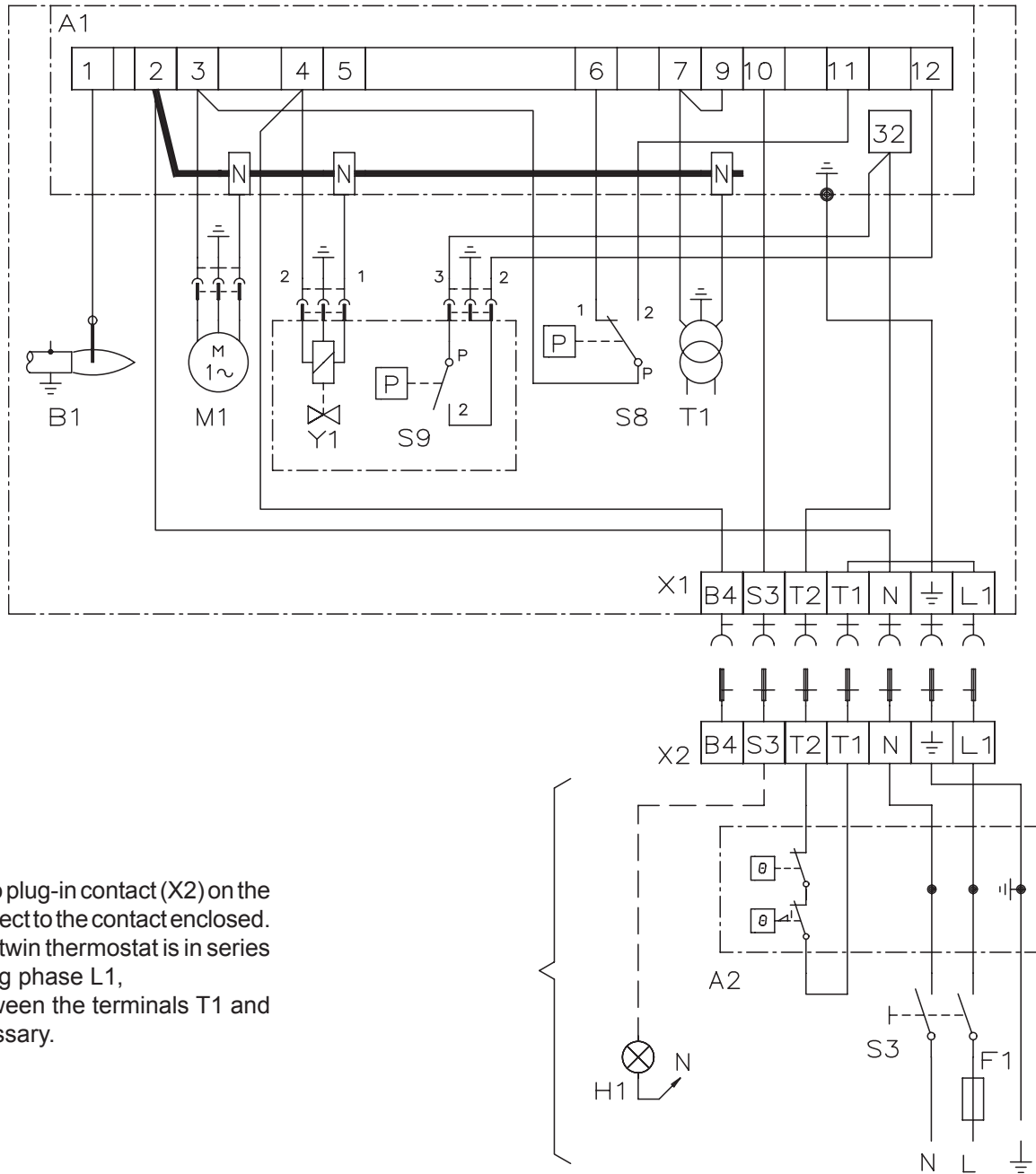

If there is no plug-in contact (X2) on the boiler, connect to the contact enclosed. In case the twin thermostat is in series on incoming phase L1, a loop between the terminals T1 and T2 is necessary.

Component list

A1 Gas burner control
A2 Twin thermostat
B1 Ionization electrode
F1 Fuse
H1 Alarm, 230 V

M1 Burner motor
S3 Main switch
S8 Air pressure switch
S9 Gas pressure switch
T1 Ignition transformer

X1 Plug-in contact, burner
X2 Plug-in contact, boiler
Y1 Gas solenoid valve

ELECTRIC EQUIPMENT

Control diagnosis under fault conditions and lockout indication

Gas burner control: LGB

Lock-out and Control Programme Indication

The position of the cam can be read through the sight-glass. Under fault condition the programme is stopped and thus also the lock-out indicator. The symbol visible on the cam indicates both the position in the programme run and the type of fault. The symbols are explained below:

- ◀ No start because the control loop is interrupted
- ||||| Waiting for the pre-purge to start
- ▲ Air damper open (LGB22)
- P Fault condition due to absence of air pressure signal (LGB21), air damper not open (LGB22)
- ←←← Pre-purge period
- ▼ Fuel release (LGB22)
- 1 Fault condition because no flame signal available after elapse of the 1st safety time
- 2 Release of the 2nd fuel valve (LGB21)
Release of the load controller LR (LGB22)
- Partial or full load operation (or return to the operating position)

Control Programme in Case of Faults

Basically, the fuel supply is stopped immediately in the case of any fault. If the fault condition occurs at a time between start and pre-ignition, which is not indicated by symbols, the cause is usually a switch-off by the air pressure switch LP or a too early, i.e. faulty, flame signal.

- **After supply voltage failure:** Start-up repetition with unabridged programme.
- **If premature flame signal** at start of pre-purge time: Immediate lock-out.
- **If contacts of air pressure switch LP have welded during tw:** No start.
- **If no air pressure signal:** Lock-out when t10 has elapsed.
- **If air pressure failure** after elapse of t10: Immediate lock-out.
- **If burner does not ignite:** Lock-out when safety time t2 has elapsed.
- **If flame is lost during operation:** Immediate lock-out.
- **For ignition spark proving with QRE:** If no ignition spark signal, the valves remain closed and there is lock-out when t2 has elapsed.

Resetting the burner controls

The controls can be reset immediately after any fault condition. The programme reverts to its start position and programmes the controls for restarting the burners.

Connecting signal amplifier

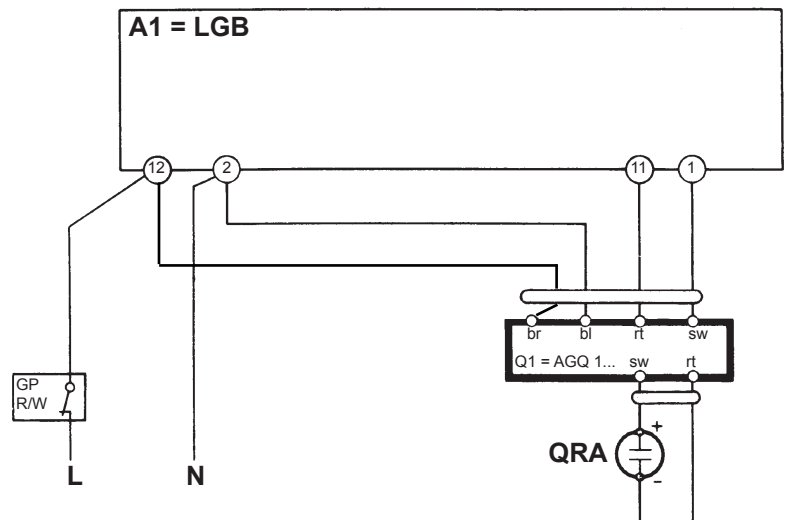

ELECTRIC EQUIPMENT

Control diagnosis under fault conditions and lockout indication

Gas burner control: LMG ...

Diagnosis of cause of fault

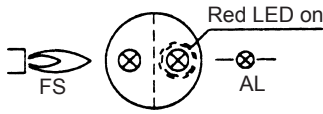

After lockout, the red fault LED is steady on. For reading the cause of fault, refer to the blink code given in the following table:

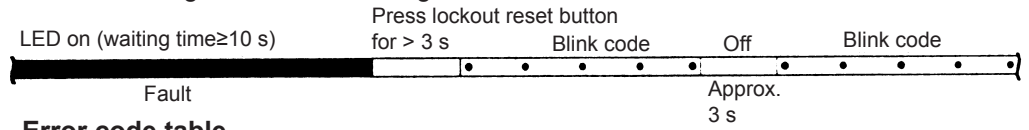

Error code table

Blink code	Possible cause
2 x ••	<ul style="list-style-type: none"> No establishment of flame at the end of «TSA» – Fault or soiled detector electrode – Fault or soiled fuel valves – Poor adjustment of burner
3 x •••	<ul style="list-style-type: none"> Air pressure monitor does not close – «LP» faulty – «LP» incorrectly adjusted – Fan motor does not run
4 x ••••	<ul style="list-style-type: none"> Air pressure monitor does not open or extraneous light on burner startup – «LP» faulty – «LP» incorrectly adjusted
5 x •••••	<ul style="list-style-type: none"> Extraneous light during pre-purging – Or internal device fault
7 x •••••••	<ul style="list-style-type: none"> Loss of flame during operation – Poor adjustment of burner – Faulty or soiled fuel valves – Short-circuit between detector electrode and ground
8...17 x ••••••• ••••••• •••••••	<ul style="list-style-type: none"> Free
18 x •••••••• ••••••••	<ul style="list-style-type: none"> Air pressure monitor opens during pre-purging or operation – «LP» correctly adjusted – Four times loss of flame during operation (LMG25)
19 x •••••••• ••••••••	<ul style="list-style-type: none"> Faulty output contact – Wiring error – External power supply on output terminal
20 x •••••••• ••••••••	<ul style="list-style-type: none"> Internal device fault

During the time the cause of the fault is diagnosed, the control outputs are deactivated.

- The burner remains shut down
- Exception: fault status signal «AL» at terminal 10

The burner is switched on only after a reset is made.

- Press lockout reset button for 0.5...3 seconds

Connecting signal amplifier

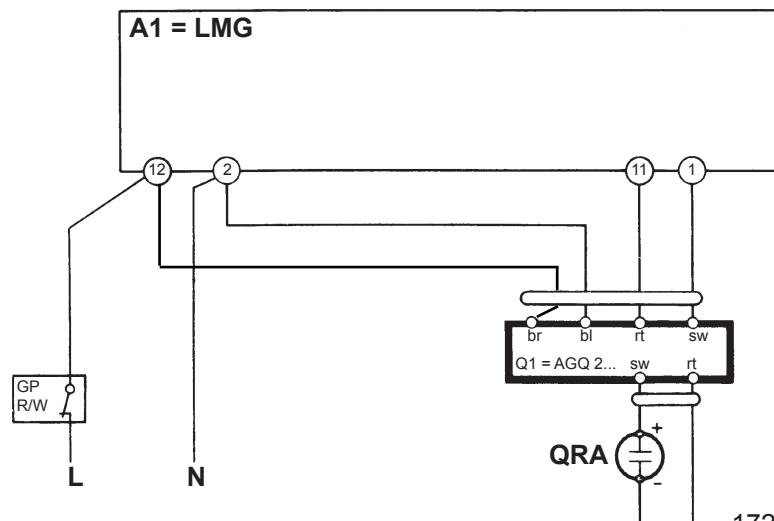

ELECTRIC EQUIPMENT

Control diagnosis under fault conditions and lockout indication

Gas burner control: LME...

Colour codes

Colour code table for multi-coloured signal lamps (Light diodes)		
Status	Colour codes	Colours
Waiting time «tw», other waiting times	○.....	Off
Ignition phase, ignition checked	●○●○●○●○●○●○	Flashing yellow
Normal operation	□.....	Green
Operation, poor flame signal	□○□○□○□○□○□○	Flashing green
Prohibited flame signal during start up	□▲□▲□▲□▲□▲□▲	Green-Red
Undervoltage	●▲●▲●▲●▲●▲●▲	Yellow-Red
Disruption, alarm	▲.....	Red
Flashing code for fault codes	▲○▲○▲○▲○▲○▲○	Flashing red
Interface diagnostics	▲▲▲▲▲▲▲▲▲▲	Red flickering

..... Continuous ▲ Red
 ○ Off ● Yellow
 □ Green

Diagnostics alarm trigger

The red alarm signal lamp lights continuously after the alarm is disconnected.
 Diagnostics for alarm triggers can be read as specified by the following sequence:

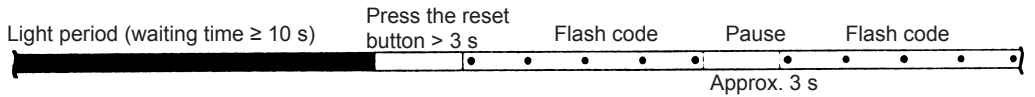
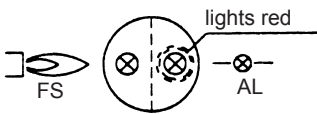

Limit on start attempts

LME 11 ... limits the number of start attempts if the flame does not ignite on start-up or goes out during operation. LME 11 ... permits a maximum of three start attempts if the start cycle is uninterrupted.

ELECTRIC EQUIPMENT

Control diagnosis under fault conditions and lockout indication

Gas burner control: LME...

Alarm control table

Red flashing code on signal lamp (LED)	Possible causes
Flashing 2 x ••	<ul style="list-style-type: none"> • No flame at End of «TSA» – Defective or obscured flame monitor – Defective or obscured fuel valves – Poor burner installation – Defective ignition unit
Flashing 3 x •••	«LP» defective <ul style="list-style-type: none"> – No air monitor signal after «t10» – «LP» is welded in the open position
Flashing 4 x ••••	Prohibited flame signal during start up
Flashing 5 x •••••	Time out «LP» <ul style="list-style-type: none"> – «LP» is welded in the closed position
Flashing 6 x ••••••	Free
Flashing 7 x •••••••	Too many loss of flame during operation <ul style="list-style-type: none"> – Poor burner installation – Defective or obscured fuel valves – Defective or obscured flame monitor
Flashing 8 x ••••••••	Free
Flashing 9 x •••••••••	Free
Flashing 10 x ••••••••••	Connections fault or internal fault, outgoing contacts or other fault
Flashing 14 x •••••••••• •••••	CPI contact not closed

During alarm trigger diagnostics, control outputs are to be disconnected from all power.

- The burner is disconnected
- Exception, the «AL» alarm signal at connection block 10
- The burner is only to be reconnected after it is reset
- Press the reset button 0.5...3 s

Interface diagnostics

To switch to interface mode, hold the reset button depressed for more than 3 s. To return to normal mode, hold the reset button depressed for more than 3 s. If the firing unit is in the alarm mode, it is reset by pressing the reset button 0.5...3 s.

Connecting signal amplifier

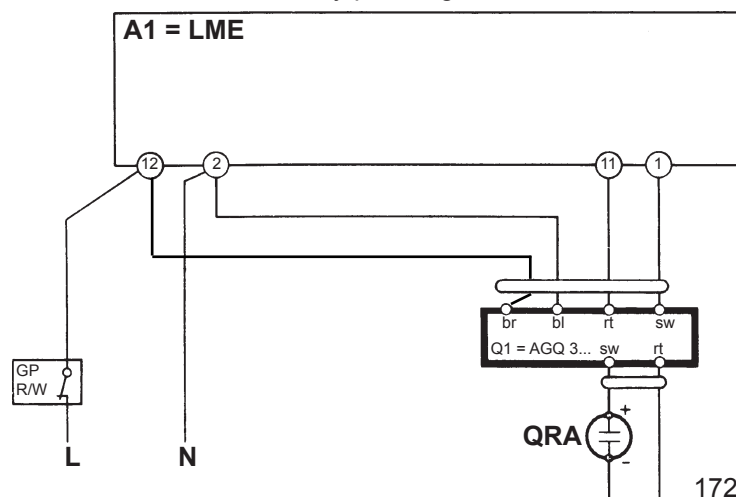

MEASURES AND CHECKS BEFORE START-UP, 1-STAGE BURNER

General rules

Care should be taken by the installer to ensure that no electrical cables or fuel/gas pipes are trapped or damaged during installation or service/maintenance.

Inner assembly

Ensure that the ignition and ionisation electrodes are correctly adjusted. The sketch shows the correct measurements.

Gas quality

Ensure that the burner head is meant for the gas quality to be used (see fig.)

Venting

The gas line is vented by loosening the screw on the test nipple for the inlet pressure. Connect a plastic hose and conduct the gas into the open. **After having vented the gas line tighten the screw again.**

Leakage control

When making a leakage control of the gas supply system the solenoid valve should be closed. Connect a pressure gauge to the test nipple Pa, see fig. The test pressure in the system should be 1,5x max. inlet pressure or min. 150 mbar. If any leakage, locate the source by means of soapy water or a leak location spray. After tightening repeat the test.

Electric function test:

Ensure that phase and neutral are not reversed. The gas shut-off cock should be closed. To prevent the gas pressure switch from locking out it should be linked temporarily.

After the main switch has been switched on and the thermostats have been adjusted the pre-purging period begins (30-35sec.). At the end of this period the pre-ignition period starts

(0,5-2,5 sec. dependent on the design of the gas control). The gas valve is energized and opens and flame is established. At the end of the safety time (2-3 sec.) the gas control locks out. The solenoid valve and the motor will be "dead". Remove the link from the gas pressure switch after the test is finished.

NOTE! Applies only to gas burner control LFL1.

When using LPG (Propane) the burner should be connected for post-purge. Move connection to terminal 6 to terminal 7 in the base of LFL1.

Leakage control

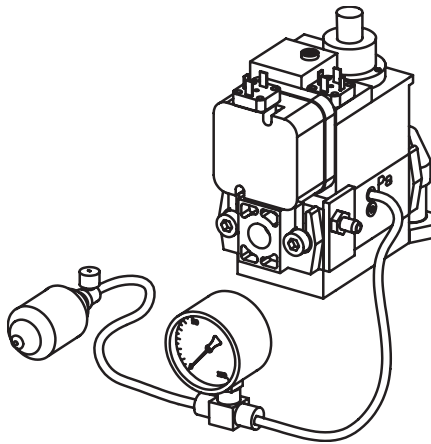

MEASURES AND CHECKS BEFORE START-UP

INNER ASSEMBLY

Town gas

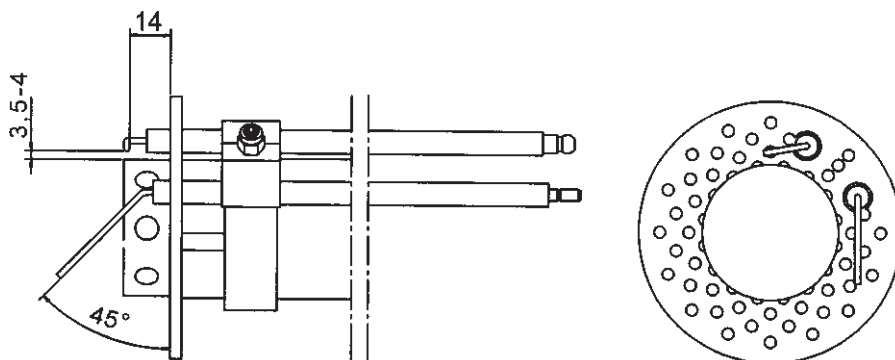

INNER ASSEMBLY

Natural gas, LPG

LPG

Natural gas

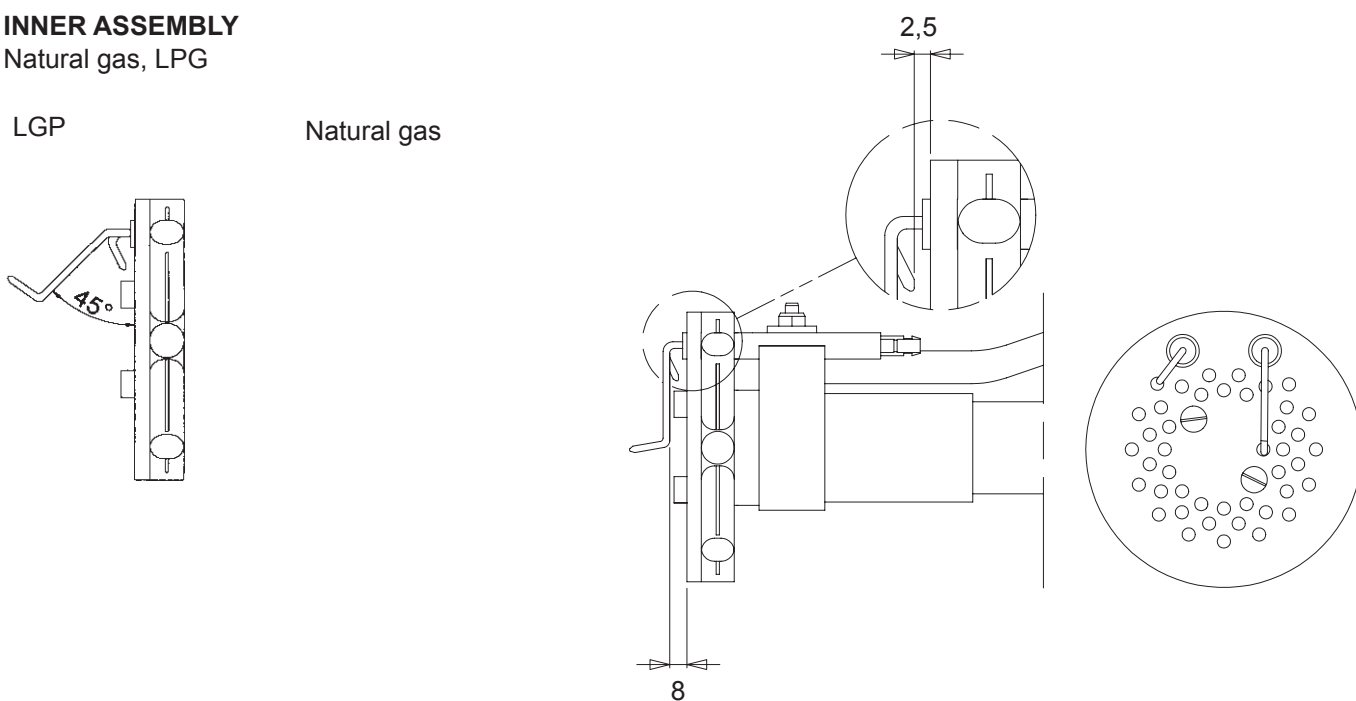

INNER ASSEMBLY

Biogas (UV-detector)

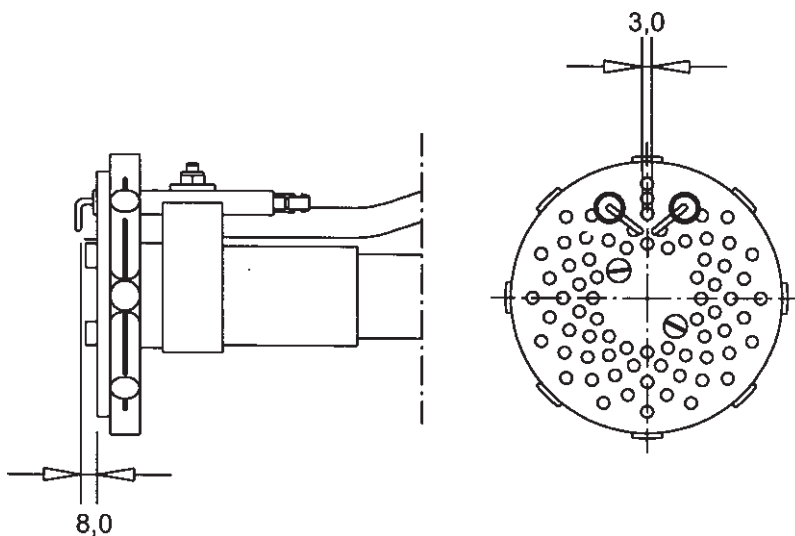

DETERMINATION OF GAS VOLUME FOR THE INSTALLATION

Specifications on natural gas, town gas and bio gas vary. For more exact information please contact the gas distributor.

Gas quality	Net calorific value		
	kWh/Nm ³	kJ/Nm ³	kcal/Nm ³
Natural gas	10,3	37 144	8 865
Propane	26,0	93 647	22 350
Butane	34,3	123 571	29 492
Town gas	4,9	17 653	4 213
Bio gas	7,0	25 219	6 019

Example how to calculate the gas volume (natural gas)

V = Gas volume Nm³/h

Q = Boiler output 120 kW

H_u = Calorific value of the gas A. 37 144 kJ/Nm³, B. 10.3 kWh/Nm³

η = Expected efficiency 90%

$$\text{Ex. A } v = \frac{Q \cdot 3\,600}{H_u \cdot \eta} = \frac{120 \cdot 3\,600}{37\,144 \cdot 0,90} \approx 12,9 \text{ Nm}^3/\text{h}$$

$$\text{Ex. B } v = \frac{120}{10,3 \cdot 0,90} \approx 12,9 \text{ Nm}^3/\text{h}$$

If the barometer height, pressure and temperature of the gas deviate very much from the normal values this must be taken into account as follows:

$$f = \frac{273+t}{273} \cdot \frac{1013,25}{B+P_u}$$

t = Temperature of the gas at the gas meter (15°C)

B = Barometer height (945 mbar)

P_u = Pressure of the gas at the gas meter (15,0 mbar)

$$f = \frac{273+15}{273} \cdot \frac{1013,25}{945+15}$$

$$f = 11,1$$

The gas volume read on the gas meter actually reads $1,11 \cdot 12,9 = 14,4 \text{ m}^3/\text{h}$.

ADJUSTMENT OF MULTI-BLOC, MB-DLE 405-420

Max. inlet pressure: 360 mbar.

Adjustable governor pressure:

405 - 412 S50 = 4 - 50 mbar

415 - 420 S20 = 4 - 20 mbar

415 - 420 S50 = 20 - 50 mbar

Solenoid valve: Slow opening valves with adjustable start load and max. flow.

1. Protective cover start load adjustment
2. Hydraulic damping
3. Fixing screw
4. Test nipple (inlet pressure)
5. Test nipple (pressure after governor)
6. Test nipple (pressure in inner assembly)
7. Governor
8. Filter
9. Gas pressure switch
10. Solenoid valve

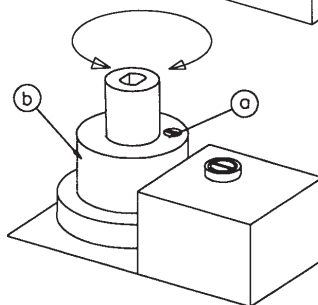
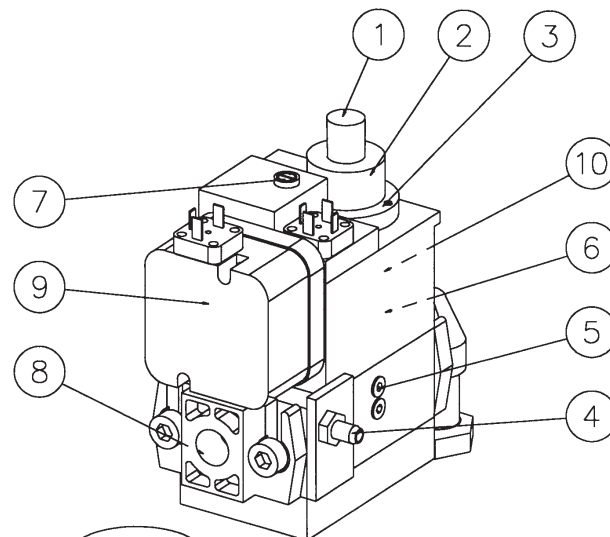

Flow adjustment

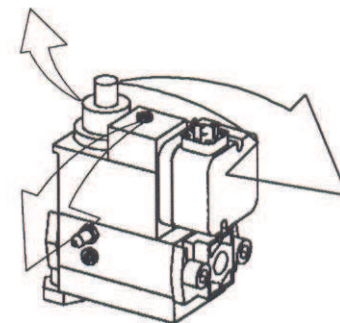

Flow adjustment

Loosen the fixing screw a. Turn the hydraulic device b:

to the right = the gas flow is reduced

to the left = the gas flow is increased

Do not forget to tighten the fixing screw again.

The flow adjustment can also be made by means of the governor. Adjust the outlet pressure to a value giving the desired gas flow on the fully open valve. At small capacities (gas flows) it is also necessary to adjust as above.

Adjustment of governor

Adjust outlet pressure from governor by means of a screw. Min. and max. outlet pressures corresponds to appr. 60 turns of the spring. It is not possible to change pressure springs in order to change the outlet pressure.

Turn to the right = the outlet pressure is increased

Turn to the left = the outlet pressure is reduced

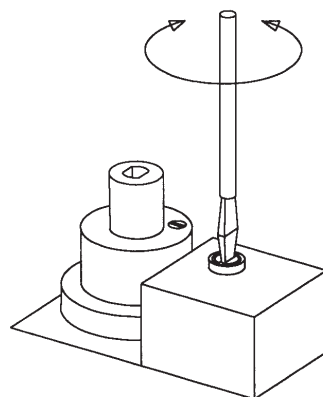

Adjustment of governor

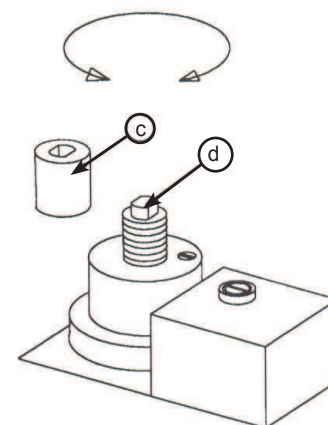

Adjustment of start gas flow

Adjustment of start gas flow

Remove the protective cover c.

Turn the adjustment knob d (use the protective cover as a tool) to the desired start gas flow.

Turn to the right = the start gas flow is reduced

Turn to the left = the start gas flow is increased

GENERAL INSTRUCTIONS

Adjustment of burner

The burner is from the factory pre-set to an average value that must then be adjusted to the boiler in question.

All burner adjustments must be made in accordance with boiler manufacturers instructions. These must include the checking of flue gas temperatures, average water temperature and CO₂ or O₂ concentration.

General instructions

The installation of the gas burner must be carried out in accordance with current regulations and standards. The installers of gas burners should therefore be acquainted with all regulations and ensure that the installation complies with the requirements. The installation, mounting and adjustment should be made with the greatest care and only the correct gas should be used.

Operating instructions

The operating instructions accompanying the burner should be left in a prominent position in the boiler room.

Instructions

The user should be thoroughly instructed in the function of the gas burner and the whole installation. The supplier must instruct the user.

Inspection and maintenance

Daily inspection is advisable.

Start up

After the burner has been fitted to the boiler and the electric connection, the leakage control, the venting and the electric function test have been carried out, the burner will be ready for start-up.

However, study the sections dealing with adjustments of multi-bloc, combustion air and combustion head. Open the ball valve and switch on the main switch. If the burner starts the actual adjustment can be made.

Adjustment of burner head

The burner is equipped with an adjustment device changing the position of the brake plate in the burner head. This is used to adjust the correct pressure drop over the combustion device in order to obtain a good pulsation free combustion.

Which position to use depends on input and overpressure in the boiler.

A general rule is that the lower capacity the smaller the opening between brake plate and combustion device.

Commissioning of installation

Control of the combustion. The combustion quality is checked by means of a flue gas analysis device. Adjust the burner to appr. 20% excess air in accordance with the table. Check the flue gas temperature. Calculate the efficiency. Check also the actual gas volume on the gas meter so that the correct input is achieved.

Service

Service should only be carried out by qualified personnel. Replacement parts should be of the same make and approved by the same authorities as the original. If the burner is converted to fire another gas quality it must be re-commissioned. If town gas is to be fired the combustion head must be converted and the gas train adjusted to suit (e.g. a larger gas armature or a different spring in the governor may be required).

Gas quality	CO ₂ % lambda 1,2	O ₂ %	max. CO ₂ %
Natural gas	10,0	3,5	11,9
LPG	11,5	3,5	13,9

GENERAL INSTRUCTIONS, 1-STAGE BURNER

Air adjustment

Loosen the stop screw and turn the knob along the scale to the desired position and tighten the screw. Check the air adjustment by making a flue gas analysis.

Adjustment of brake plate

- Loosen the screw on the adjustment device.
- To reduce the opening: turn the knob to the left.
- To increase the opening: turn the knob to the right.

The adjustment of the position of the brake plate affects the air flow. It is therefore always necessary to make a fine adjustment of the air by means of the adjustment device of the burner.

Control of burner head

To check the burner head, brake plate and electrodes proceed as follows: Loosen the nuts a. Swing out the burner. Remove the screw b and the knob for adjustment of burner head. Loosen the screw c so much so that the inner assembly can be pulled out.

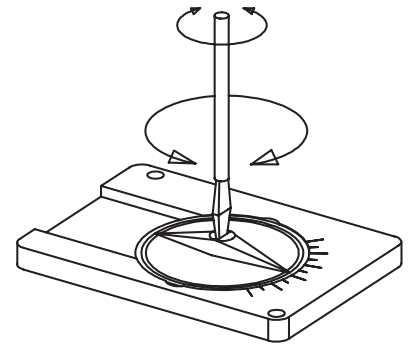

Air adjustment

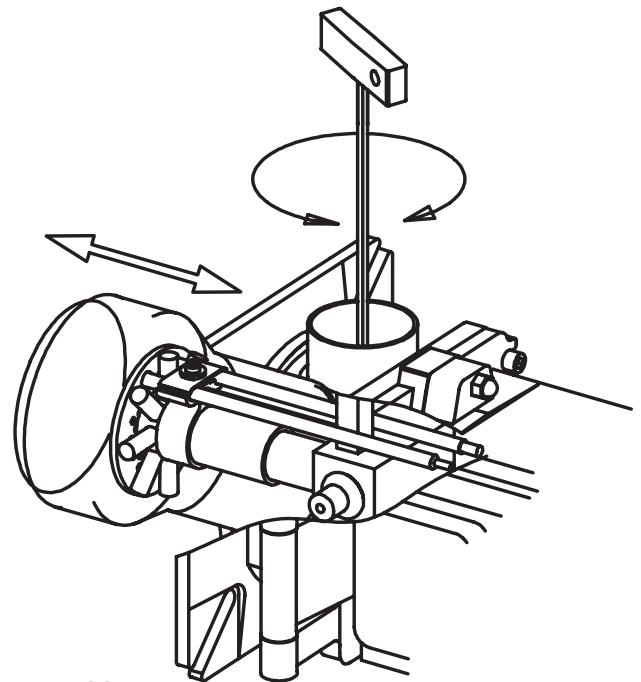

Adjustment of inner assembly

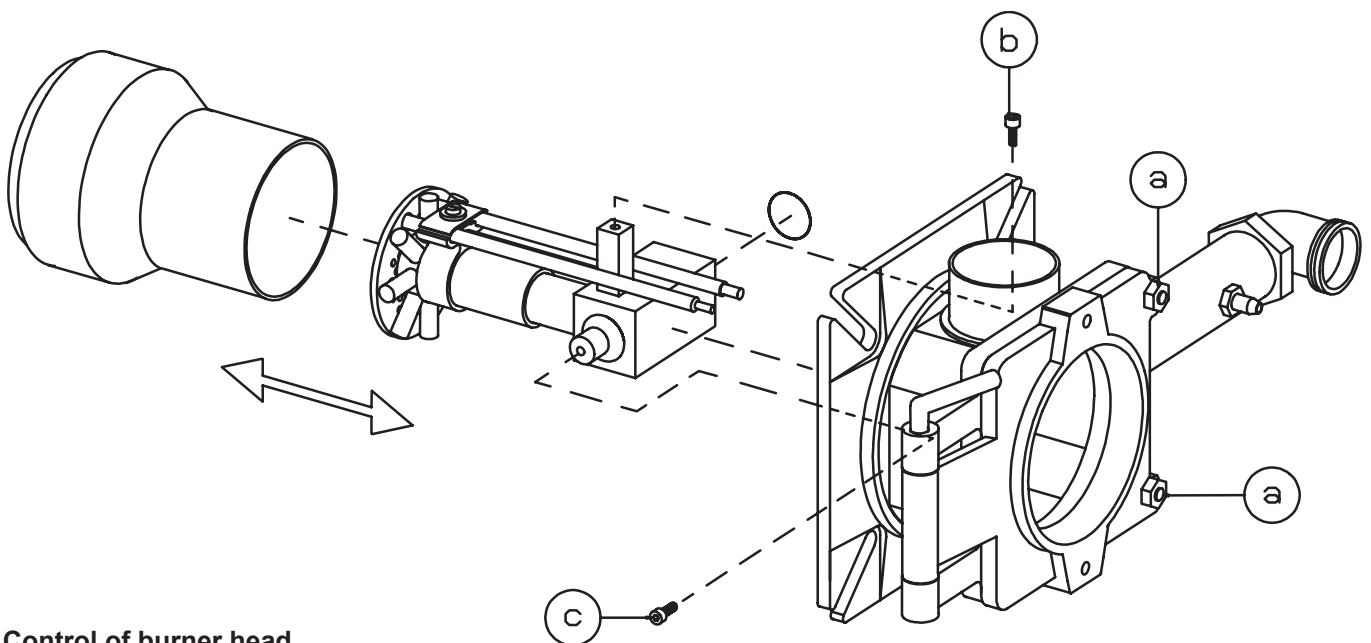

Control of burner head

GENERAL INSTRUCTION

Flame monitoring and measurement of ionisation current

The burner is monitored according to the ionisation principle. Check the ionisation current on start-up and on each service call.

The reason for a low ionisation current may be leaking currents, bad connection to earth, dirt or a faulty position of the flame electrode in the burner head. Sometimes also a faulty gas/air mixture may cause too weak a ionisation current.

The ionisation current is measured by means of a microampere meter (μA) connected in series with the flame electrode and the gas burner control.

Connect the μA -meter, see figure. Min. required ionisation current according to table. In practice this current must be considerably higher, preferably more than $10 \mu\text{A}$. All the gas burners are equipped with a ionisation cable that can be slit which facilitates the connection of the μA -device.

Gas pressure switches:

Adjustment range:

2,5-50 mbar GW 50

5-150 mbar GW 150

Adjustment of min. gas pressure switch

The min. pressure switch should react if the gas pressure is too low and prevent the burner from starting. Too low a gas pressure during operation should stop the burner. The burner may start again when the rated pressure has been reached.

Remove the protective cover. Connect a pressure gauge for measuring the rated pressure. Decide on pressure at which the gas switch should switch off. Set this pressure by means of the valve. Carefully turn the knob (see figure) until the gas pressure switch switches off. The value shown on the scale should then approximately correspond with the value shown on the pressure gauge. Tolerance on scale appr. $\pm 15 \%$. Open the ball valve.

Adjustment of max. gas pressure switch

The burner is equipped with a max. gas pressure switch only on request. It should stop the burner if the gas pressure exceeds the set value. The burner can then only be re-started manually (gas burner control or overpressure switch).

Remove the protective cover. Connect a pressure gauge for measuring the rated gas pressure. Decide on pressure at which the gas pressure switch should switch off. Turn the adjustment knob to this value. Tolerance on the scale $\pm 15\%$.

Adjustment of air pressure switch

The air pressure switch should stop the burner if the air volume is reduced.

The air proving device shall be adjusted in such a way that if there is insufficient air supply at the highest or lowest burner operating stage, the device operates before the supervised pressure is less than 80% of the pressure at the controlled stage and the CO content of the combustion products exceeds 1% by volume.

Air pressure switch:

Adjustment range ca:

1-10 mbar LGW 10

2,5-50 mbar LGW 50

Gas control	Connection to terminal in gas control	Min. ionisation current required
LME	1	$5 \mu\text{A}$
LGB	1	$10 \mu\text{A}$
LFL	24	$10 \mu\text{A}$
MMI 810	2	$5 \mu\text{A}$
TMG 740-3	1	$5 \mu\text{A}$

Flame monitoring

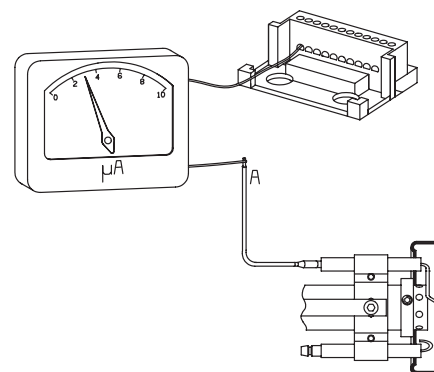

Gas pressure switch, air pressure switch

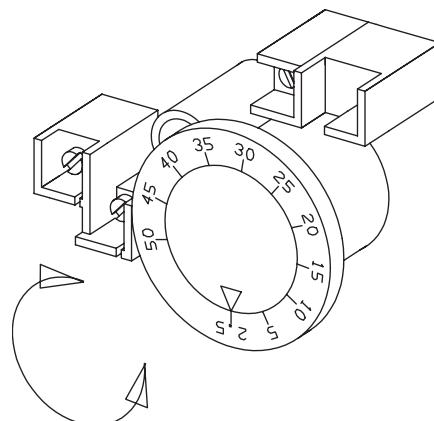

FINAL TEST OF THE INSTALLATION

- Make repeated start attempts to ensure that the adjustments function.
- Close the ball valve during operation to check that the gas switch switches off at the set value.
- Remove the hose for the air pressure switch to check that the burner locks out.
- Check that all protective covers and measurement nipples are mounted and fastened.
- Fill out necessary test reports.
- Instruct the persons in charge of the operation on the service and maintenance of the installation and what to do should any troubles occur.
- Inspection and service must only be carried out by authorized people.

Fault location, functional troubles

Trouble free operation is dependent on three factors: electricity, gas and air supply. Should there be any changes in the ratio between these three factors there is a risk of break downs. It has been proved that most break downs are caused by simple faults. Before calling the service engineer, the following should therefore be checked:

- Is the gas cock open?
- Are all fuses in order and the current switched on?
- Are the thermostats correctly set?
- Are pressostats, overheating protection etc. in operating position and not locked-out?
- Is the gas pressure sufficient?
- Is the gas burner control in start position?
- Has the gas control or the motor protector locked out? - Reset.
- Is the circulation pump in operation?
- Is there a supply of fresh air to the installation?

If integral components are of a different make from what is stated in this manual, see the enclosed loose-leaf.

FAULT LOCATION GUIDE

Gas burner

The basis for trouble free operation can only be ensured by the correct combined effect of the three factors: electricity, gas flow and combustion air. Should any of these factors change troubles may arise.

To facilitate fault location we have drawn up a scheme showing the most frequent faults in a gas burner installation and the remedies.

It has been proved that many troubles have rather simple causes. Before calling the serviceman the following checks should be made:

1. Are the gas cocks of the installation open?
2. Are the fuses in order and the current switched on?
3. Are the controls (room thermostat, boiler thermostat etc.) correctly adjusted?
4. Is the gas pressure to the burner sufficient?
5. Is the gas relay of the burner ready for start and not locked out?
6. Is the air supply to the burner sufficient?

CAUSE	REMEDY
The burner does not start	
No gas	Check that all gas cocks are open.
No voltage	Check fuses, thermostats and electrical connections
The burner motor fails to start	The thermal protection has locked out. Motor defective.
The gas relay is defective	Replace
Burner motor is running but no ignition after the prepurge time has elapsed	
No voltage on the terminals	Check the contact. Replace faulty relay
The ignition electrodes in contact with each other or with earth	Adjust
The porcelain of the electrodes is broken	Replace the electrodes

CAUSE

REMEDY

The cable shoes have bad contact

Improve the contact

The ignition cables are damaged

Replace

The ignition transformer is damaged, no voltage on the secondary side

Replace the transformer

The ignition cable and the ionisation cable have been transposed.

Change

No flame establishment in spite of a trouble free start

The gas solenoid valve defective

Replace

The gas solenoid valve does not open in spite of its obtaining voltage

Replace coil or the whole valve if necessary.

No voltage to the solenoid valve

Check the contact

No electrical connection through the air pressure switch

Test the adjustment and the function of the air pressure switch

The starting load is not correctly adjusted

Reduce or increase the gas supply, reduce the quantity of air

Gas relay defective

Replace

Air pressure switch incorrectly adjusted or defective

Check the adjustment and readjust.

No response as the cams of the servomotor are not correctly adjusted or out of position.

The burner locks out after the safety time has elapsed in spite of flame establishment

No ionisation current or the UV-cell in wrong position

Adjust the ionisation electrode and the UV-cell, examine cables and connections.

The supervision part of the gas relay is defective

Replace the relay

CAUSE

REMEDY

Voltage lower than 185 V

Contact the electricity authorities.

The ignition electrodes are disturbing the ionisation current

Adjust the ignition electrodes, repole the ignition transformer if necessary.

Bad earthing

Arrange for proper earthing.

Phase and neutral transposed

See wiring diagram and change.

The burner locks out during pre-purge

Air pressure switch defective or incorrectly adjusted

The starting load is not correctly adjusted

Reduce or increase the gas supply. Reduce the quantity of air.

The gas pressure is too low

Increase the pressure. Contact the gas supply company if necessary.

Pulsations at start

The ignition electrodes are wrongly adjusted

Readjust.

The gas pressure is too high

Check and adjust by means of a pressure gauge and a pressure adjustment valve.

The flue gas side is blocked

Check the chimney flue.

Pulsations during operation

The burner is not correctly adjusted

Readjust

The burner is dirty

Clean the burner.

Defective chimney

Check and change the dimensions if necessary.

The burner is operating correctly but locking out now and then

The ionisation current is too low

Check. Must be at least 4 μ A according to the relay manufacturer but should be 8-20 μ A.

The UV-cell is in a wrong position

Adjust.

Voltage drop at certain times

Must not drop more than 15% of the rated current. Contact the electricity authorities if necessary.

Air pressure switch defective or incorrectly adjusted

Spark-over in ignition electrodes

Replace the electrodes

CAUSE

REMEDY

The ambient temperature of the gas relay is too high

Heat insulate, max. 60° C.

The ignition spark is too weak

Check the transformer

Bad combustion

Bad draught conditions

Check the chimney

The flue gas temperature is too high

The boiler is overloaded. Reduce the quantity of gas.

The CO₂-content is too low

Check the boiler with regard to leaks. Choke the draught if it is too high.

The CO-content is too high

Excess air when using natural gas and gasoil (propane, butane)

Choke the air.

Air shortage

Open the air supply. Check the flue gas damper.

The holes in the gas nozzle are clogged

Clean.

The fresh air intake is too small

Check and enlarge.

The flame is not burning straight because the burner head is out of position

Check the burner head and readjust.

Condensation in boiler and chimney

The flow gas temperature is too low or the quantity of gas is not sufficient

Increase the flue gas temperature by increasing the gas supply. Insulate the chimney

Declaration of conformity



Gas burner

Zertifikat TÜV Süddeutschland

Certificate No	Burner	Certificate No	Burner
CE-0085 BT 0064	BFG1	CE-0085 BP 0352	BG550
CE-0085 AO 0230	BG100	CE-0085 BP 0353	BG550LN
CE-0085 AP 0623	BG150	CE-0085 AO 0084	BG600LN
CE-0085 AP 0624	BG200	CE-0085 BP 0354	BG650
CE-0085 AT 0192	STG120, STG146	CE-0085 AT 0313	BG700
CE-0085 AP 0625	BG300	CE-0085 AT 0314	BG800
CE-0085 AP 0626	BG400	CE-0085 BR 5754	BG950
CE-0085 AU 0156	BG450		

Enertech AB declares that the above-mentioned products comply with the following standards or other normative documents and meet applicable sections of the EU directive.

Enertech AB försäkrar under eget ansvar att ovanstående produkter är i överensstämmelse med följande standarder eller andra regelgivande dokument och uppfyller tillämpliga delar i EU direktiv.

Enertech AB erklärt hiemit, dass oben genannten Produkte mit den folgenden Normen oder anderen normativen Dokumenten übereinstimmen und die anwendbaren Teile der EU-Richtlinie erfüllen.

Enertech AB déclare que les produits ci-dessus mentionnés sont conformes aux normes ou autres documents normatifs suivants, et répondent aux sections applicables de la directive EU.

Document:	EN 676	
	DIN EN 60335-2-102	
EU Directive	90 / 396 / EEC	Gas Directive
	2004 / 108 / EC	EMC Directive
	2006 / 95 / EC	Low voltage Directive

By conforming to the above-mentioned standards and directives, the burner will receive the CE marking.

Genom att brännaren uppfyller ovanstående standarder och direktiv erhåller brännaren CE - märkningen.

Durch Übereinstimmung mit den oben genannten Normen und Richtlinien erhält der Brenner die CE-Kennzeichnung.

De par sa conformité aux normes et directives mentionnées ci-dessus, le brûleur recevra le marquage CE de conformité.

Enertech AB Bentone Division is quality certified according to SS-EN ISO 9001

Enertech AB Bentone Division är kvalitetscertifierat enligt SS-EN ISO 9001

Enertech AB Bentone Division ist nach SS-EN ISO 9001 qualitätszertifiziert.

Enertech AB Bentone Division a reçu la certification d'assurance qualité SS-EN ISO 9001 qualitätszertifiziert.

Ljungby, Sweden, 141127 (27/11/14)

ENERTECH AB Bentone Division

Box 309

SE-341 26 Ljungby Sweden

Håkan Lennartsson

 **Bentone**[®]
Enertech Group

