



Providing sustainable energy solutions worldwide

Installation- and maintenance instruction
B10FUV

DESCRIPTION

Components

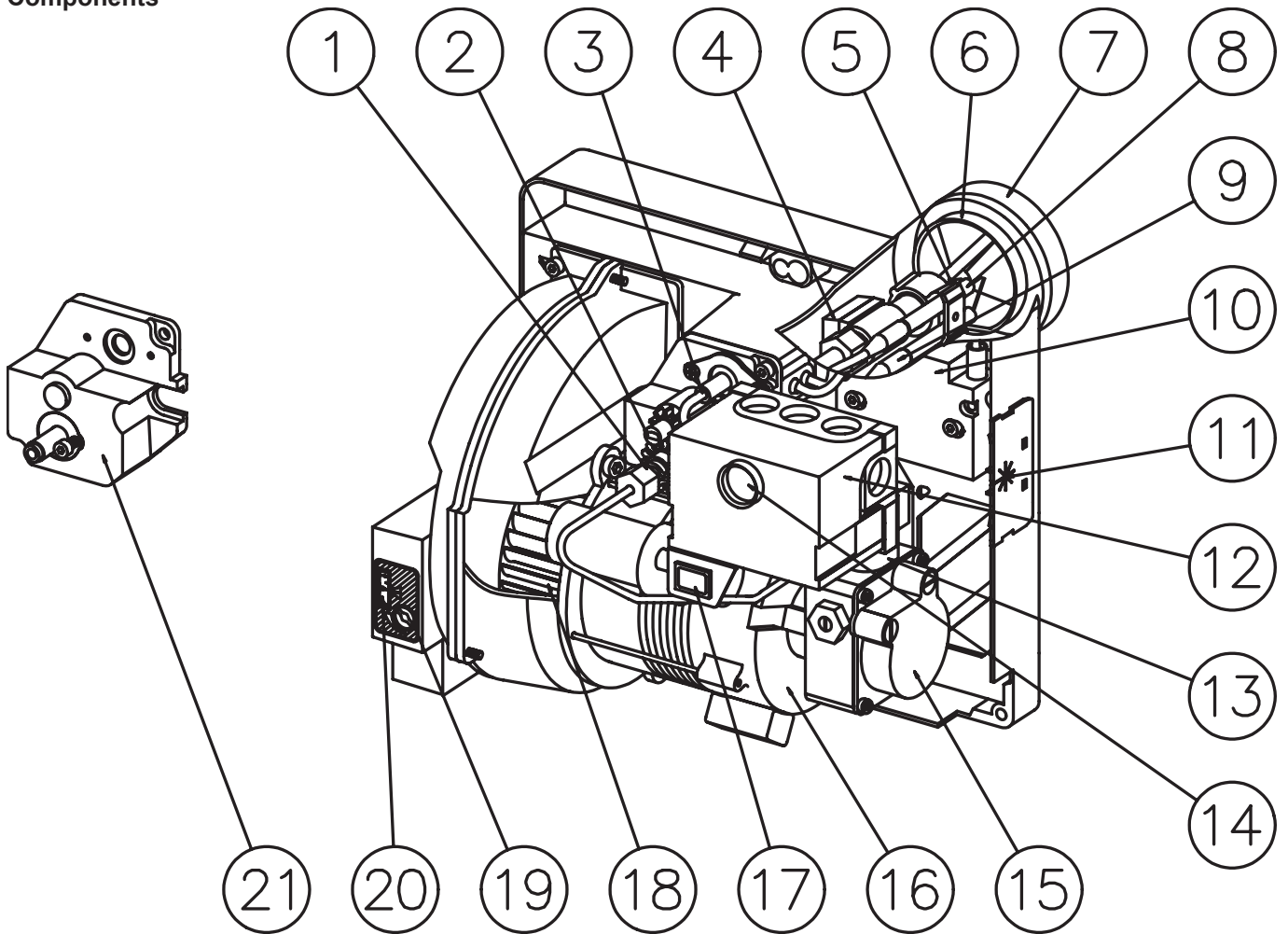

- 1. Scale, nozzle assembly
- 2. Nozzle assembly adjustment
- 3. Photocell
- 4. Preheater
- 5. Nozzle
- 6. Schrouded disc
- 7. Blast tube
- 8. Ignition electrodes

- 9. Ignition cables
- 10. Ignition transformer
- 11. Electrical connection
- 12. Control box
- 13. Solenoid valve
- 14. Reset button
- 15. Pump
- 16. Motor

- 17. Indicating lamp, preheater
- 18. Fan wheel
- 19. Air regulation
- 20. Scale, air regulation
- 21. Cover, nozzle assembly
(fixed burner head)

Dimensions

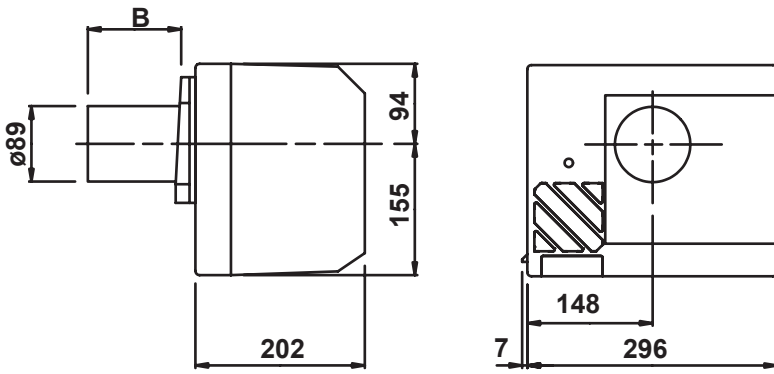

Flange A

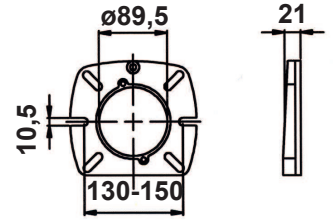

Flange B

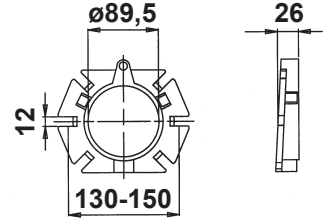

Flange C

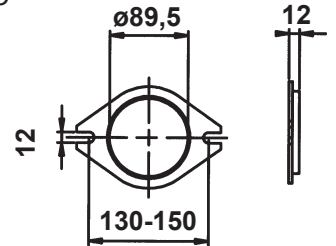

Burner tube	Length of burner tube	Flange A Measure B	Flange B Measure B	Flange C Measure B
FUV	56	31	26	40
FUV	103	78	73	87
FUV	133	108	103	117
FUV	194	169	164	178

Output range and nozzles recommended

Burner tube	Oil capacity		Capacity		Recommended Nozzle		Recommended Pump pressure
	kg/h	kW	Mcal/h	Angle	Size	Type	Bar
FUV	1,2-3,2	14-38	12-33	80°	0,50-0,60	H	10
				60°	0,65-0,85	S or R	10

The net calorific value of 11,86 kWh/kg for light oil has been used.

Recommended nozzle

Because of different boiler types existing on the market, with varying combustion chamber designs, it is

not possible to state a definite spray angle or spray pattern.

Note that the spray angle and the spray pattern change with the pump pressure.

Electrode adjustment

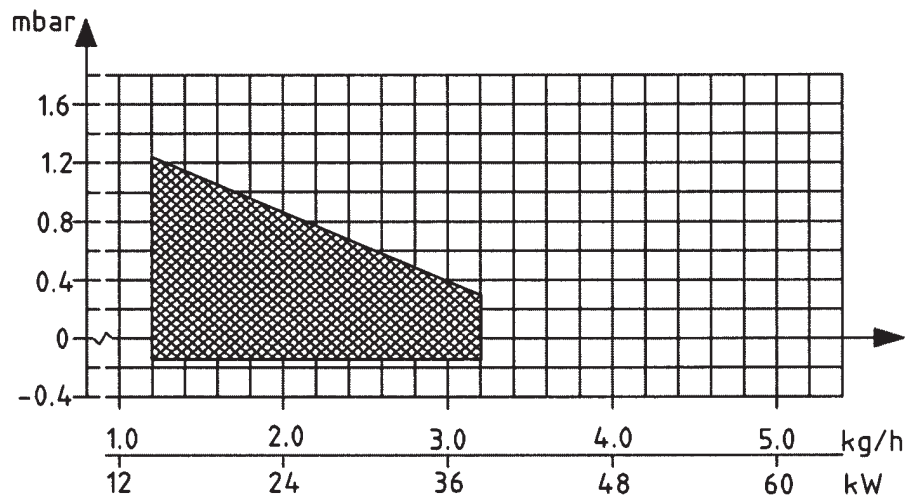
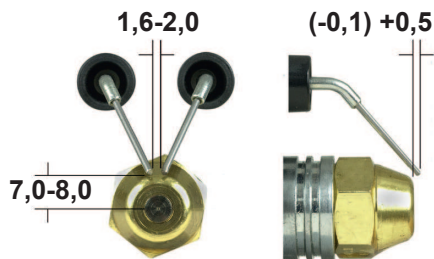

GENERAL INSTRUCTIONS

General rules

The installation of an oil burner should be carried out in accordance with local regulations. The installer of the burner must therefore be aware of all regulations relating to oil and combustion.

Only oil suitable for the burner should be used and then in combination with a suitable oil filter before the oil pump of the burner.

If the burner is replacing an existing burner make sure that the oil filter is replaced or cleaned. The installation must only be undertaken by experienced personnel. Care should be taken by the installer to ensure that no electrical cables or fuel/gas pipes are trapped or damaged during installation or service/maintenance.

Installation instructions

General installation instructions accompany the burner and should be left in a prominent place adjacent to the burner.

Adjustment of burner

The burner is from the factory pre-set to an average value that must then be adjusted to the boiler in question.

All burner adjustments must be made in accordance with boiler manufacturers instructions. These must include the checking of flue gas temperatures, average water temperature and CO₂ or O₂ concentration.

To adjust the combustion device, start by increasing the air volume and the nozzle assembly somewhat. When the burner starts it is burning with excess air and smoke number 0. Reduce the nozzle assembly

adjustment until soot occurs, and then increase the adjustment to make the soot disappear again. Then the volume of air is reduced until soot occurs and increased again to reach a combustion free of soot.

By this procedure an optimum adjustment is obtained. If larger nozzles are used the preadjustment of both the air volume and the nozzle assembly must be increased.

A whistling sound may be heard which can be eliminated or reduced as follows: Increase the nozzle assembly adjustment somewhat. The CO₂-content and consequently the air volume will then be reduced.

Condensation in chimney

A modern burner works with less excess air and often also with smaller nozzles than older models.

This increases the efficiency but also the risk of condensation in the chimney.

The risk increases if the area of the chimney flue is too large. The temperature of the flue gases should exceed 60°C measured 0,5 metres from the chimney top.

Measures to raise the temperature:

Insulate the chimney in cold attics

Install a tube in the chimney

Install a draught regulator (dilutes the flue gases during operation and dries them up during standstill)

Increase the oil quantity

Raise the flue gas temperature by removing turbulators, if any, in the boiler.

Instructions for use

The end user of the burner should be instructed about the operation and safety features of the burner.

He should also be made aware of the importance of the area around the boiler/burner being kept free of combustible material.

Pump adjustment

See separate description.

Adjustment of burner

To obtain a correct adjustment a flue gas analysis and a temperature measurement must be carried out. Otherwise there is a risk that a bad adjustment may cause a formation of soot, bad efficiency or condensate in the chimney.

Air adjustment

On all burners the air adjustment can be made with or without the cover fitted. Final fine adjustment must be made with the cover on.

Maintenance

The boiler/burner should be examined regularly for any signs of malfunction or oil leakage.

Fastening of the burner to the boiler (flange)

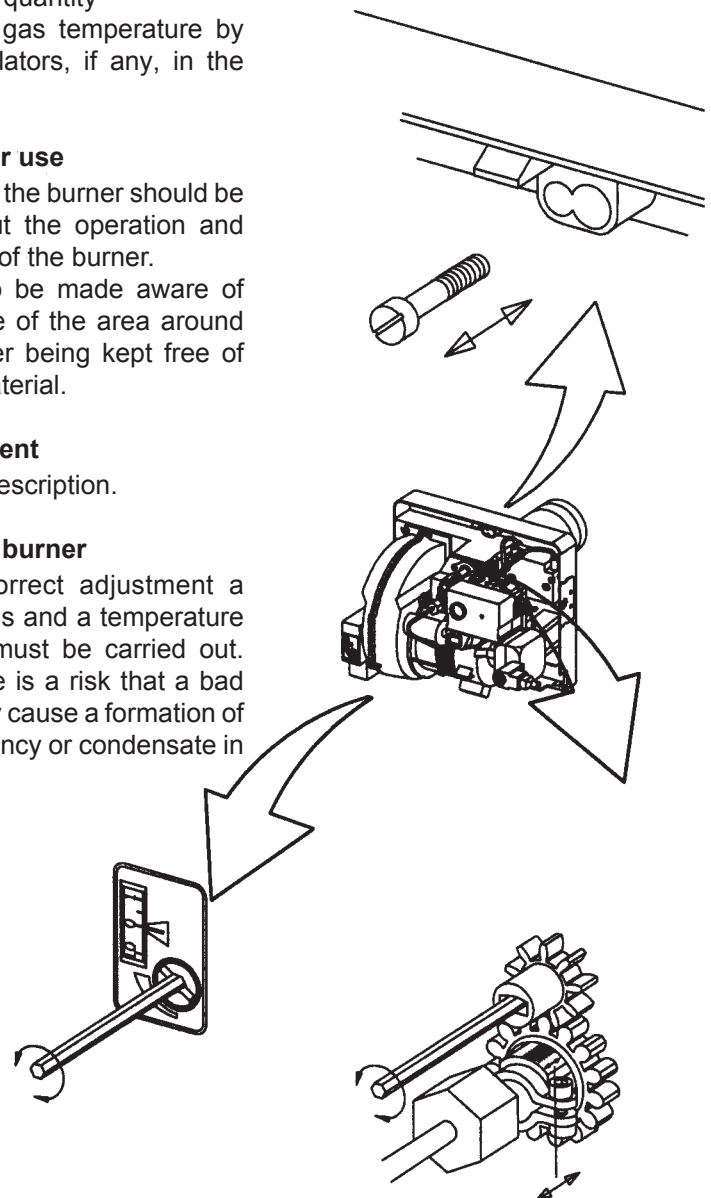

Air adjustment

Adjustment of nozzle assembly

MAINTENANCE OF OIL BURNER

Warning: Before doing any service switch off power at the main switch and cut off the oil supply.

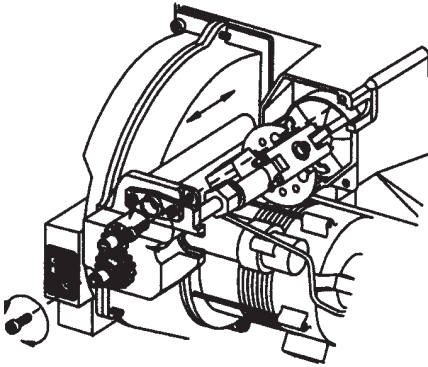

Service of burner head

(alt. a)

1. Remove the cover.
2. Withdraw the photo resistor.
3. Loosen the connecting pipe.
4. Loosen two fixing screws of the nozzle assembly cover.
5. Retract the nozzle assembly so far that the ignition cables can be removed from the ignition electrodes.
6. Remove the nozzle assembly.

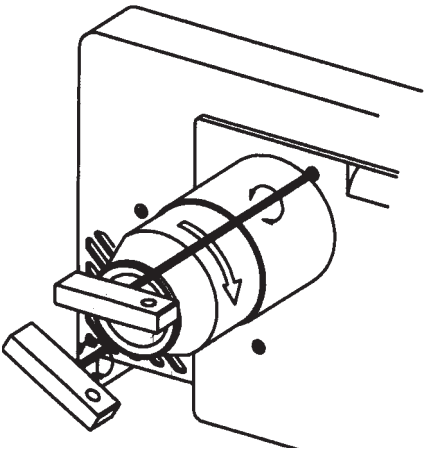

Service of burner head

(alt. B)

1. Slacken retaining screws.
2. Remove the burner.
3. Loosen the two blast tube retaining screws.
4. Turn the tube to the right and remove.

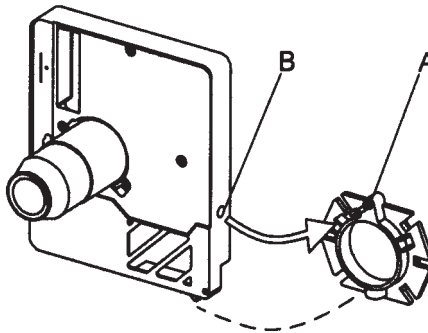

Suspension of burner

- A. Pin for suspension of burner.
- B. Hole for suspension (also available on the right side).

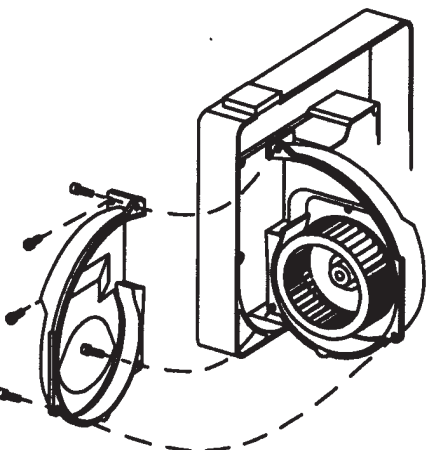

Cleaning of fan wheel

- Loosen five fixing screws.
- Remove the fan housing half.

ELECTRIC EQUIPMENT

Oil burner control: LMO14.113... / LMO24.255...

List of components

- A1 Oil burner control
- A2 Twin thermostat
- E1 Preheater
- F1 Fuse, max. 10A
- H1 Alarm lamp
- H2 Signal lamp (optional)
- M1 Burner motor
- P1 Time meter (optional)
- R1 Photoresistor
- S3 Main switch
- T1 Ignition transformer
- Y1 Solenoid valve
- X1 Plug-in contact, burner
- X2 Plug-in contact, boiler

The colours of the preheater cable:

- A Blue
- B Brown
- C Black

Outer electrical connection

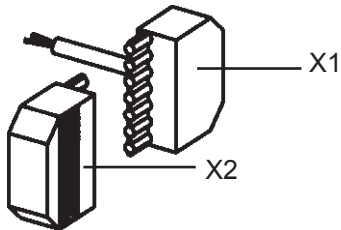

Mains connection and fuses in accordance with local regulations.

* If there is no plug-in contact (X2) on the boiler, connect to the contact enclosed. In case the twin thermostat is in series on incoming phase L1, a loop between the terminals T1 and T2 is necessary.

Wiring diagram

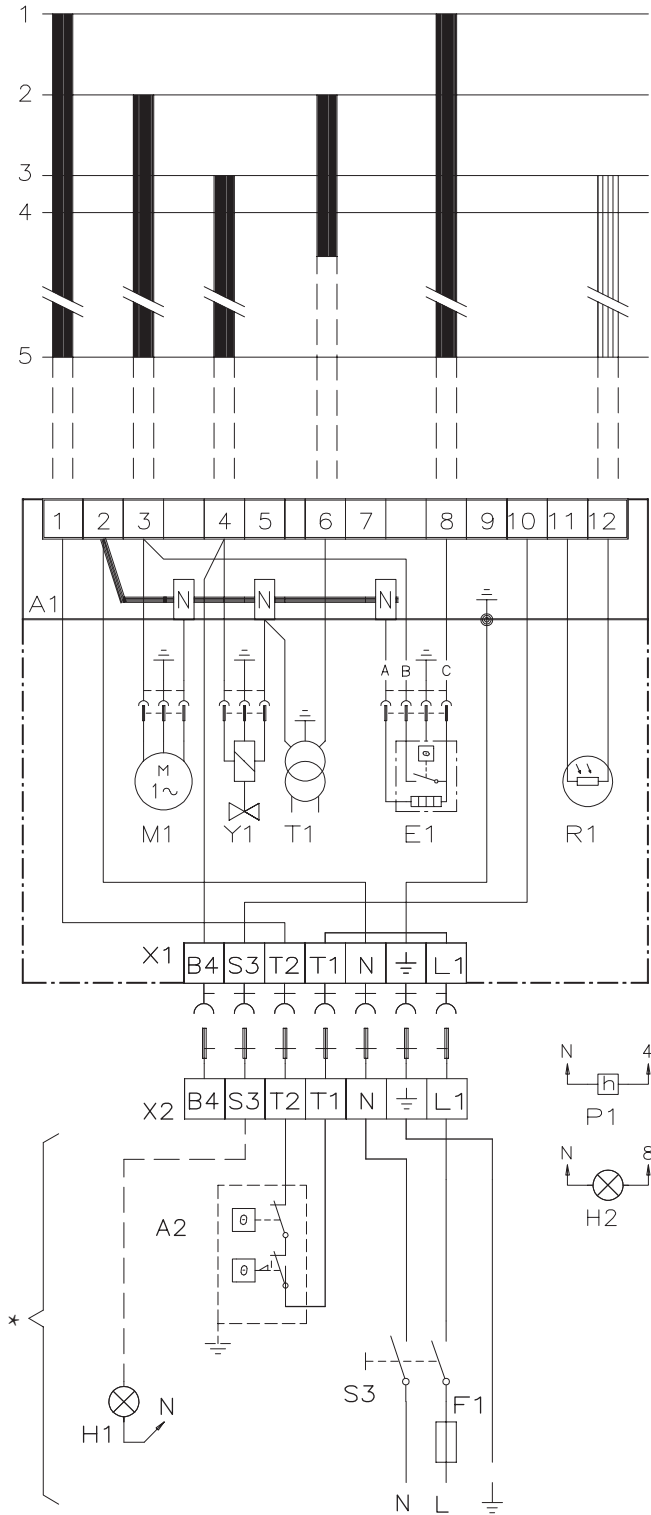

ELECTRIC EQUIPMENT

Function

1. Switch on operating switch and twin thermostat

The burner motor starts, an ignition spark is formed, the prepurge goes on till the prepurge period expires and the solenoid valve opens (2).

2. Solenoid valve opens

Oil mist is formed and ignited. The photocell indicates a flame. The ignition spark goes out after flame indication (See Technical data oil burner control).

3. The safety time expires

- a. If no flame is established before this time limit the control cuts out.
- b. If for some reasons the flame disappears after this time limit, the burner will make an attempt to re-start.

3-4. Operating position

If the burner operation is interrupted by means of the main switch or the thermostat, a new start takes place when the conditions in accordance with point 1 are fulfilled.

The oil burner control cuts out

A red lamp in the control is lit. Press the reset button and the burner re-starts.

Technical data oil burner control

	LMO14.113...	LMO24.255...
Pre-ignition time:	15 s	25 s
Pre-purge time:	16 s	26 s
Post-ignition time:	3 s	5 s
Safety lock-out time:	< 10 s	< 5 s
Reset time after lockout:	< 1 s	< 1 s
Reaction time on flame failure:	< 1 s	< 1 s
Ambient temperature:	-5 +60°C	-20 - +60°C
Min. current with flame established:	45 µA	45 µA
Max. photo current at start:	5,5 µA	5,5 µA

Control of photo current

Current through photo unit is measured with a d.c. ammeter (a moving coil instrument connected in series with the photo unit).

Colour codes LMO14/24

When the burner starts, three signal lights in the reset switch indicate the normal sequence, as well as provide indication if something abnormal is happening in accordance with the following table:

Preheater in operation	Solid yellow
Ignition switched on	Flashing yellow
Normal operation	Solid green
Operation, poor flame signal	Flashing green
Undervoltage	Flashing yellow-red
Fault, alarm	Solid red
False light	Flashing red-green
Communication mode	Fluttering red

Fault codes LMO14/24

When the red light for a blocked relay box comes on, you can get information about what has caused the problem by pressing and holding the reset button for 3 seconds.

The number of flashes below is repeated with a pause in between.

2 flashes	No flame signal when safety time expires
4 flashes	False light during start
7 flashes	3 x Losses of flame during operation
8 flashes	Time-out for preheater *
10 flashes	Incorrect wiring, internal fault or simultaneous occurrence of two faults

* In order for this fault code to occur, the preheater shall not reach its cut-off temperature within 10 mins. from switch on.

To return to normal operation: Press the reset button for 1 second. If the reset button is instead kept pressed a second time for at least 3 seconds, you can, via an interface, obtain the corresponding information on a computer or flue gas analyser.

To return to normal operation: Press the reset button for 1 second

INSTRUCTIONS PUMP TYPE DANFOSS BFP41

Technical data

Viscosity range: 1,3-12,0 mm²/s
 Pressure range: 7-15 bar
 Oil temperature: -10 to +70°C

Components

1. Nozzle port G1/8"
2. Pressure gauge port
3. Pressure adjustment, 4mm allen key
4. Cartridge filter
5. Vacuum gauge port G1/8"
6. Return line G1/4"
7. Suction line G1/4"
8. Return plug

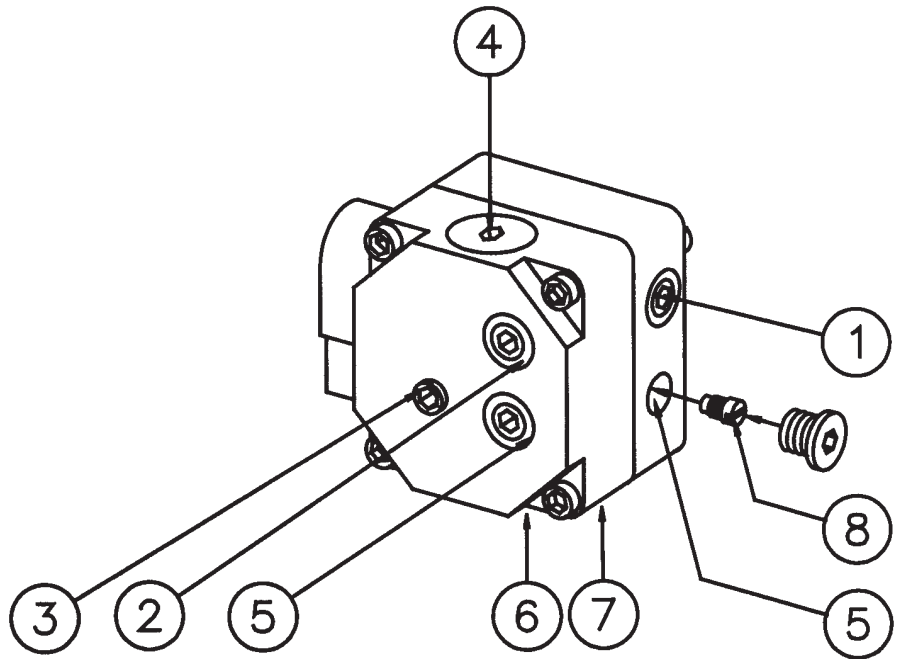

Suction line tables

The suction line tables consist of theoretically calculated values where the pipe dimensions and oil velocity have been matched so that turbulences will not occur. Such turbulences will result in increased pressure losses and in acoustic noise in the pipe system. In addition to drawn copper piping a pipe system usually comprises 4 elbows, a non-return valve, a cut-off valve and an external oil filter.

The sum of these individual resistances is so insignificant that they can be disregarded. The tables do not include any lengths exceeding 100 m as experience shows that longer lengths are not needed.

The tables apply to a standard fuel oil of normal commercial quality according to current standards. On commissioning with an empty tube system the oil pump should not be run without oil for more than 5 min. (a condition is that the pump is being lubricated during operation).

The tables state the total suction line length in metres at a nozzle capacity of 2,5 kg/h. Max. permissible pressure at the suction and pressure side is 2,0 bar.

Purging

On 1-pipe systems it is necessary to purge the pump. On 2-pipe systems purging is automatic through the return line.

1-pipe system Height H Pipe diameter		1-pipe system Height H Pipe diameter																																																																																																
m	<table border="1"> <thead> <tr> <th>ø4 mm</th> <th>ø5 mm</th> <th>ø6 mm</th> </tr> </thead> <tbody> <tr><td>4,0</td><td>51</td><td>100</td></tr> <tr><td>3,5</td><td>45</td><td>100</td></tr> <tr><td>3,0</td><td>38</td><td>94</td></tr> <tr><td>2,5</td><td>32</td><td>78</td></tr> <tr><td>2,0</td><td>26</td><td>62</td></tr> <tr><td>1,5</td><td>19</td><td>47</td></tr> <tr><td>1,0</td><td>13</td><td>31</td></tr> <tr><td>0,5</td><td>6</td><td>16</td></tr> </tbody> </table>	ø4 mm	ø5 mm	ø6 mm	4,0	51	100	3,5	45	100	3,0	38	94	2,5	32	78	2,0	26	62	1,5	19	47	1,0	13	31	0,5	6	16	<table border="1"> <thead> <tr> <th>ø4 mm</th> <th>ø5 mm</th> <th>ø6 mm</th> </tr> </thead> <tbody> <tr><td>m</td><td>m</td><td>m</td></tr> <tr><td>m</td><td>m</td><td>m</td></tr> <tr><td>m</td><td>m</td><td>m</td></tr> <tr><td>m</td><td>m</td><td>m</td></tr> <tr><td>m</td><td>m</td><td>m</td></tr> <tr><td>m</td><td>m</td><td>m</td></tr> <tr><td>m</td><td>m</td><td>m</td></tr> <tr><td>m</td><td>m</td><td>m</td></tr> <tr><td>m</td><td>m</td><td>m</td></tr> <tr><td>m</td><td>m</td><td>m</td></tr> </tbody> </table>	ø4 mm	ø5 mm	ø6 mm	m	m	m	m	m	m	m	m	m	m	m	m	m	m	m	m	m	m	m	m	m	m	m	m	m	m	m	m	m	m																																				
ø4 mm	ø5 mm	ø6 mm																																																																																																
4,0	51	100																																																																																																
3,5	45	100																																																																																																
3,0	38	94																																																																																																
2,5	32	78																																																																																																
2,0	26	62																																																																																																
1,5	19	47																																																																																																
1,0	13	31																																																																																																
0,5	6	16																																																																																																
ø4 mm	ø5 mm	ø6 mm																																																																																																
m	m	m																																																																																																
m	m	m																																																																																																
m	m	m																																																																																																
m	m	m																																																																																																
m	m	m																																																																																																
m	m	m																																																																																																
m	m	m																																																																																																
m	m	m																																																																																																
m	m	m																																																																																																
m	m	m																																																																																																
Two-pipe system Height H Pipe diameter		Two-pipe system Height H Pipe diameter																																																																																																
m	<table border="1"> <thead> <tr> <th>ø6 mm</th> <th>ø8 mm</th> <th>ø10 mm</th> </tr> </thead> <tbody> <tr><td>4,0</td><td>33</td><td>100</td></tr> <tr><td>3,5</td><td>31</td><td>98</td></tr> <tr><td>3,0</td><td>29</td><td>91</td></tr> <tr><td>2,5</td><td>27</td><td>85</td></tr> <tr><td>2,0</td><td>25</td><td>79</td></tr> <tr><td>1,5</td><td>23</td><td>72</td></tr> <tr><td>1,0</td><td>21</td><td>66</td></tr> <tr><td>0,5</td><td>19</td><td>60</td></tr> </tbody> </table>	ø6 mm	ø8 mm	ø10 mm	4,0	33	100	3,5	31	98	3,0	29	91	2,5	27	85	2,0	25	79	1,5	23	72	1,0	21	66	0,5	19	60	<table border="1"> <thead> <tr> <th>ø6 mm</th> <th>ø8 mm</th> <th>ø10 mm</th> </tr> </thead> <tbody> <tr><td>m</td><td>m</td><td>m</td></tr> <tr><td>m</td><td>m</td><td>m</td></tr> <tr><td>m</td><td>m</td><td>m</td></tr> <tr><td>m</td><td>m</td><td>m</td></tr> <tr><td>m</td><td>m</td><td>m</td></tr> <tr><td>m</td><td>m</td><td>m</td></tr> <tr><td>m</td><td>m</td><td>m</td></tr> <tr><td>m</td><td>m</td><td>m</td></tr> <tr><td>m</td><td>m</td><td>m</td></tr> <tr><td>m</td><td>m</td><td>m</td></tr> <tr><td>m</td><td>m</td><td>m</td></tr> <tr><td>m</td><td>m</td><td>m</td></tr> <tr><td>m</td><td>m</td><td>m</td></tr> <tr><td>m</td><td>m</td><td>m</td></tr> <tr><td>m</td><td>m</td><td>m</td></tr> <tr><td>m</td><td>m</td><td>m</td></tr> <tr><td>m</td><td>m</td><td>m</td></tr> <tr><td>m</td><td>m</td><td>m</td></tr> <tr><td>m</td><td>m</td><td>m</td></tr> <tr><td>m</td><td>m</td><td>m</td></tr> <tr><td>m</td><td>m</td><td>m</td></tr> <tr><td>m</td><td>m</td><td>m</td></tr> </tbody> </table>	ø6 mm	ø8 mm	ø10 mm	m	m	m	m	m	m	m	m	m	m	m	m	m	m	m	m	m	m	m	m	m	m	m	m	m	m	m	m	m	m	m	m	m	m	m	m	m	m	m	m	m	m	m	m	m	m	m	m	m	m	m	m	m	m	m	m	m	m	m	m	m	m	m	m	m	m
ø6 mm	ø8 mm	ø10 mm																																																																																																
4,0	33	100																																																																																																
3,5	31	98																																																																																																
3,0	29	91																																																																																																
2,5	27	85																																																																																																
2,0	25	79																																																																																																
1,5	23	72																																																																																																
1,0	21	66																																																																																																
0,5	19	60																																																																																																
ø6 mm	ø8 mm	ø10 mm																																																																																																
m	m	m																																																																																																
m	m	m																																																																																																
m	m	m																																																																																																
m	m	m																																																																																																
m	m	m																																																																																																
m	m	m																																																																																																
m	m	m																																																																																																
m	m	m																																																																																																
m	m	m																																																																																																
m	m	m																																																																																																
m	m	m																																																																																																
m	m	m																																																																																																
m	m	m																																																																																																
m	m	m																																																																																																
m	m	m																																																																																																
m	m	m																																																																																																
m	m	m																																																																																																
m	m	m																																																																																																
m	m	m																																																																																																
m	m	m																																																																																																
m	m	m																																																																																																
m	m	m																																																																																																
		With an underlying tank a 1-pipe-system is not recommended																																																																																																

INSTRUCTIONS PUMP TYPE DANFOSS BFP41

Function Danfoss BFP41

When the oil pump is started, oil is drawn from the suction connection (S) through the filter (H) to the suction side of the gear wheel (C).

The gear wheel then pumps oil to the pressure side and the oil is put under pressure.

The pressure is controlled and kept constant at the set value by the regulating valve (P_1) with the diaphragm (D).

The regulating valve (P_1) distributes the oil quantity supplied by the gear set (C) between the nozzle port (E) and the return side of the pump (R).

The oil quantity utilized is determined by the set pressure on the regulating valve (P_1) and the size of the oil nozzle in the nozzle line.

The valve (P_1) functions in the following way:

- When the opening pressure has been reached, the passage to the return side opens.
- The diaphragm and the spring keep the pump pressure constant at set value.
- If the pump is overloaded, i.e. if you try to get out more

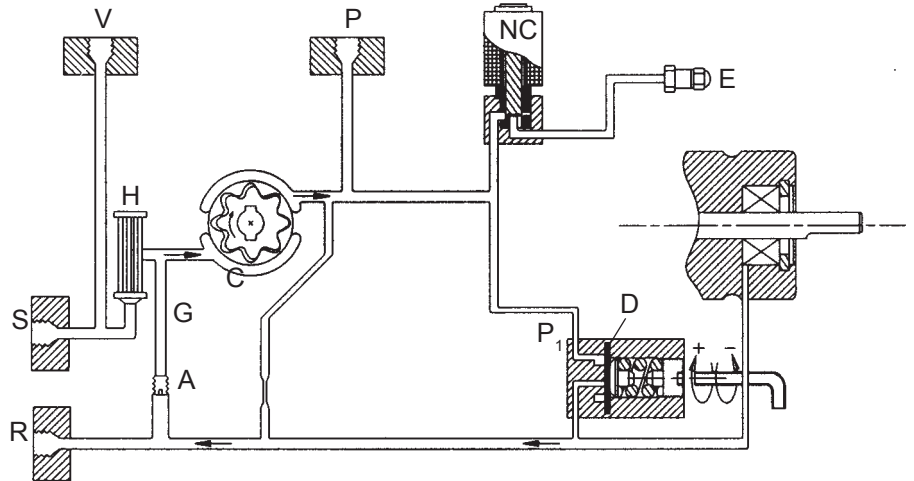

oil than the gear set can supply under existing circumstances, the oil pressure falls below the set value and the valve closes against the return side (R) by means of the diaphragm (D) and goes into starting position.

This can be remedied by:

- Reducing the pump pressure.
- Reducing the oil quantity supplied by using a smaller nozzle.
- Using a pump with a larger capacity.

Burner with preheating

Consider that the oil quantity is reduced at preheating by 5-20% depending on.

- Rise in temperature at the nozzle
- Nozzle design
- Capacity (high capacity - small difference)

Replacement of cartridge filter

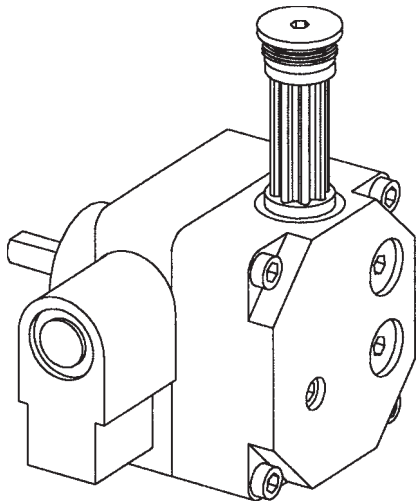

How to remove cartridge filter from plug

Unscrew the cartridge filter plug in the cover by means of a 4 mm allen key and withdraw the cartridge filter. If necessary, put a screwdriver between the cartridge filter and the plug and turn the cartridge filter carefully until it comes off. Reject the cartridge filter and replace it by a new one. Press it on to the plug. Ensure that the O-ring is not damaged. Then fit the new cartridge filter to the pump.

Mounting/dismounting return plug

One pipe system

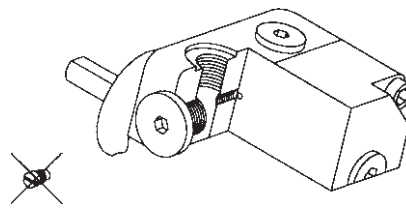

Two pipe system

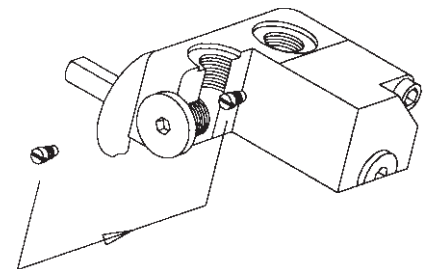

NOZZLE TABLE

Pump pressure bar

Gph	8			9			10			11		
	kg/h	kW	Mcal/h	kg/h	kW	Mcal/h	kg/h	kW	Mcal/h	kg/h	kW	Mcal/h
0,40	1,33	16	13	1,41	17	14	1,49	18	15	1,56	18	16
0,50	1,66	20	17	1,76	21	18	1,86	22	19	1,95	23	20
0,60	2,00	24	20	2,12	25	22	2,23	26	23	2,34	28	24
0,65	2,16	26	22	2,29	27	23	2,42	29	25	2,54	30	26
0,75	2,49	29	25	2,65	31	27	2,79	33	28	2,93	35	30
0,85	2,83	33	29	3,00	36	31	3,16	37	32	3,32	39	34
1,00	3,33	39	34	3,53	42	36	3,72	44	38	3,90	46	40
1,10	3,66	43	37	3,88	46	39	4,09	48	42	4,29	51	44
1,20	3,99	47	41	4,24	50	43	4,47	53	46	4,68	55	48
1,25	4,16	49	42	4,40	52	45	4,65	55	47	4,88	58	50
1,35	4,49	53	46	4,76	56	48	5,02	59	51	5,27	62	54
1,50	4,98	59	51	5,29	63	54	5,58	66	57	5,85	69	60
1,65	5,49	65	56	5,82	69	59	6,14	73	63	6,44	76	66
1,75	5,82	69	59	6,18	73	63	6,51	77	66	6,83	81	70
2,00	6,65	79	68	7,06	84	72	7,45	88	76	7,81	93	80
2,25	7,49	89	76	7,94	94	81	8,38	99	85	8,78	104	89
2,50	8,32	99	85	8,82	105	90	9,31	110	95	9,76	116	99
2,75	9,15	108	93	9,71	115	99	10,24	121	104	10,73	127	109
3,00	9,98	118	102	10,59	126	108	11,16	132	114	11,71	139	119
3,50	11,65	138	119	12,35	146	126	13,03	154	133	13,66	162	139
4,00	13,31	158	136	14,12	167	144	14,89	176	152	15,62	185	159
4,50	14,97	177	153	15,88	188	162	16,75	198	171	17,57	208	179
5,00	16,64	197	170	17,65	209	180	18,62	221	190	19,52	231	199
5,50	18,30	217	187	19,42	230	198	20,48	243	209	21,47	255	219
6,00	19,97	237	204	21,18	251	216	22,34	265	228	23,42	278	239
6,50	21,63	256	220	22,94	272	234	24,20	287	247	25,37	301	259
7,00	23,29	276	237	24,71	293	252	26,06	309	266	27,33	324	279
7,50	24,96	296	254	26,47	314	270	27,92	331	285	29,28	347	298
8,00	26,62	316	271	28,24	335	288	29,79	353	304	31,23	370	318
8,50	28,28	335	288	30,00	356	306	31,65	375	323	33,18	393	338
9,00	29,95	355	305	31,77	377	324	33,59	398	342	35,14	417	358

The table applies to oil with a viscosity of 4,4 mm²/s (cSt) with density 830 kg/m³.

Burner with preheater

Consider that on preheating the oil quantity is reduced by 5-20% depending on.

- Rise in temperature at the nozzle
- Design of nozzle
- Capacity (high capacity - small difference)

NOZZLE TABLE

Pump pressure bar

Gph	12			13			14			15		
	kg/h	kW	Mcal/h	kg/h	kW	Mcal/h	kg/h	kW	Mcal/h	kg/h	kW	Mcal/h
0,40	1,63	19	17	1,70	20	17	1,76	21	18	1,82	21	18
0,50	2,04	24	21	2,12	25	22	2,20	26	22	2,28	27	23
0,60	2,45	29	25	2,55	30	26	2,64	31	27	2,73	32	28
0,65	2,65	31	27	2,75	33	28	2,86	34	29	2,96	35	30
0,75	3,08	36	31	3,18	38	32	3,30	39	34	3,42	40	35
0,85	3,47	41	35	3,61	43	37	3,74	44	38	3,87	46	39
1,00	4,08	48	42	4,24	50	43	4,40	52	45	4,56	54	46
1,10	4,48	53	46	4,67	55	48	4,84	57	49	5,01	59	51
1,20	4,89	58	50	5,09	60	52	5,29	63	54	5,47	65	56
1,25	5,10	60	52	5,30	63	54	5,51	65	56	5,70	68	58
1,35	5,50	65	56	5,73	68	58	5,95	70	61	6,15	73	63
1,50	6,11	72	62	6,36	75	65	6,60	78	67	6,83	81	70
1,65	6,73	80	69	7,00	83	71	7,27	86	74	7,52	89	77
1,75	7,14	85	73	7,42	88	76	7,71	91	79	7,97	94	81
2,00	8,18	97	83	8,49	101	86	8,81	104	90	9,12	108	93
2,25	9,18	109	94	9,55	113	97	9,91	117	101	10,26	122	105
2,50	10,19	121	104	10,61	126	108	11,01	130	112	11,39	135	116
2,75	11,21	133	114	11,67	138	119	12,11	144	123	12,53	148	128
3,00	12,23	145	125	12,73	151	130	13,21	157	135	13,67	162	139
3,50	14,27	169	145	14,85	176	151	15,42	183	157	15,95	189	163
4,00	16,31	193	166	16,97	201	173	17,62	209	180	18,23	216	186
4,50	18,35	217	187	19,10	226	195	19,82	235	202	20,51	243	209
5,00	20,39	242	208	21,22	251	216	22,03	261	225	22,79	270	232
5,50	22,43	266	229	23,34	277	238	24,23	287	247	25,07	297	256
6,00	24,47	290	249	25,46	302	260	26,43	313	269	27,49	326	280
6,50	26,51	314	270	27,58	327	281	28,63	339	292	29,63	351	302
7,00	28,55	338	291	29,70	352	303	30,84	366	314	31,91	378	325
7,50	30,59	363	312	31,83	377	324	33,04	392	337	34,19	405	349
8,00	32,63	387	333	33,95	403	346	35,25	418	359	36,47	432	372
8,50	34,66	411	353	36,07	428	368	37,45	444	382	38,74	459	395
9,00	36,71	435	374	38,19	453	389	39,65	470	404	41,02	486	418

The table applies to oil with a viscosity of 4,4 mm²/s (cSt) with density 830 kg/m³.

Burner with preheater

Consider that on preheating the oil quantity is reduced by 5-20% depending on.

- Rise in temperature at the nozzle
- Design of nozzle
- Capacity (high capacity - small difference)

FAULT LOCATION

Burner fails to start

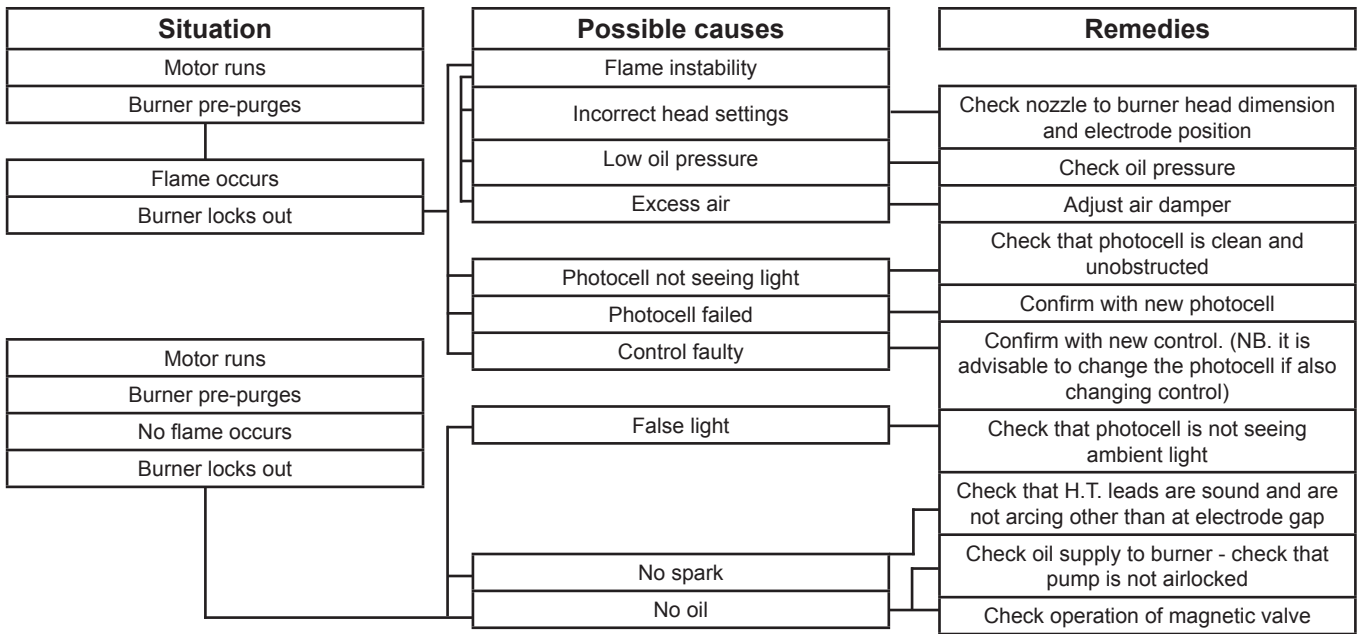

Burner fails to start after normal operation

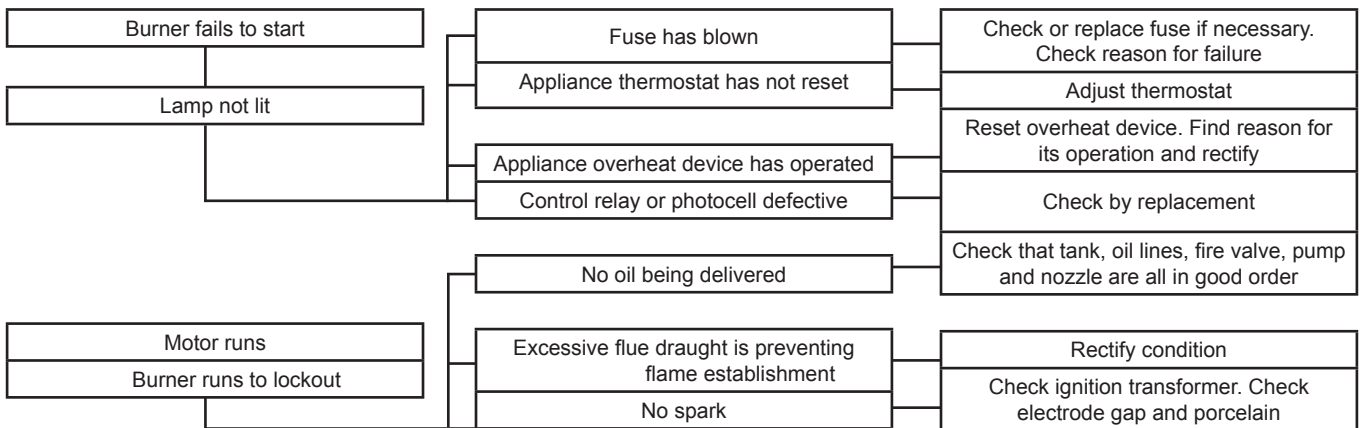

Delayed ignition, burners starts violently

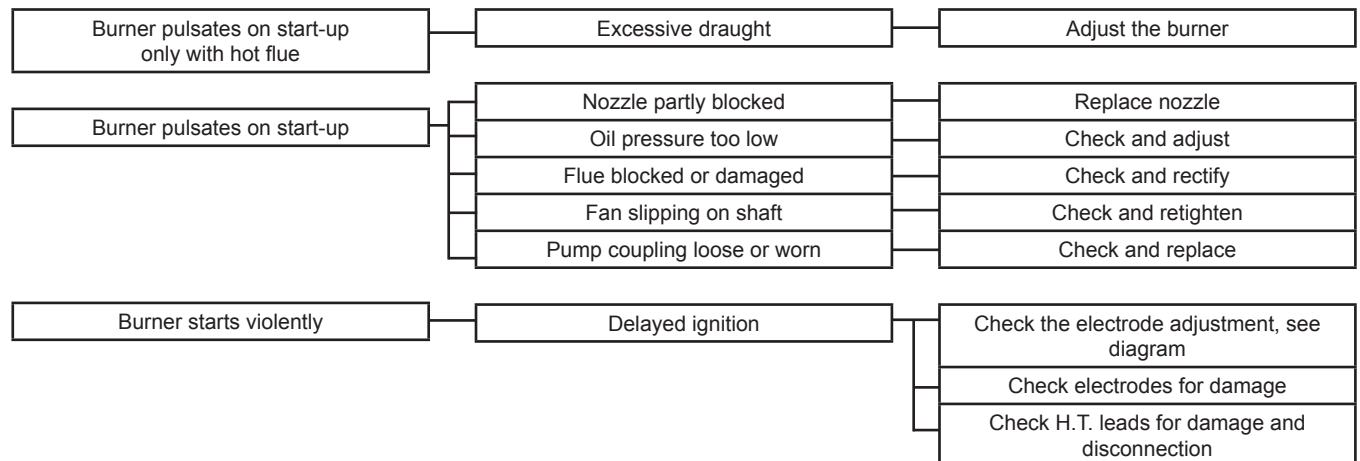

EU Declaration of conformity



Bentone Oilburners

Type

BF 1	ST 133	B 10	B 55
ST 97	ST 146	B 30	B 65
ST 108	B 1	B 40	B 70
ST 120	B 2	B 45	B 80

This declaration of conformity is issued under the sole responsibility of the manufacturer. The object of the declaration described above is in conformity with:

Machinery Directive 2006/42/EC

EMC 2014/30/EU

Restriction of the use of certain hazardous substances (RoHS) Directive 2011/65/EU

References to the relevant harmonised standards used or references to the other technical specifications in relation to which conformity is declared:

EN 267:2009+A 1 :2011 (excluded Annex J/K) Automatic forced draught burners for liquid fuels

Additional information can be downloaded at:

www.bentone.com

Enertech AB
Box 309
S-341 26 LJUNGBY

Ljungby September 26th, 2017

Håkan Lennartsson

Managing Director

Enertech AB

OIL BURNERS MAINTENANCE INSTRUCTIONS

General information

Keep the boiler room clean. Ensure that the boiler room has permanent fresh air intake. Switch off before dismantling the oil burner.

At hinged mounting, make sure that an automatic safety switch is fitted, so that the burner cannot start when the swing door is open.

Don't use the oil fired boiler to burn paper or rubbish, unless the boiler is especially fitted with a hinged door to make this possible.

Don't fill tank while burner is working.

Starting precautions

Make sure that the oil tank is not empty

Make sure that the valves on oil and water supply pipes are open.

Make sure that the boiler flue damper is open.

Make sure that the boiler thermostat is set at the correct temperature.

Switch on the current. Most relay systems have a delayed action so that the burner will not start for perhaps 20 seconds.

With heavy oil the delay will be longer as the burner will not start until the oil in the preheater reaches the required temperature.

If the burner will not start

Press the reset button on the relay. Check that the thermostats are correctly adjusted.

Don't forget the room thermostat, check that any fuses are intact and main switch is on.

If the burner starts but does not ignite

Make an attempt to start the burner.

Never make close repeated start attempts.

Don't restart the burner until the boiler is free from oil gases.

If the burner still does not ignite send for the service engineer.

When switching off during summer

Always use the main switch to cut out the burner even when adjusting the burner or cutting off the heating for a short time. For longer periods of shut down, close all valves and the oil supply stop-cock.

Clean the filter and nozzle by washing in petrol or paraffin.

Make sure the filter medium is not damaged or defective.

Protect electrical gear from damp.

Warning

Never stand too near or put your face to the inspection or fire door, when the burner is about to start.

Never use a naked flame to ignite oil if the electrical ignition fails.

Always wait for about 10 minutes for the unburnt gases to disperse before restarting the oil burner if it has failed to ignite previously.

Installed by:

.....

Tel:

